



Universidad de Oviedo

Pliego de Condiciones- Planos Eléctricos del Trabajo Fin de Máster  
realizado por

ESTEBAN GIANCARLO BACILIO LOO

para la obtención del título de

Máster en Ingeniería de Automatización e Informática Industrial

**AUTOMATIZACIÓN DE LÍNEAS DE  
PASTEURIZACIÓN, SIEMBRA Y CULTIVO DE  
FERMENTOS PARA LA FABRICACIÓN DE YOGURT  
FIRME**

JULIO DE 2015

# Índice

<b>ÍNDICE.....</b>	<b>0</b>
<b>ÍNDICE DE ILUSTRACIONES .....</b>	<b>2</b>
<b>1 INTRODUCCIÓN .....</b>	<b>3</b>
1.1 Identificación del proyecto.....	3
1.2 Descripción del documento .....	3
1.3 Ámbito del documento.....	3
1.4 Referencias.....	3
<b>2 DESCRIPCIÓN DE PLANOS ELECTRICOS.....</b>	<b>4</b>
<b>3 PLANOS ELÉCTRICOS .....</b>	<b>6</b>

# Índice de Ilustraciones

Ilustración 1: Vista de Estructura del Proyecto con Eplan Electric P8.....	5
--	---

# 1 INTRODUCCIÓN

## 1.1 Identificación del proyecto

Título: Automatización de Líneas de Pasteurización, Siembra y Cultivo de Fermentos para la Fabricación de Yogurt Firme.

Directores: Víctor Manuel González Suárez, Doctor Ingeniero Informático.

Autor: Esteban Giancarlo Bacilio Loo

Fecha: Junio de 2015

Financiación: Proyecto financiado por la empresa CAPSA FOOD.

## 1.2 Descripción del documento

El objetivo de este documento es suministrar información sobre el cableado y conexión de equipos de control y potencia involucrados en el desarrollo del proyecto. Otros detalles relacionados a la elaboración y estructura de los planos eléctricos pueden ser consultados en el documento “*Pliego de Condiciones*”

## 1.3 Ámbito del documento

Este documento “*Pliego de Condiciones-Planos Eléctricos*”, pertenece al trabajo final de master “***Automatización de Líneas de Pasteurización, Siembra y Cultivo de Fermentos para la Fabricación de Yogurt Firme***” cuyo autor es **Esteban Giancarlo Bacilio Loo**, alumno del Master en Automatización e Informática Industrial de la *Universidad de Oviedo- Campus Gijón*.

## 1.4 Referencias

Textos referenciados en este documento:

- No se hace referencia a ningún documento.

## 2 DESCRIPCIÓN DE PLANOS ELECTRICOS

La documentación correspondiente a los planos eléctricos del proyecto se encuentra estructurada por el software Eplan Electric P8 de la siguiente forma:

- **Carpeta Principal del Proyecto:** tiene el nombre de *PROYECTOYOGURT\_CAPSA*.
  
- **Carpeta Secundaria CA1:** Contiene la sección de documentos EAA que en este caso corresponden a la portada e índice de la documentación.
  
- **Carpeta Secundaria EB3:** Contiene tres secciones que se catalogan en:
  - **EBS:** Corresponde a la documentación de Equipos PLC y Tarjetas de Acondicionamiento 4-20 mA.
  
  - **ET1:** Corresponde a la documentación de Equipos de Potencia, Control, Sensores y cableado E/S a instalar en el Armario Principal o Estación Maestra del proyecto desarrollado.
  
  - **ET2:** Corresponde a la documentación de Equipos de Potencia, Control, Sensores y cableado E/S a instalar en el Armario Secundario o Estación Remota del proyecto desarrollado.
  
- **Carpeta Secundaria EB3: Contiene tres secciones que se catalogan en:**
  - **RPC:** Corresponde a la documentación de conexión de borneras de proyecto desarrollado.
  
  - **PART\_STKL:** Corresponde al listado de equipos utilizados en el diseño de los planos eléctricos.

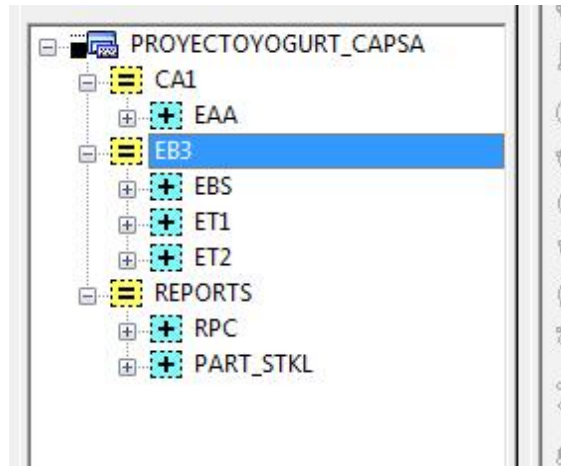

**Ilustración 1: Vista de Estructura del Proyecto con Eplan Electric P8**

Todos los equipos y cableado utilizado en el diseño de los planos eléctricos en Eplan Electric P8 representan una propuesta que puede ser consultada en este trabajo y que se trata de una propuesta basada en los requerimientos y especificaciones de diseño desarrollados para la implementación y puesta en marcha de este proyecto.

### **3 PLANOS ELÉCTRICOS**

A continuación se muestra la documentación generada luego de realizar el diseño en Eplan Electric P8 para este proyecto en específico. Al tratarse de una propuesta, se requiere una revisión de los mismos por parte del personal técnico cualificado en caso de ser utilizados para la implementación del proyecto. Se entrega a disposición de la empresa CAPSA Food, los ficheros generados por el software en caso que se requiera cualquier corrección, modificación o ampliación del proyecto presentado.





# Table of contents

Column X: An automatically generated page was edited

F06\_001

Page	Page description	Supplementary page field	Date	Edited by	X
=CA1+EAA/1	Title page		06/06/2015	Esteban	X
=CA1+EAA/2	Indice de páginas : =CA1+EAA/1 - =EB3+ET1/17				
=CA1+EAA/3	Indice de páginas : =EB3+ET1/18 - =EB3+ET2/22				
=CA1+EAA/4	Indice de páginas : =EB3+ET2/23 - =REPORTS+RPC/27				
=CA1+EAA/5	Indice de páginas : =REPORTS+RPC/28 - =REPORTS+PART_STKL/4				
=EB3+EBS/1	ESTACION MAESTRA (1)		07/06/2015	Esteban	X
=EB3+EBS/2	ESTACION MAESTRA (2)		07/06/2015	Esteban	X
=EB3+EBS/3	ESTACION MAESTRA (3)		07/06/2015	Esteban	X
=EB3+EBS/4	ESTACION MAESTRA-TRANSMISORES (1)		07/06/2015	Esteban	X
=EB3+EBS/5	ESTACION MAESTRA-TRANSMISORES (2)		07/06/2015	Esteban	X
=EB3+EBS/6	ESTACION MAESTRA- TRANSMISORES (3)		07/06/2015	Esteban	X
=EB3+EBS/7	ESTACION REMOTA (1)		07/06/2015	Esteban	X
=EB3+EBS/8	ESTACION REMOTA (2)		07/06/2015	Esteban	X
=EB3+EBS/9	ESTACION REMOTA (3)		07/06/2015	Esteban	X
=EB3+EBS/10	ESTACION REMOTA- TRANSMISORES (1)		07/06/2015	Esteban	X
=EB3+EBS/11	ESTACION REMOTA- TRANSMISORES (2)		07/06/2015	Esteban	X
=EB3+ET1/1	Linea de Suministro Estacion Maestra		07/06/2015	Esteban	
=EB3+ET1/2	Linea de Suministro-Estacion Remota		07/06/2015	Esteban	
=EB3+ET1/3	Bombas y Motores Pasteurizadores		07/06/2015	Esteban	
=EB3+ET1/4	Bombas y Motores Pasteurizadores		08/01/2015	DELL	
=EB3+ET1/5	Bombas y Motores ERCAS y Fermentos		06/06/2015	Esteban	
=EB3+ET1/6	Bombas y Motores ERCAS y Fermentos		08/01/2015	DELL	
=EB3+ET1/7	Bombas y Motores ERCAS y Fermentos		08/01/2015	DELL	
=EB3+ET1/8	Preaccionadores de Equipos de Potencia		07/06/2015	Esteban	
=EB3+ET1/9	Preaccionadores de Equipos de Potencia		08/01/2015	DELL	
=EB3+ET1/10	Preaccionadores de Equipos de Potencia		07/06/2015	Esteban	
=EB3+ET1/11	Preaccionadores de Equipos de Potencia		07/06/2015	Esteban	
=EB3+ET1/12	Modulo Principal		07/06/2015	Esteban	
=EB3+ET1/13	Entradas Analog.CPU S7-300		07/06/2015	Esteban	
=EB3+ET1/14	Entradas Analog.CPU S7-300		07/06/2015	Esteban	
=EB3+ET1/15	Salidas Analog.CPU S7-300		07/06/2015	Esteban	
=EB3+ET1/16	Salidas Analog.CPU S7-300		07/06/2015	Esteban	
=EB3+ET1/17	Salidas Analog.CPU S7-300		07/06/2015	Esteban	

			Date	14/06/2015	Esteban Bacilio	CAPSA FOOD- CENTRAL LECHERA ASTURIANA	Indice de páginas : =CA1+EAA/1 - =EB3+ET1/17	= CA1 + EAA	Page	2
			Ed.	Esteban					Page	132
Modification	Date	Name	Original		Replaced by	Replaced by		Estandar IEC- 61346		

# Table of contents

Column X: An automatically generated page was edited

F06\_001

Page	Page description	Supplementary page field	Date	Edited by	X
=EB3+ET1/18	Salidas Analog.CPU S7-300		07/06/2015	Esteban	
=EB3+ET1/19	Entradas Digitales Modulo (A3) S7-300		07/06/2015	Esteban	
=EB3+ET1/20	Entradas Digitales Modulo (A3) S7-300		07/06/2015	Esteban	
=EB3+ET1/21	Entradas Digitales Modulo (A3) S7-300		07/06/2015	Esteban	
=EB3+ET1/22	Entradas Digitales Modulo (A3) S7-300		07/06/2015	Esteban	
=EB3+ET1/23	Entradas Digitales Modulo A4		07/06/2015	Esteban	
=EB3+ET1/24	Entradas Digitales Modulo A4		07/06/2015	Esteban	
=EB3+ET1/25	Salidas Digitales Modulo (A5) ET200M		07/06/2015	Esteban	
=EB3+ET1/26	Salidas Digitales Modulo (A5) ET200M		07/06/2015	Esteban	
=EB3+ET1/27	Salidas Digitales Modulo (A5) ET200M		07/06/2015	Esteban	
=EB3+ET1/28	Salidas Digitales Modulo (A5) ET200M		07/06/2015	Esteban	
=EB3+ET2/1	Potencia Estacion Remota		07/06/2015	Esteban	
=EB3+ET2/2	Preaccionadores de Equipos de Potencia		07/06/2015	Esteban	
=EB3+ET2/3	Preaccionadores de Equipos de Potencia		07/06/2015	Esteban	
=EB3+ET2/4	Preaccionadores de Equipos de Potencia		07/06/2015	Esteban	
=EB3+ET2/5	Preaccionadores de Equipos de Potencia		07/06/2015	Esteban	
=EB3+ET2/6	Modulo Remoto Siemens ET200M		07/06/2015	Esteban	
=EB3+ET2/7	Entradas Analog. Modulo ET200M		07/06/2015	Esteban	
=EB3+ET2/8	Entrada Analog. Modulo ET200M		07/06/2015	Esteban	
=EB3+ET2/9	Entradas Digitales (B2) Modulo ET200M		07/06/2015	Esteban	
=EB3+ET2/10	Entradas Digitales (B2) Modulo ET200M		07/06/2015	Esteban	
=EB3+ET2/11	Entradas Digitales (B2) Modulo ET200M		07/06/2015	Esteban	
=EB3+ET2/12	Entradas Digitales (B2) Modulo ET200M		07/06/2015	Esteban	
=EB3+ET2/13	Entradas Digitales Modulo (B3) ET200M		07/06/2015	Esteban	
=EB3+ET2/14	Entradas Digitales Modulo (B3) ET200M		07/06/2015	Esteban	
=EB3+ET2/15	Entradas Digitales Modulo (B3) ET200M		07/06/2015	Esteban	
=EB3+ET2/16	Entradas Digitales Modulo (B3) ET200M		07/06/2015	Esteban	
=EB3+ET2/17	Entradas Digitales Modulo (B4) ET200M		07/06/2015	Esteban	
=EB3+ET2/18	Entradas Digitales Modulo (B4) ET200M		07/06/2015	Esteban	
=EB3+ET2/19	Entradas Digitales Modulo (B4) ET200M		07/06/2015	Esteban	
=EB3+ET2/20	Entradas Digitales Modulo (B4) ET200M		07/06/2015	Esteban	
=EB3+ET2/21	Salidas Digitales Modulo (B5) ET200M		07/06/2015	Esteban	
=EB3+ET2/22	Salidas Digitales Modulo (B5) ET200M		07/06/2015	Esteban	

Date	14/06/2015	Esteban Bacilio	CAPSA FOOD- CENTRAL LECHERA ASTURIANA	Indice de páginas : =EB3+ET1/18 - =EB3+ET2/22	= CA1
Ed.	Esteban		DE YOGURT - TFM		+ EAA
Appr		AUTOMATIZACIÓN DE LINEAS DE PRODUCCIÓN			
Modification	Date	Name	Original	Replaced by	Replaced by
					Estandar IEC- 61346
					Page 3
					Page 132

# Table of contents

Column X: An automatically generated page was edited

F06\_001

Page	Page description	Supplementary page field	Date	Edited by	X
=EB3+ET2/23	Salidas Digitales Modulo (B5) ET200M		07/06/2015	Esteban	
=EB3+ET2/24	Salidas Digitales Modulo (B5) ET200M		07/06/2015	Esteban	
=EB3+ET2/28	Salidas Digitales Modulo (B6) ET200M		07/06/2015	Esteban	
=EB3+ET2/29	Salidas Digitales Modulo (B6) ET200M		07/06/2015	Esteban	
=EB3+ET2/30	Salidas Digitales Modulo (B6) ET200M		07/06/2015	Esteban	
=EB3+ET2/31	Salidas Digitales Modulo (B6) ET200M		07/06/2015	Esteban	
=REPORTS+RPC/1	Plano de conexiones de bornes =EB3+ET1-IP1				
=REPORTS+RPC/2	Plano de conexiones de bornes =EB3+ET1-IP2				
=REPORTS+RPC/3	Plano de conexiones de bornes =EB3+ET1-IP3				
=REPORTS+RPC/4	Plano de conexiones de bornes =EB3+ET1-IP4				
=REPORTS+RPC/5	Plano de conexiones de bornes =EB3+ET1-IP5				
=REPORTS+RPC/6	Plano de conexiones de bornes =EB3+ET1-IP6				
=REPORTS+RPC/7	Plano de conexiones de bornes =EB3+ET1-TP1				
=REPORTS+RPC/8	Plano de conexiones de bornes =EB3+ET1-TP2				
=REPORTS+RPC/9	Plano de conexiones de bornes =EB3+ET1-W2				
=REPORTS+RPC/10	Plano de conexiones de bornes =EB3+ET1-X0				
=REPORTS+RPC/11	Plano de conexiones de bornes =EB3+ET1-X1				
=REPORTS+RPC/12	Plano de conexiones de bornes =EB3+ET1-X2				
=REPORTS+RPC/13	Plano de conexiones de bornes =EB3+ET1-X5				
=REPORTS+RPC/14	Plano de conexiones de bornes =EB3+ET1-X6				
=REPORTS+RPC/15	Plano de conexiones de bornes =EB3+ET1-X7				
=REPORTS+RPC/16	Plano de conexiones de bornes =EB3+ET1-X7				
=REPORTS+RPC/17	Plano de conexiones de bornes =EB3+ET1-X7				
=REPORTS+RPC/18	Plano de conexiones de bornes =EB3+ET1-X7				
=REPORTS+RPC/19	Plano de conexiones de bornes =EB3+ET1-X7				
=REPORTS+RPC/20	Plano de conexiones de bornes =EB3+ET1-X8				
=REPORTS+RPC/21	Plano de conexiones de bornes =EB3+ET1-X8				
=REPORTS+RPC/22	Plano de conexiones de bornes =EB3+ET1-X8				
=REPORTS+RPC/23	Plano de conexiones de bornes =EB3+ET1-X8				
=REPORTS+RPC/24	Plano de conexiones de bornes =EB3+ET2-X1				
=REPORTS+RPC/25	Plano de conexiones de bornes =EB3+ET2-X5				
=REPORTS+RPC/26	Plano de conexiones de bornes =EB3+ET2-X11				
=REPORTS+RPC/27	Plano de conexiones de bornes =EB3+ET2-X15				

Date	14/06/2015	Esteban Bacilio	CAPSA FOOD- CENTRAL LECHERA ASTURIANA	Indice de páginas : =EB3+ET2/23 - =REPORTS+RPC/27	= CA1 + EAA
Ed.	Esteban				
Appr		AUTOMATIZACIÓN DE LINEAS DE PRODUCCIÓN DE YOGURT - TFM			
Modification	Date	Name	Original	Replaced by	Replaced by
					Estandar IEC- 61346
					Page 4
					Page 132

# Table of contents

Column X: An automatically generated page was edited

F06\_001

Page	Page description	Supplementary page field	Date	Edited by	X
=REPORTS+RPC/28	Plano de conexiones de bornes =EB3+ET2-X15				
=REPORTS+RPC/29	Plano de conexiones de bornes =EB3+ET2-X17				
=REPORTS+RPC/30	Plano de conexiones de bornes =EB3+ET2-X17				
=REPORTS+RPC/31	Plano de conexiones de bornes =EB3+ET2-X17				
=REPORTS+RPC/32	Plano de conexiones de bornes =EB3+ET2-X17				
=REPORTS+RPC/33	Plano de conexiones de bornes =EB3+ET2-X17				
=REPORTS+RPC/34	Plano de conexiones de bornes =EB3+ET2-X17				
=REPORTS+RPC/35	Plano de conexiones de bornes =EB3+ET2-X17				
=REPORTS+RPC/36	Plano de conexiones de bornes =EB3+ET2-X17				
=REPORTS+RPC/37	Plano de conexiones de bornes =EB3+ET2-X17				
=REPORTS+RPC/38	Plano de conexiones de bornes =EB3+ET2-X17				
=REPORTS+RPC/39	Plano de conexiones de bornes =EB3+ET2-X17				
=REPORTS+RPC/40	Plano de conexiones de bornes =EB3+ET2-X17				
=REPORTS+RPC/41	Plano de conexiones de bornes =EB3+ET2-X18				
=REPORTS+RPC/42	Plano de conexiones de bornes =EB3+ET2-X18				
=REPORTS+RPC/43	Plano de conexiones de bornes =EB3+ET2-X18				
=REPORTS+RPC/44	Plano de conexiones de bornes =EB3+ET2-X18				
=REPORTS+RPC/45	Plano de conexiones de bornes =EB3+ET2-X18				
=REPORTS+RPC/46	Plano de conexiones de bornes =EB3+ET2-X18				
=REPORTS+RPC/47	Plano de conexiones de bornes =EB3+ET2-X18				
=REPORTS+RPC/48	Plano de conexiones de bornes =EB3+ET2-X18				
=REPORTS+PART_STKL/3	Parts list : PXC.2810337 - SEW.DV112M4				
=REPORTS+PART_STKL/4	Parts list : SEW.DV112M4 - PHO.3046456				

# ESTACION MAESTRA

## PASTEURIZADO, SIEMBRA Y FERMENTOS

+ET1-A0  
+ET1/12.1  
Rack Y  
Slot 0  
SIE.6ES7315-2EH14-0AB0

S7-300  
CPU 315-2 PN/DP

SIEMENS

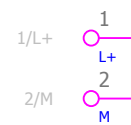

6ES7315-2EH14-0AB0

+ET1-A1  
+ET1/13.1  
+ET1/14.1  
Rack X  
Slot 1  
SIE.6ES7331-7KF02-0AB0

S7-300  
SM 331 AI 8 x 12 BIT

SIEMENS

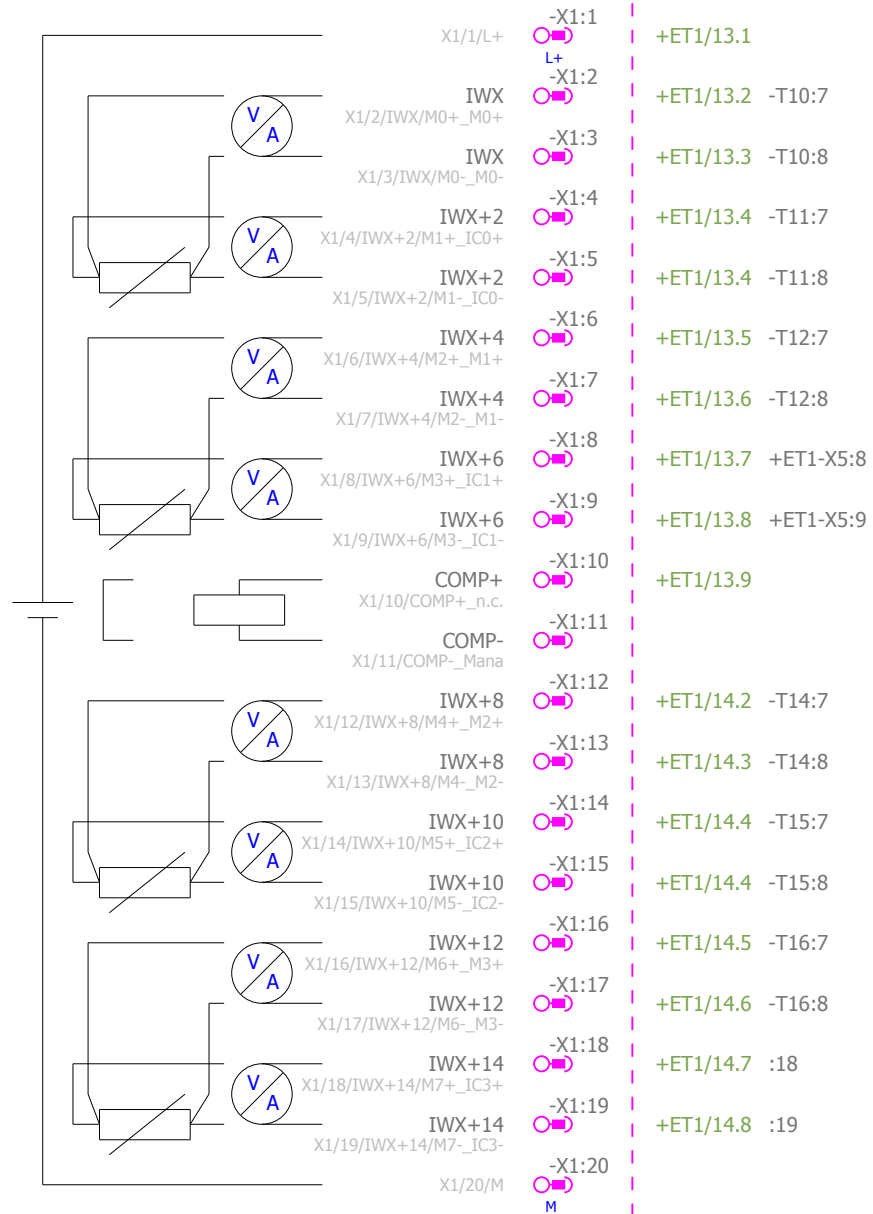

6ES7331-7KF02-0AB0

Date	07/06/2015	Esteban Bacilio	CAPSA FOOD- CENTRAL LECHERA ASTURIANA DE YOGURT - TFM	ESTACION MAESTRA (1)	= EB3
Ed.	Esteban				+ EBS
Appr		AUTOMATIZACIÓN DE LINEAS DE PRODUCCIÓN			
Modification	Date	Name	Original	Replaced by	Replaced by
					Estandar IEC- 61346
					Page 1
					Page 132

+ET1-A2  
 +ET1/15.0  
 +ET1/16.0  
 +ET1/17.0  
 +ET1/18.0  
 Rack X  
 Slot Y  
 SIE.6ES7332-5HF00-0AB0

S7-300  
 SM 332 AO 8 x 12 BIT

SIEMENS

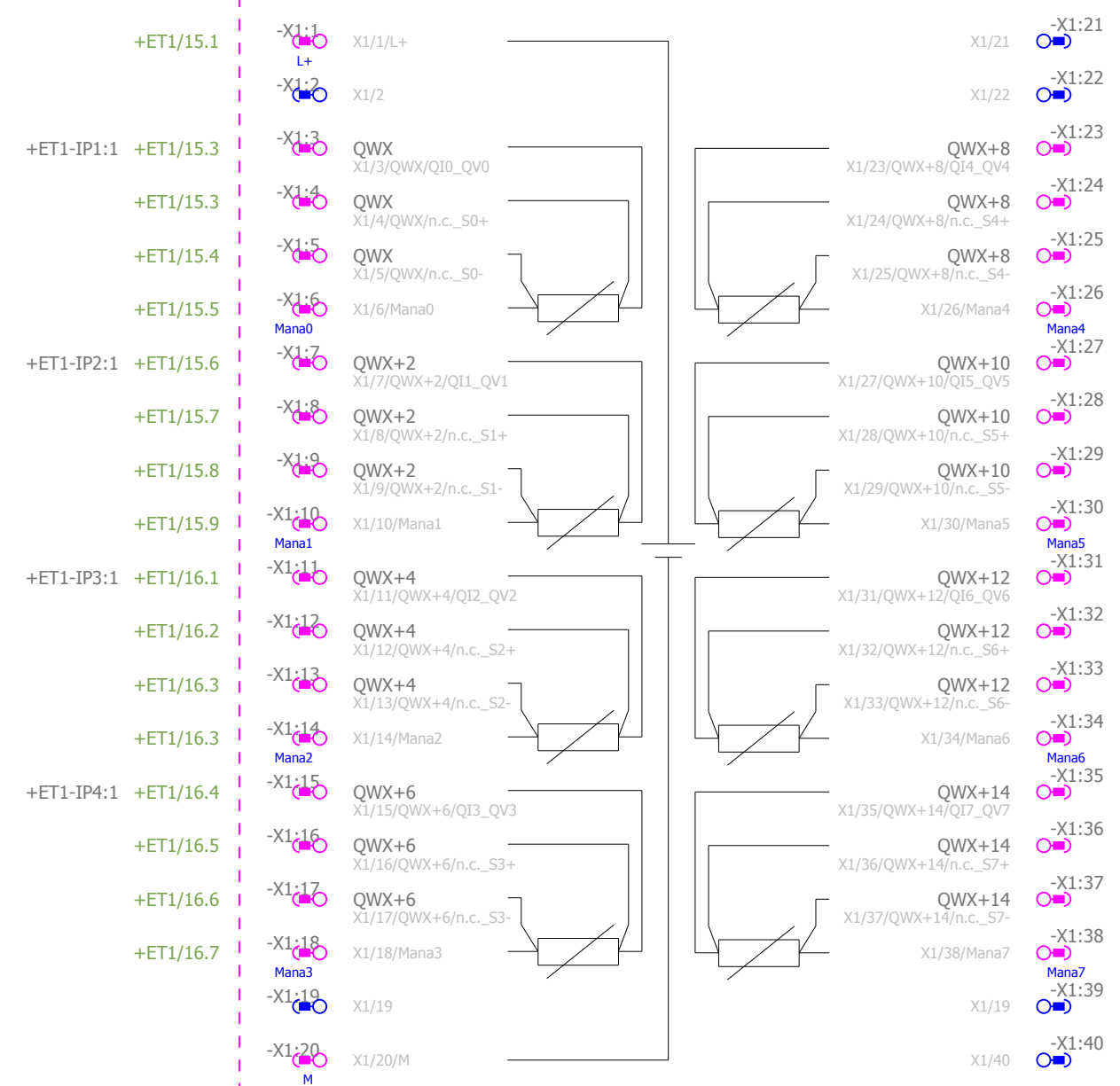

6ES7332-5HF00-0AB0

+ET1-A3  
 +ET1/19.0  
 +ET1/20.0  
 +ET1/21.0  
 +ET1/22.0  
 Rack Y  
 Slot 03  
 SIE.6ES7321-1BL00-0AA0

S7-300  
 SM 321 DI 32 x DC24V

SIEMENS

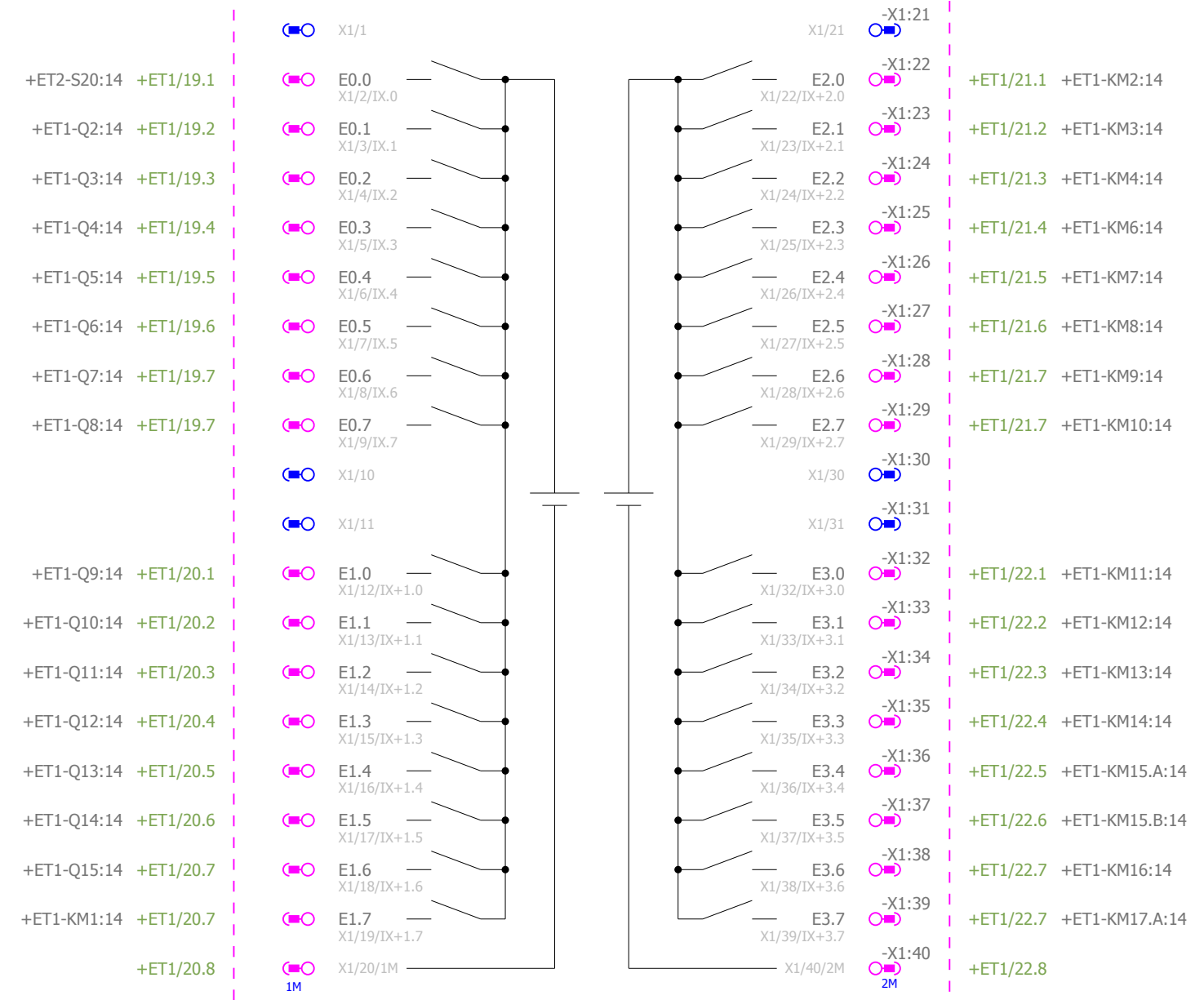

6ES7321-1BL00-0AA0

# ESTACION MAESTRA

## PASTEURIZADO, SIEMBRA Y FERMENTOS

1		3	
Date	07/06/2015	Esteban Bacilio	CAPSA FOOD- CENTRAL LECHERA ASTURIANA DE YOGURT - TFM
Ed.	Esteban	ESTACION MAESTRA (2)	
Appr		= EB3 + EBS	
Modification	Date	Name	Original
		Replaced by	Replaced by
		Estandar IEC- 61346	
		Page	2
		Page	132

+ET1-A4  
 +ET1/23.0  
 +ET1/24.0  
 Rack X  
 Slot Y  
 SIE.6ES7321-1BH02-0AA0

S7-300  
 SM 321 DI 16 x DC24V

SIEMENS

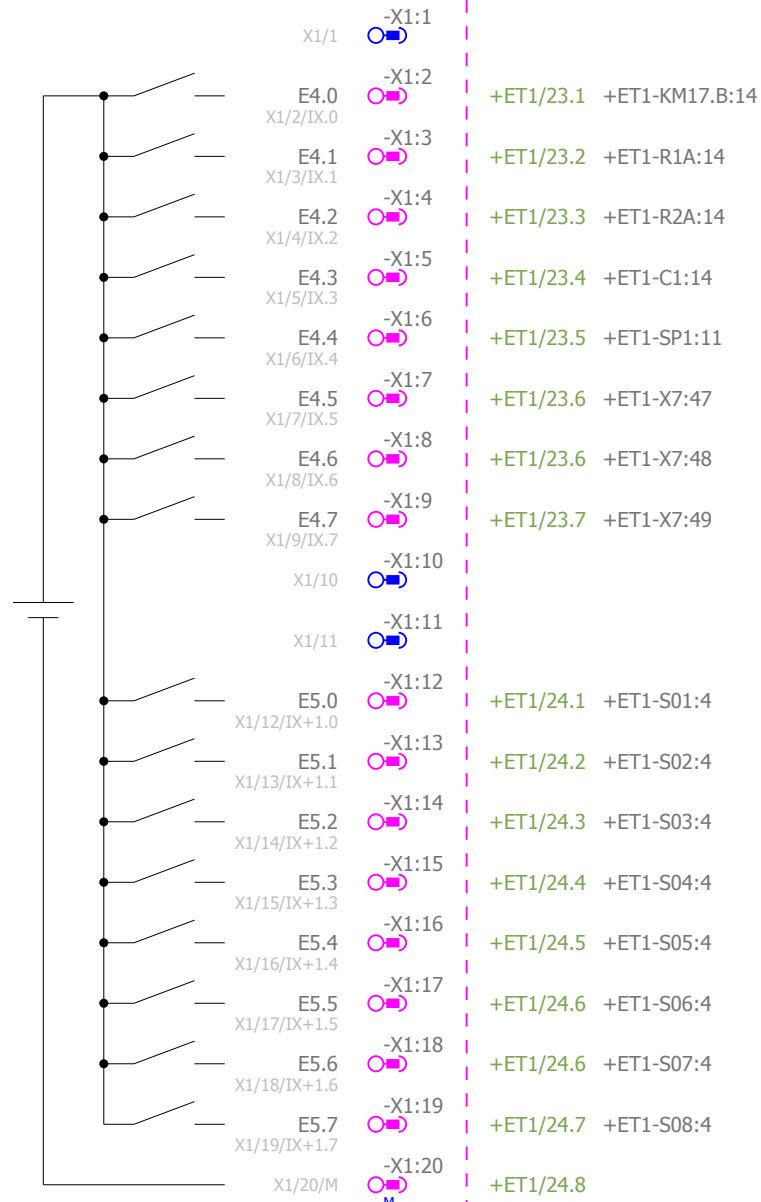

6ES7321-1BH02-0AA0

+ET1-A5  
 +ET1/25.0  
 +ET1/26.0  
 +ET1/27.0  
 +ET1/28.0  
 Rack X  
 Slot Y  
 SIE.6ES7322-1BL00-0AA0

S7-300  
 SM 322 DO 32 x DC24V/0,5A

SIEMENS

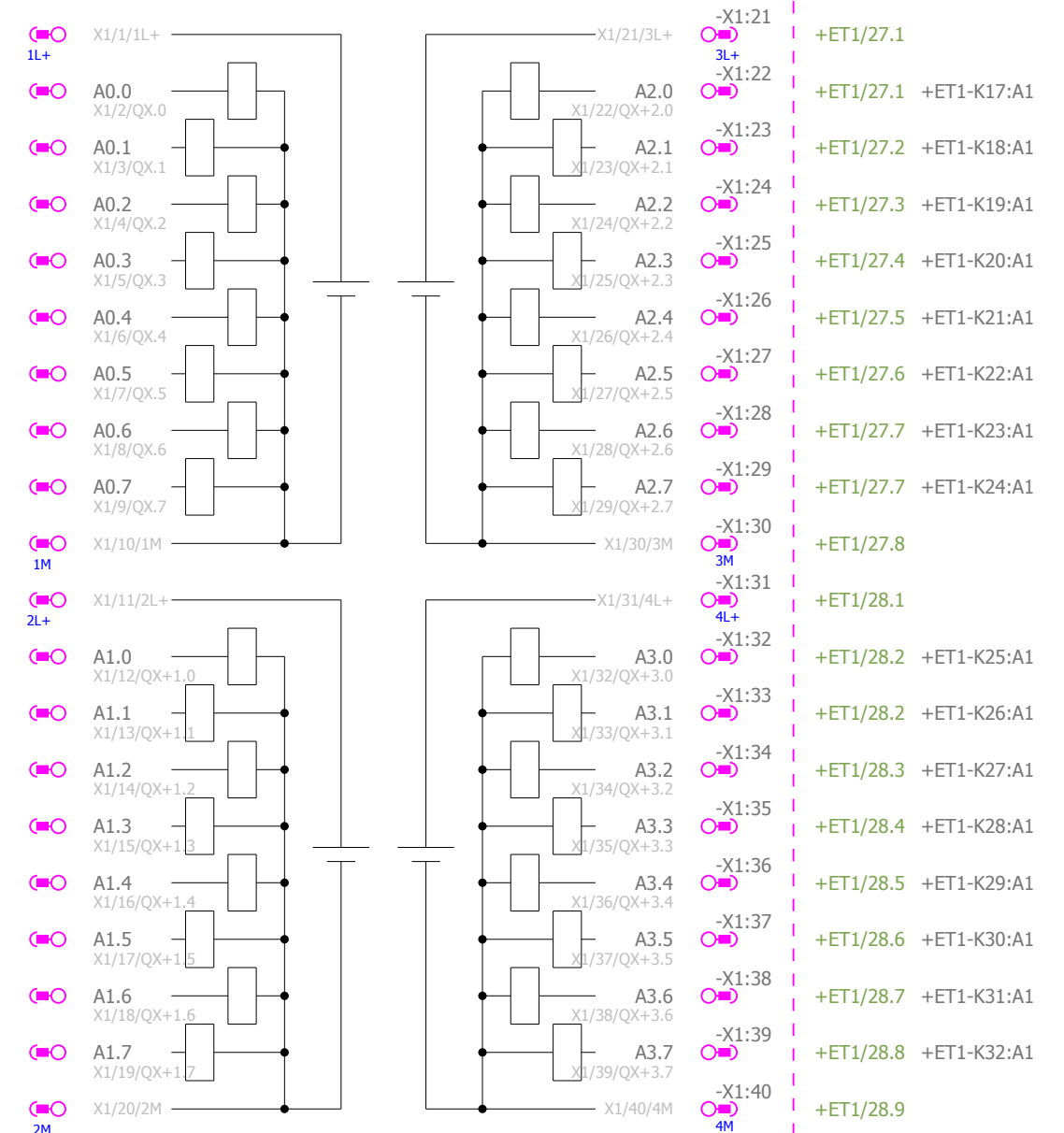

6ES7322-1BL00-0AA0

# ESTACION MAESTRA

## PASTEURIZADO, SIEMBRA Y FERMENTOS

Date	07/06/2015	Esteban Bacilio	CAPSA FOOD- CENTRAL LECHERA ASTURIANA DE YOGURT - TFM	ESTACION MAESTRA (3)	= EB3
Ed.	Esteban				+ EBS
Appr		AUTOMATIZACIÓN DE LINEAS DE PRODUCCIÓN DE YOGURT - TFM			
Modification	Date	Name	Original	Replaced by	Replaced by
					Estándar IEC- 61346
					Page 3
					Page 132

# ESTACION MAESTRA

## PASTEURIZADO, SIEMBRA Y FERMENTOS

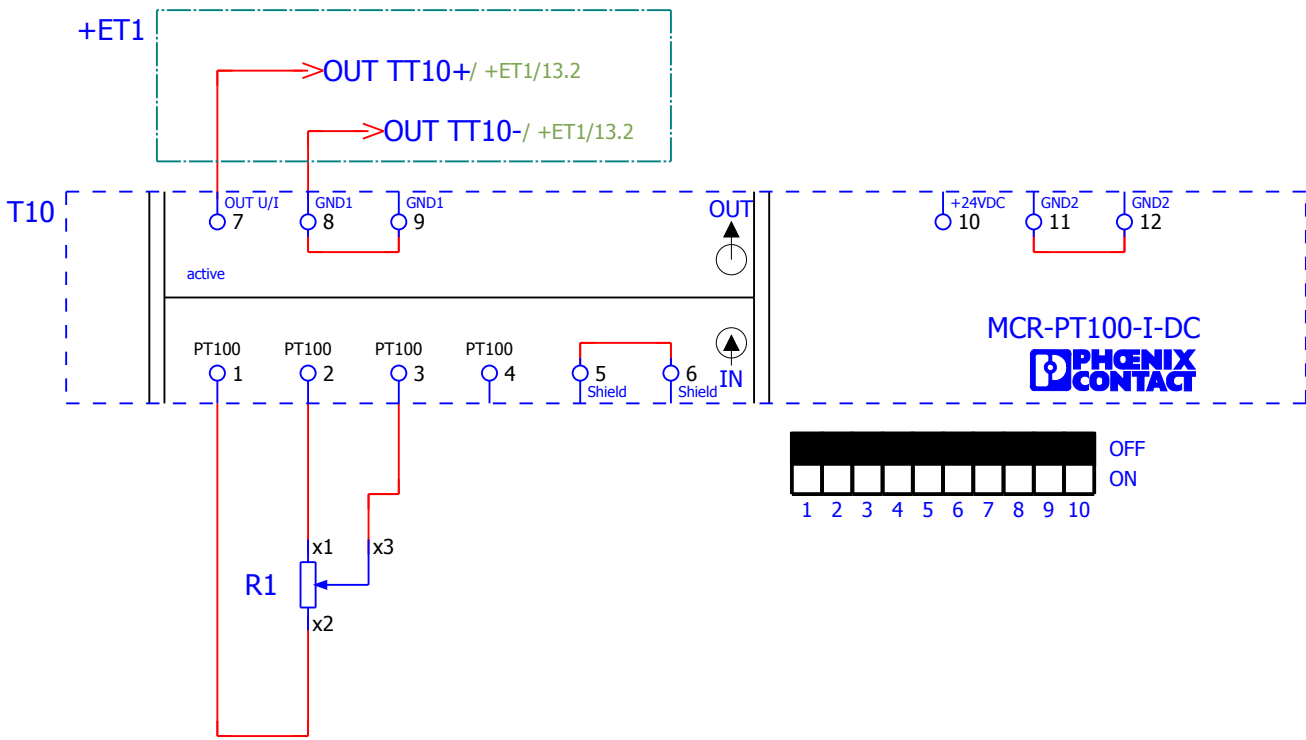

TRANSMISOR TEMPERATURA SALIDA DEL INTERCAMBIADOR PASTO1

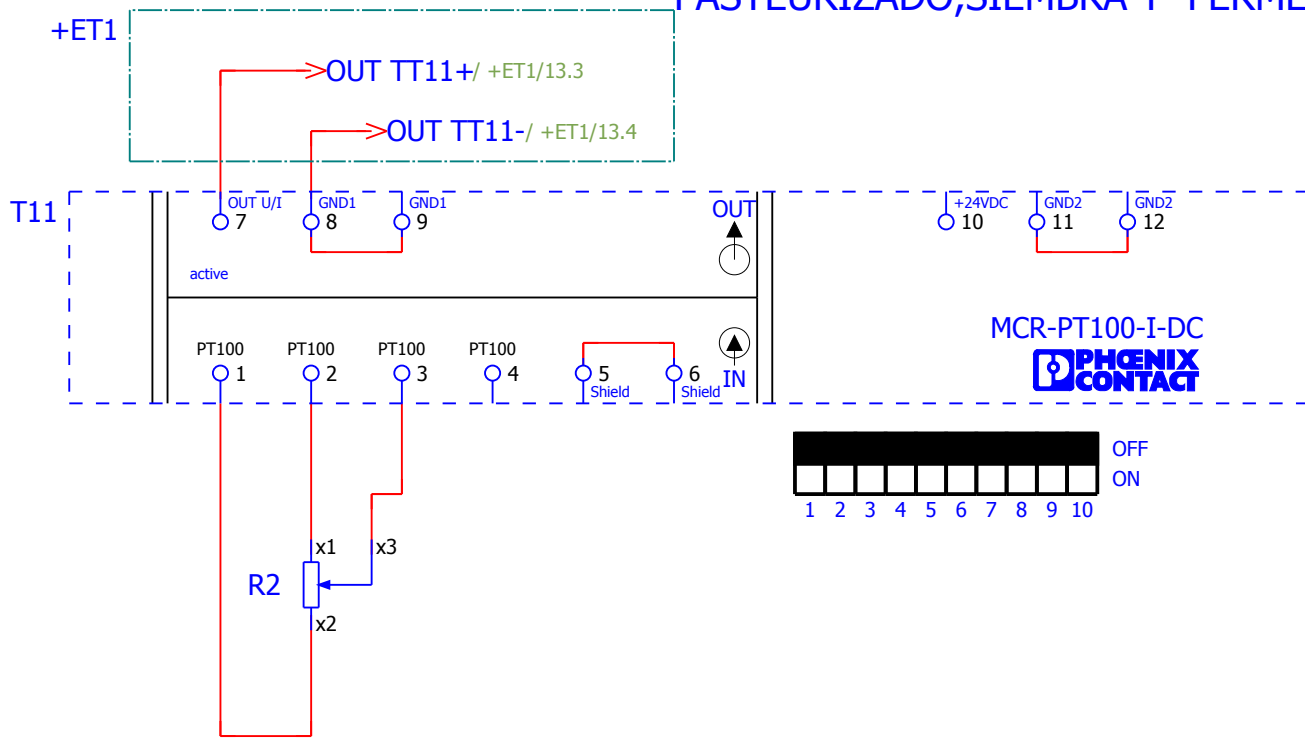

TRANSMISOR TEMPERATURA AGUA CALIENTE PASTO1

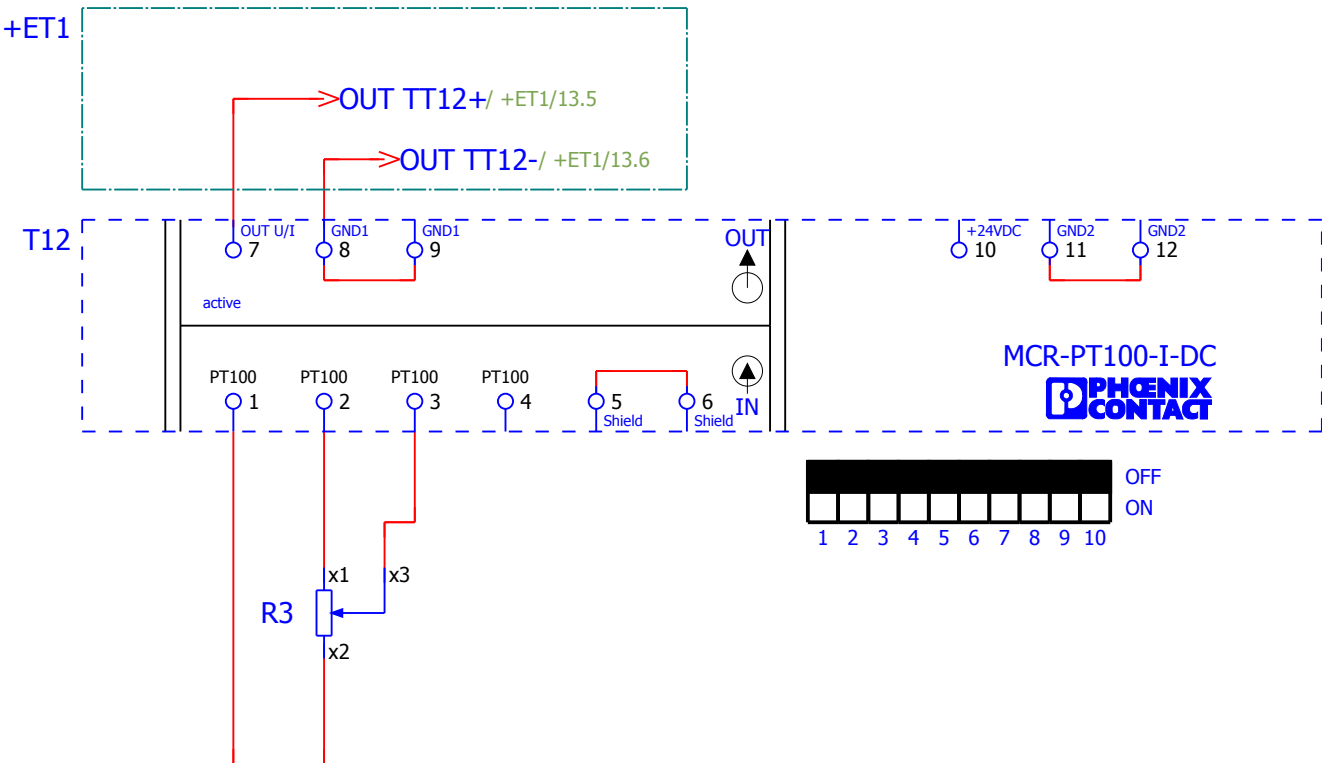

TRANSMISOR TEMPERATURA TUBO MANTENIMIENTO PASTO1

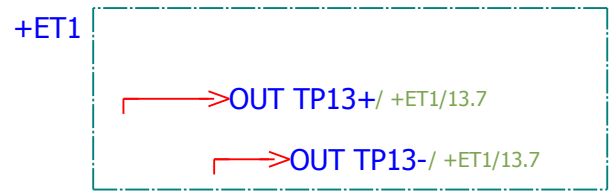

TRANSMISOR PRESION HOMOGENIZADOR PASTO 1



# ESTACION MAESTRA

## PASTEURIZADO, SIEMBRA Y FERMENTOS

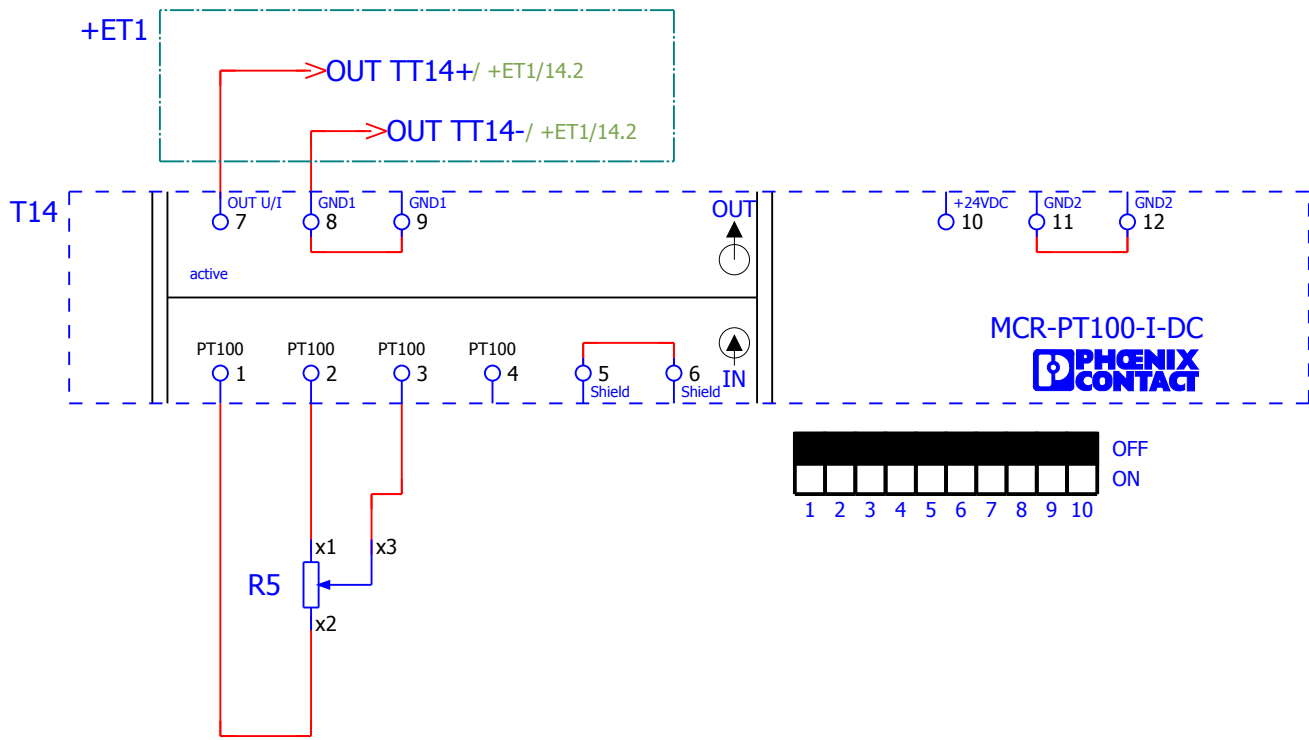

TRANSMISOR TEMPERATURA SALIDA DEL INTERCAMBIADOR/ENFRIADOR PASTO2

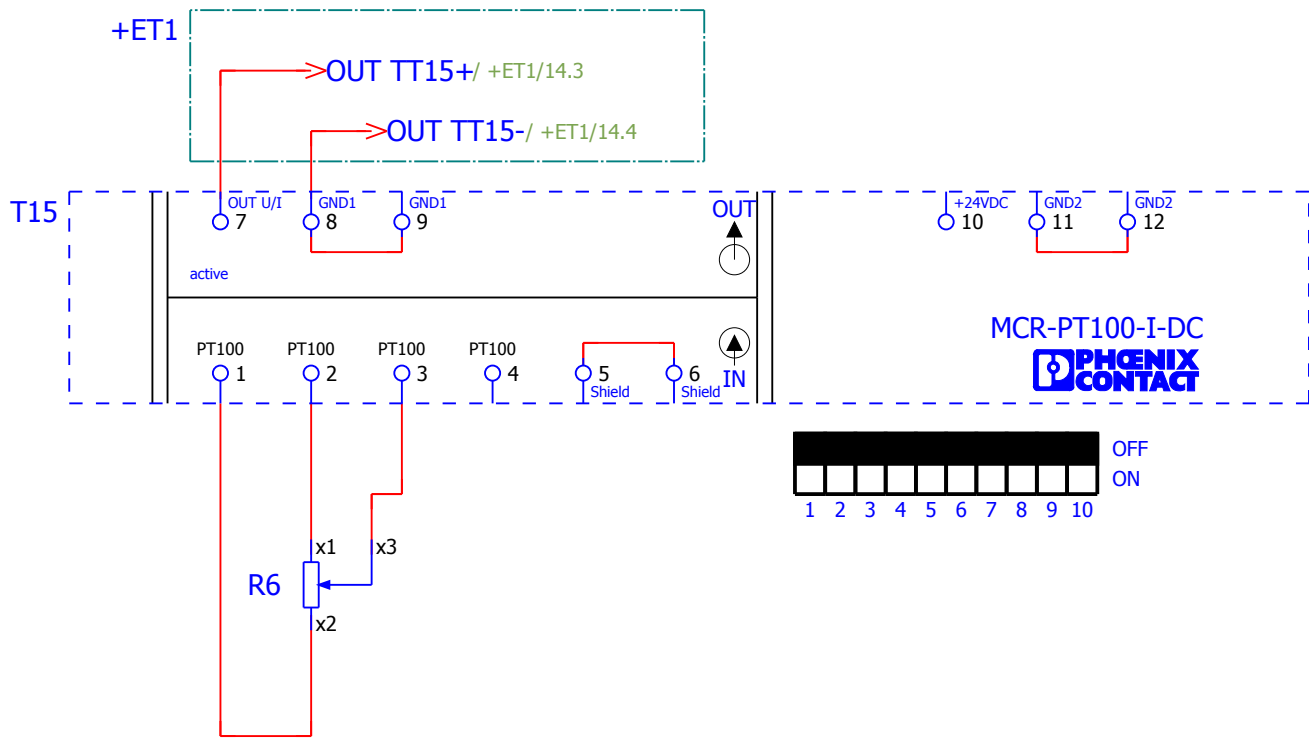

TRANSMISOR TEMPERATURA AGUA CALIENTE PASTO2

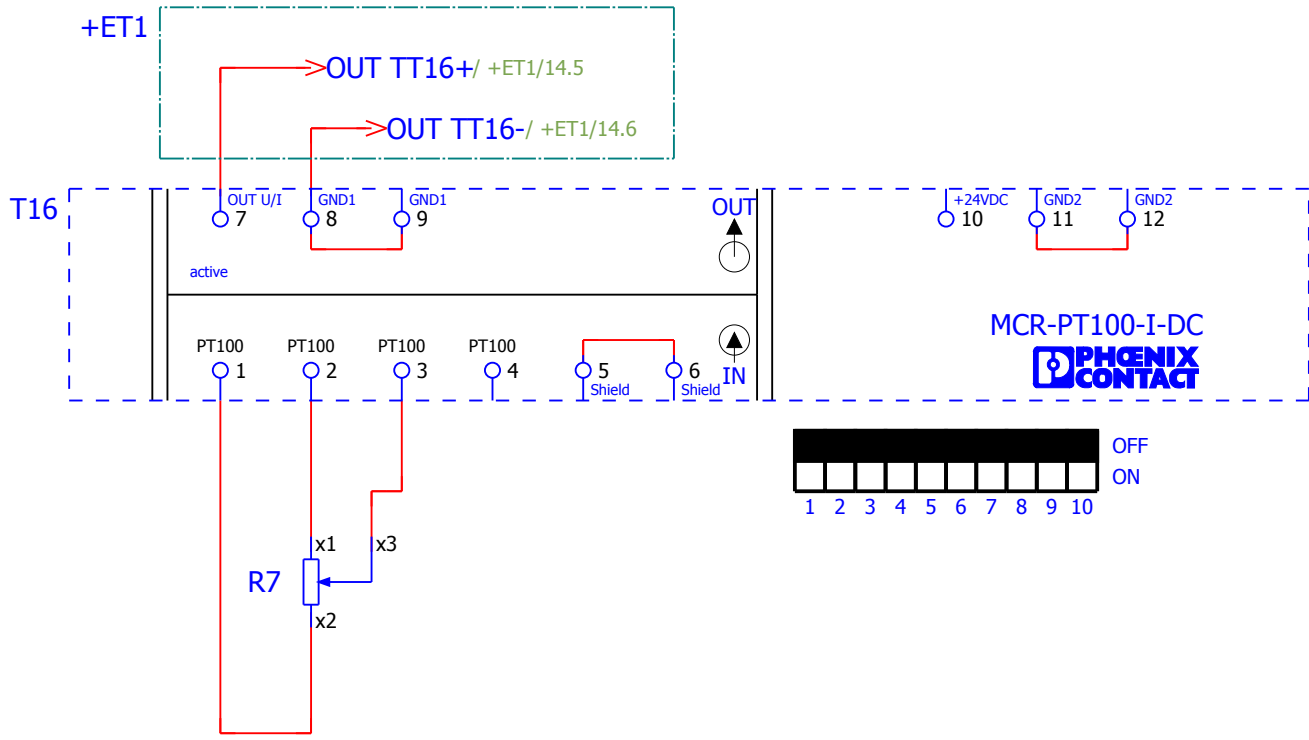

TRANSMISOR TEMPERATURA TUBO MANTENIMIENTO PASTO2

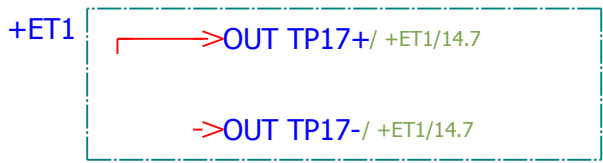

TRANSMISOR PRESION HOMOGENIZADOR PASTO 2



# ESTACION REMOTA

## SIEMBRA Y FERMENTOS

**+ET2-B0**  
 +ET2/6.2  
 CPU 315-2 DP  
 input 24VDC  
 Rack Y  
 Slot 00  
 SIE.6ES7153-1AA03-0XB0

**+ET2-B1**  
 /7.4  
 Rack Y  
 Slot 01

**+ET2-B2**  
 +ET2/9.0  
 +ET2/10.0  
 +ET2/11.0  
 +ET2/12.0  
 Rack Y  
 Slot 02  
 SIE.6ES7321-1BL00-0AA0

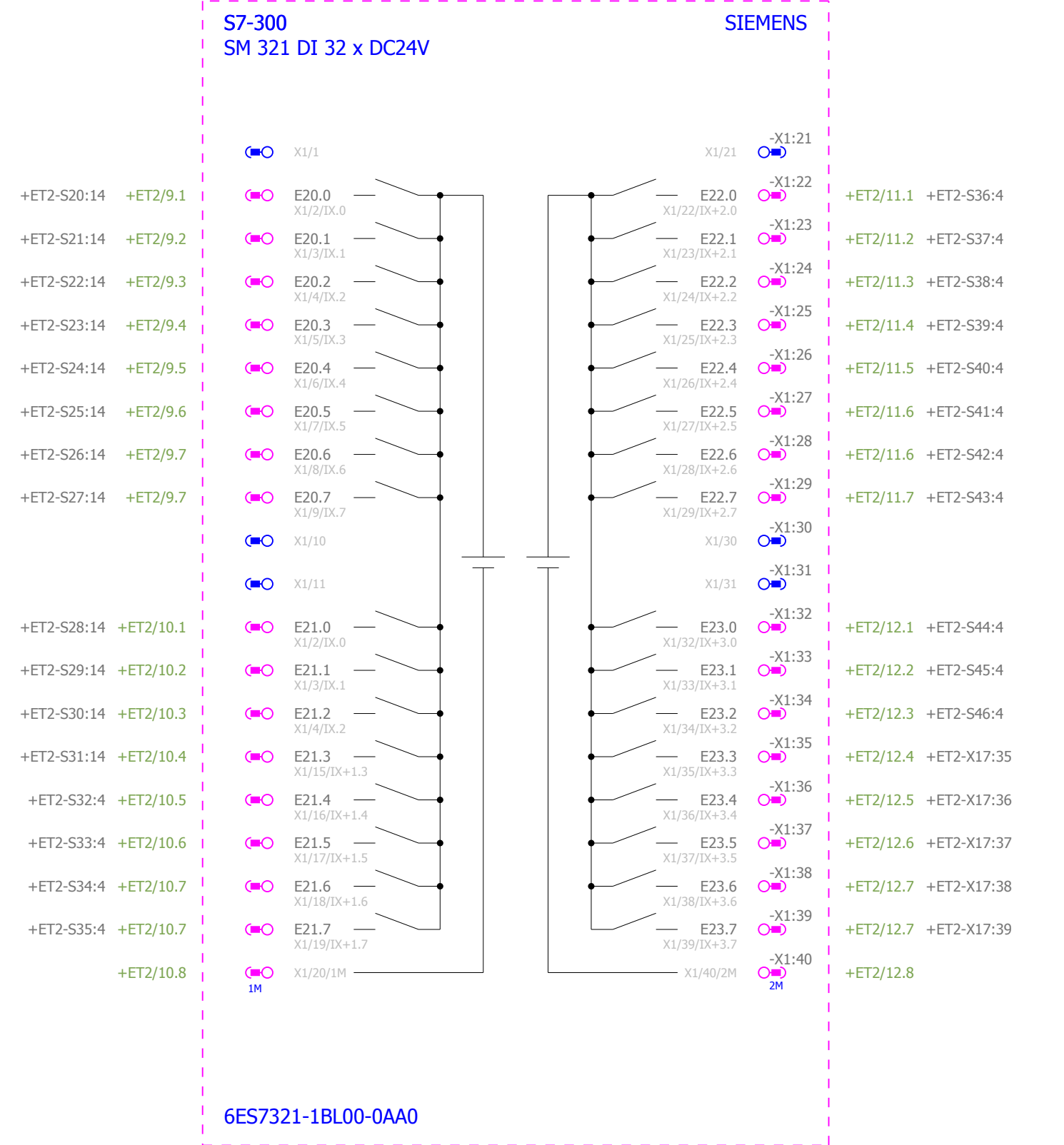
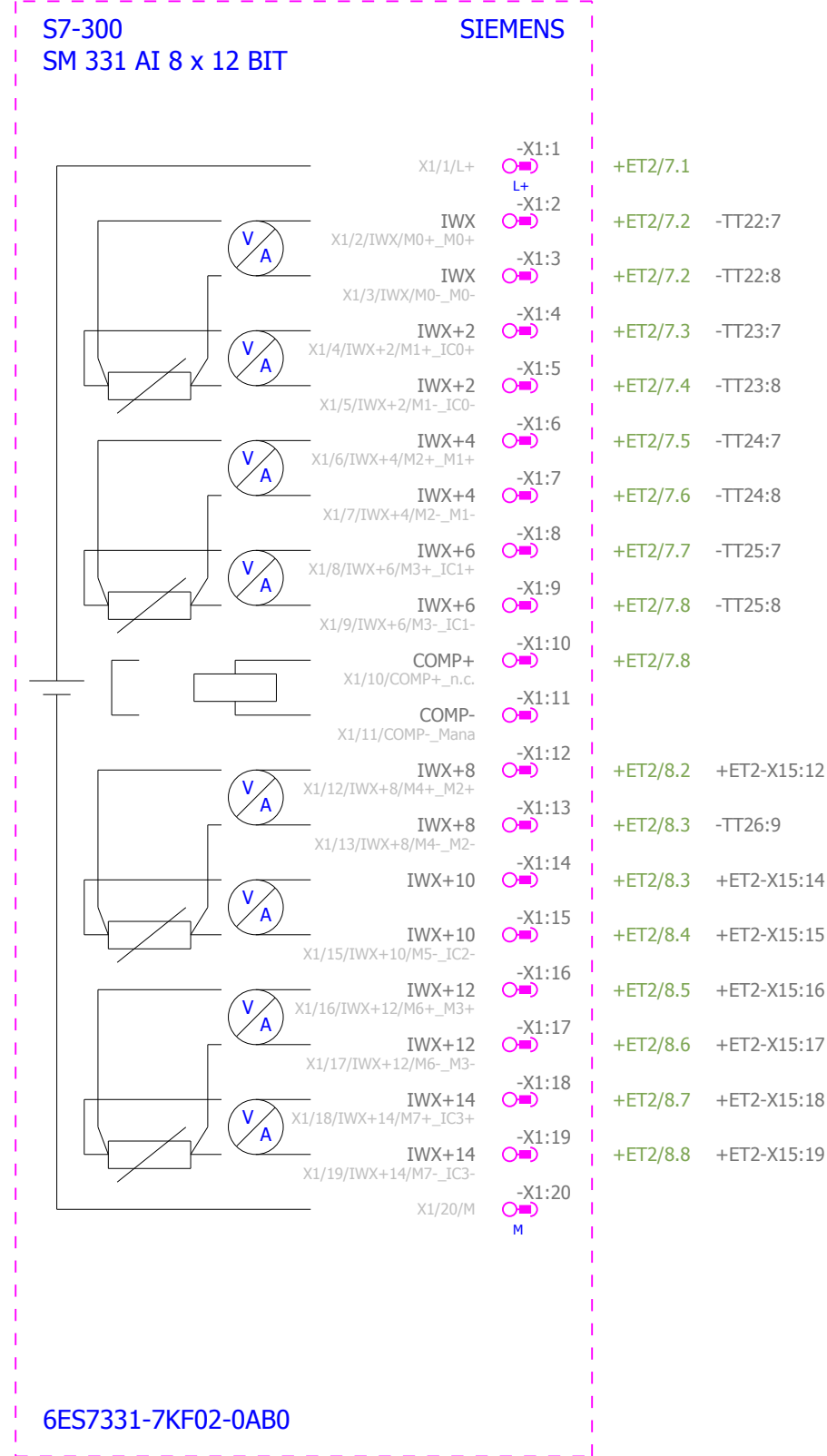
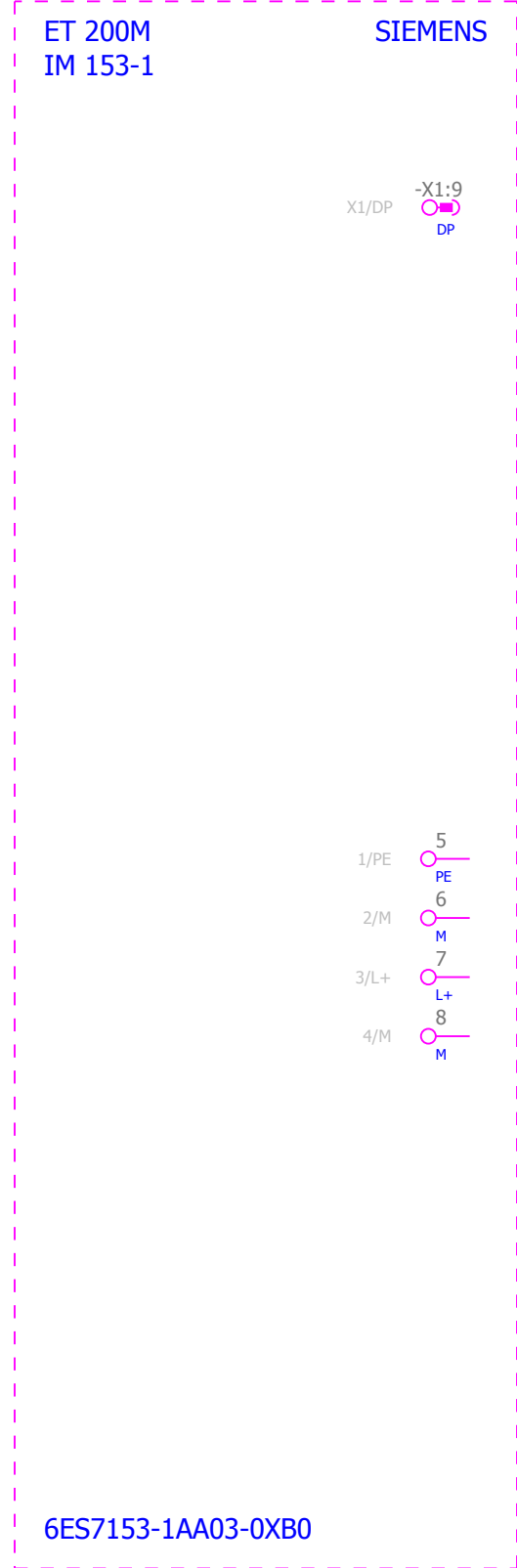

Date	07/06/2015	Esteban Bacilio	CAPSA FOOD- CENTRAL LECHERA ASTURIANA DE YOGURT - TFM	ESTACION REMOTA (1)	= EB3
Ed.	Esteban				+ EBS
Appr		AUTOMATIZACIÓN DE LINEAS DE PRODUCCIÓN DE YOGURT - TFM			
Modification	Date	Name	Original	Replaced by	Replaced by



# ESTACION REMOTA

## SIEMBRA Y FERMENTOS

+ET2-B5  
 +ET2/21.0  
 +ET2/22.0  
 +ET2/23.0  
 +ET2/24.0  
 Rack Y  
 Slot 05  
 SIE.6ES7322-1BL00-0AA0

+ET2-B6  
 +ET2/28.0  
 +ET2/29.0  
 +ET2/30.0  
 +ET2/31.0  
 Rack Y  
 Slot 05  
 SIE.6ES7322-1BL00-0AA0

S7-300  
 SM 322 DO 32 x DC24V/0,5A

SIEMENS

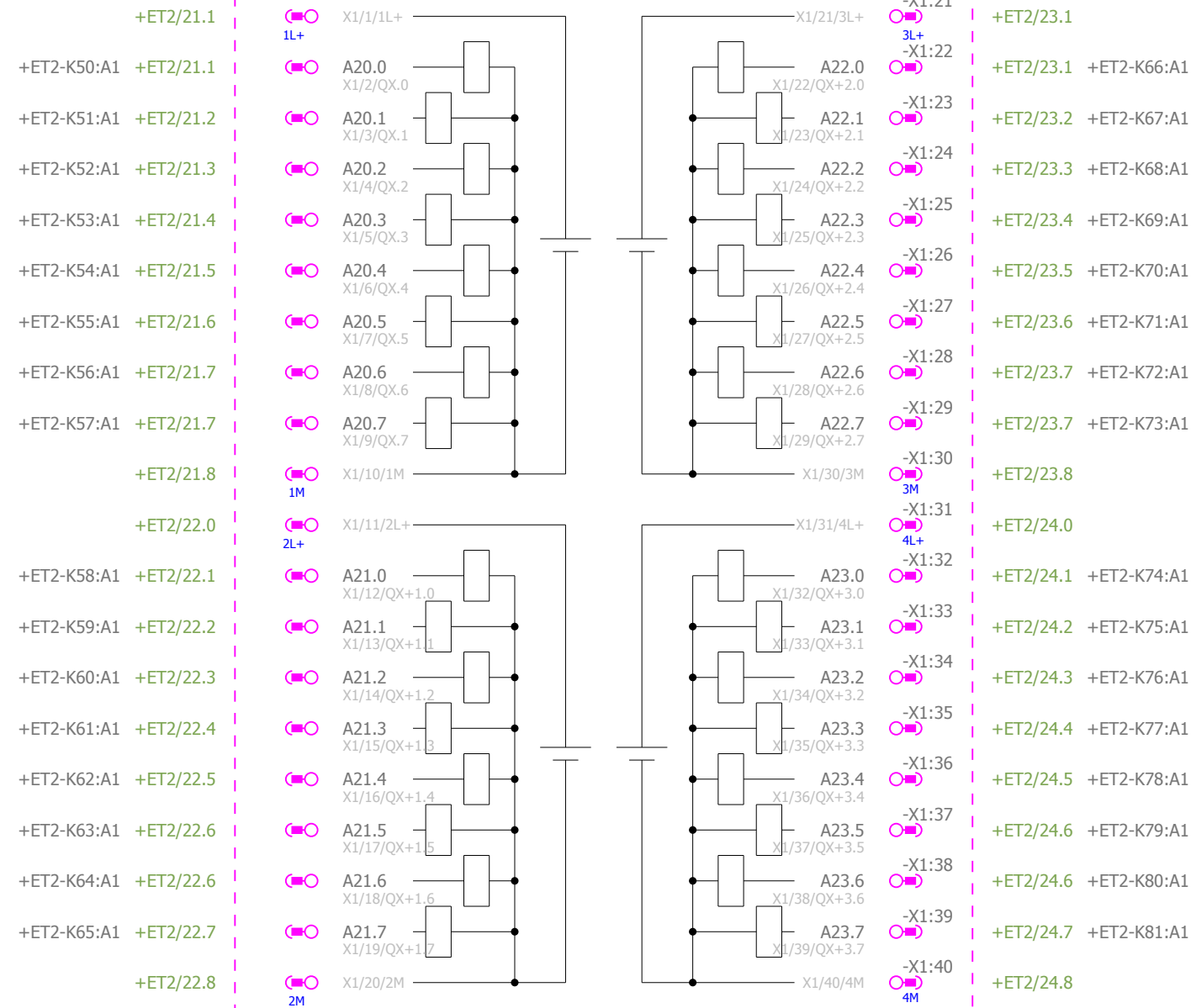

6ES7322-1BL00-0AA0

S7-300  
 SM 322 DO 32 x DC24V/0,5A

SIEMENS

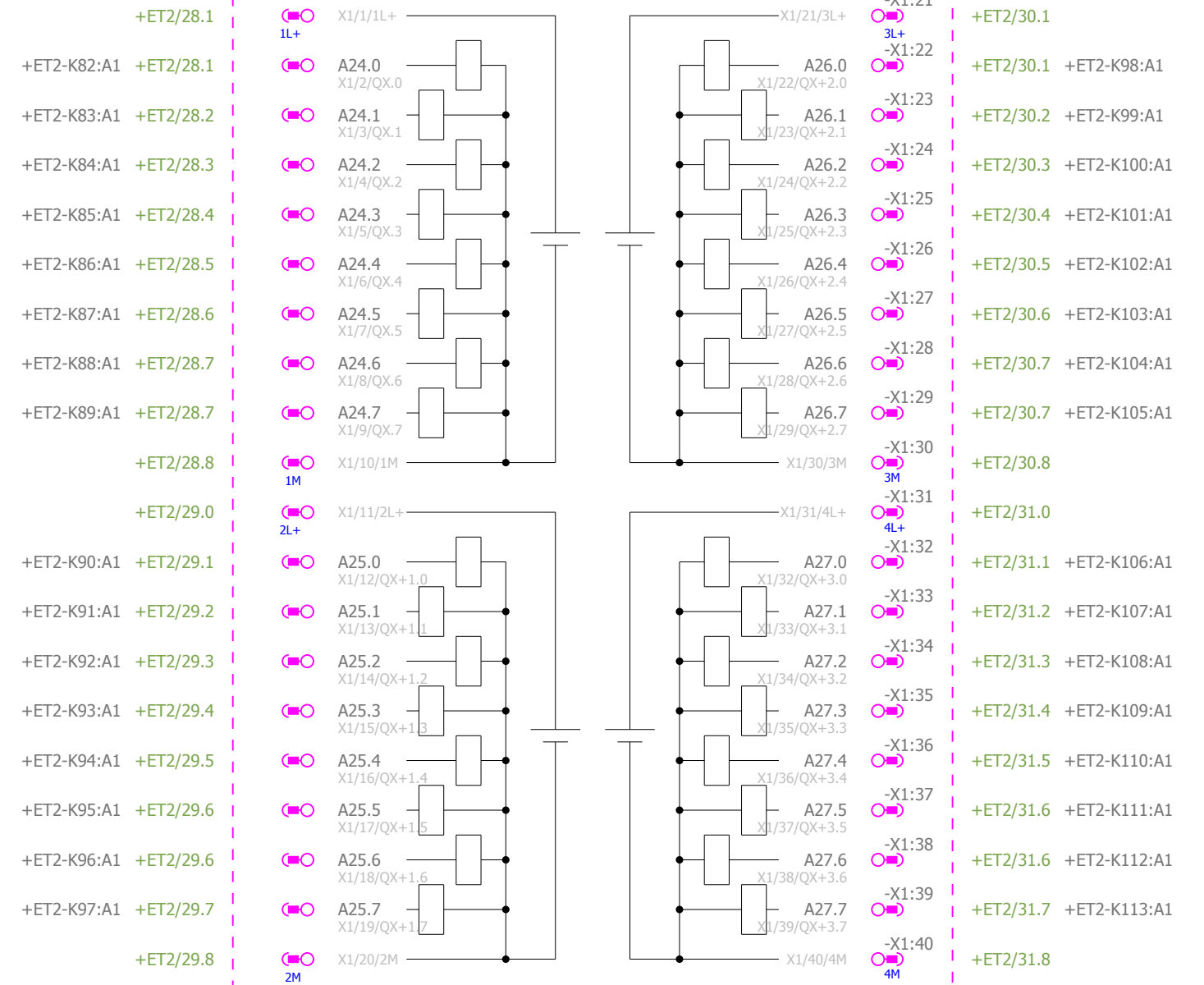

6ES7322-1BL00-0AA0

Date	07/06/2015	Esteban Bacilio	CAPSA FOOD- CENTRAL	ESTACION REMOTA (3)	= EB3
Ed.	Esteban		LECHERA ASTURIANA		+ EBS
Appr		AUTOMATIZACIÓN DE LINEAS DE PRODUCCIÓN DE YOGURT - TFM			
Modification	Date	Name	Original	Replaced by	Replaced by
					Estándar IEC- 61346
					Page 9
					Page 132









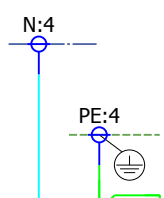
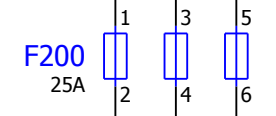
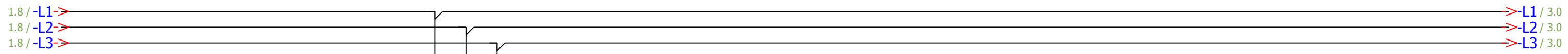

+ET2  
Periferia Descentralizada ET

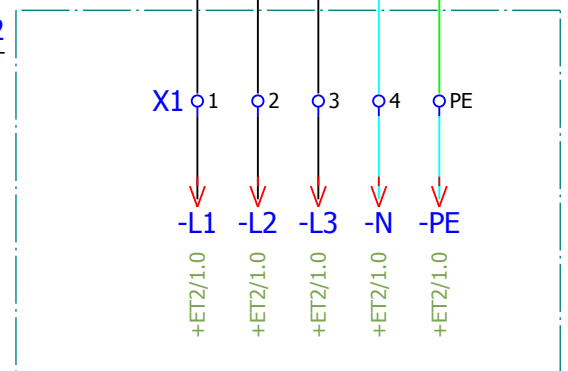

Suministro Estacion Remota

			Date	07/06/2015	Esteban Bacilio	CAPSA FOOD- CENTRAL	Linea de Suministro-Estacion Remota	= EB3
			Ed.	Esteban		LECHERA ASTURIANA		+ ET1
			Appr		AUTOMATIZACIÓN DE LINEAS DE PRODUCCIÓN DE YOGURT - TFM			
Modification	Date	Name	Original		Replaced by			Page 2
							Estándar IEC- 61346	Page 132



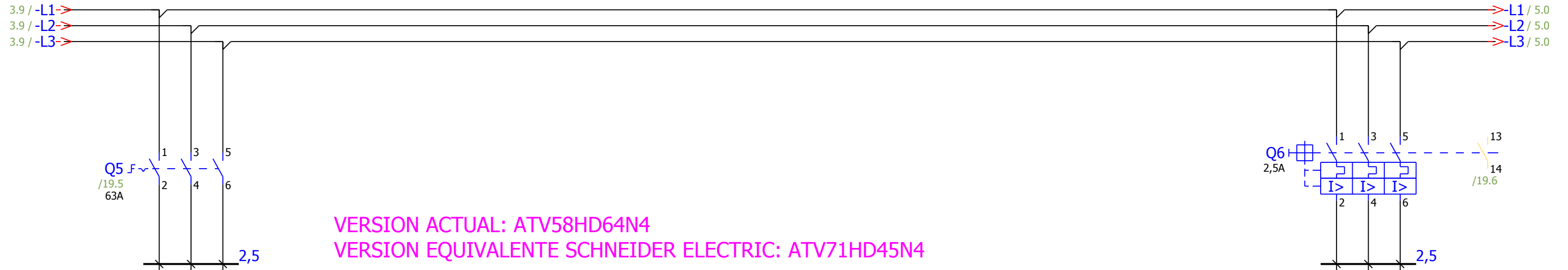

VERSION ACTUAL: ATV58HD64N4  
 VERSION EQUIVALENTE SCHNEIDER ELECTRIC: ATV71HD45N4

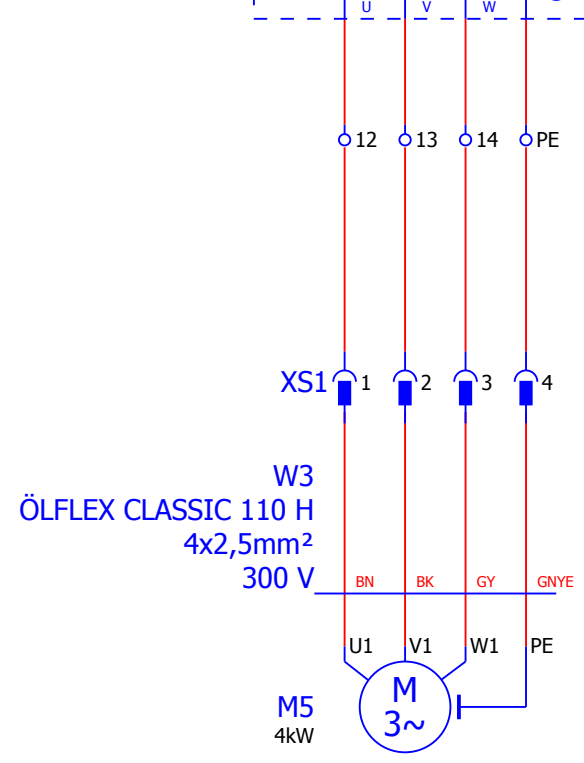
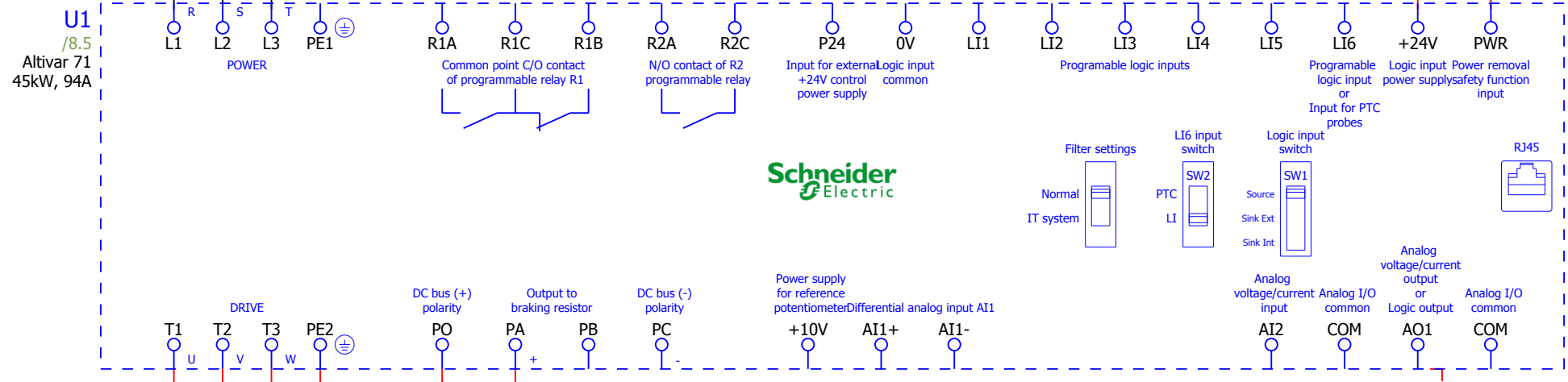

MOTOR HOMOGENIZADOR 1

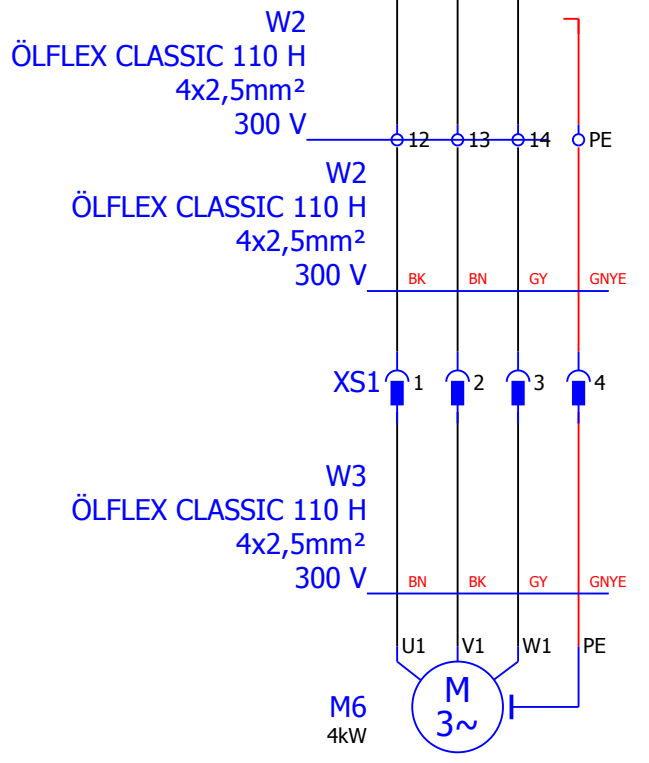

MOTOR HOMOGENIZADOR 2

Date	08/01/2015	Esteban Bacilio	CAPSA FOOD- CENTRAL LECHERA ASTURIANA	Bombas y Motores Pasteurizadores	= EB3
Ed.	DELL		DE YOGURT - TFM		+ ET1
Appr		AUTOMATIZACIÓN DE LINEAS DE PRODUCCIÓN			
Modification	Date	Name	Original	Replaced by	Replaced by
					Estándar IEC- 61346
					Page 4
					Page 132

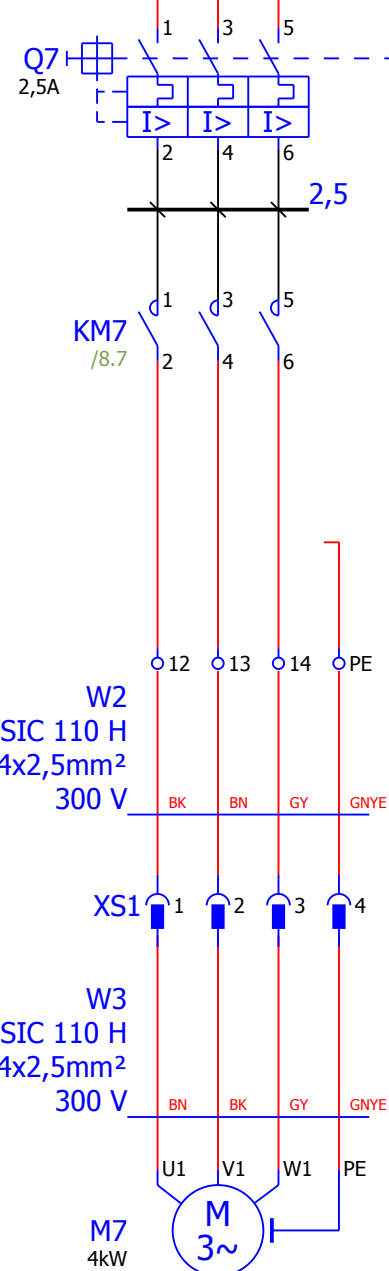
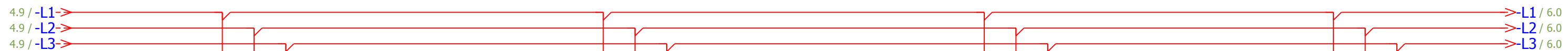

BOMBA AROMAS SIEMBRA 1

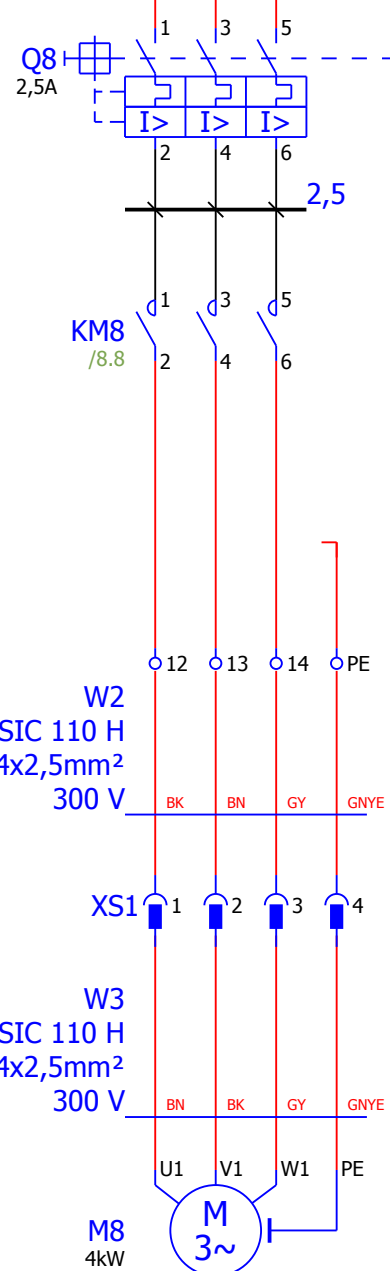

BOMBA CIP Y SIEMBRA

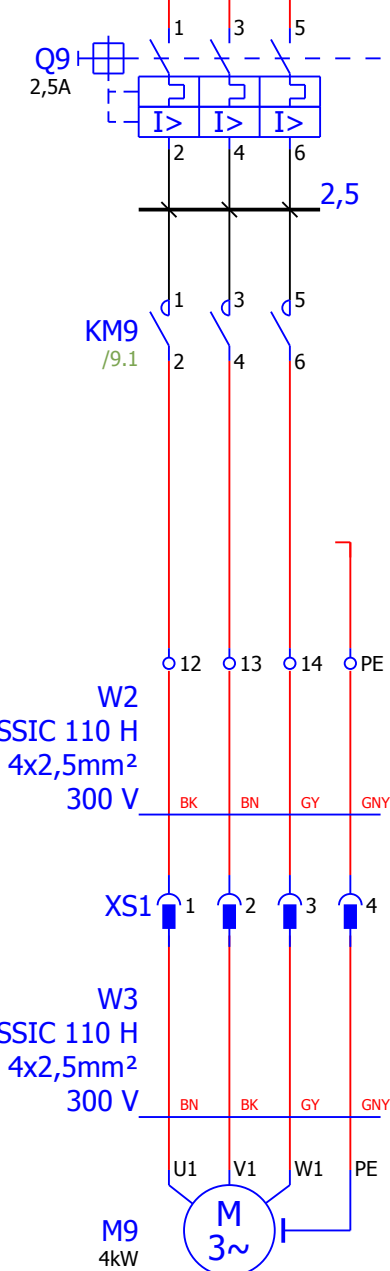

MOTOR AGITADOR SIEMBRA 1

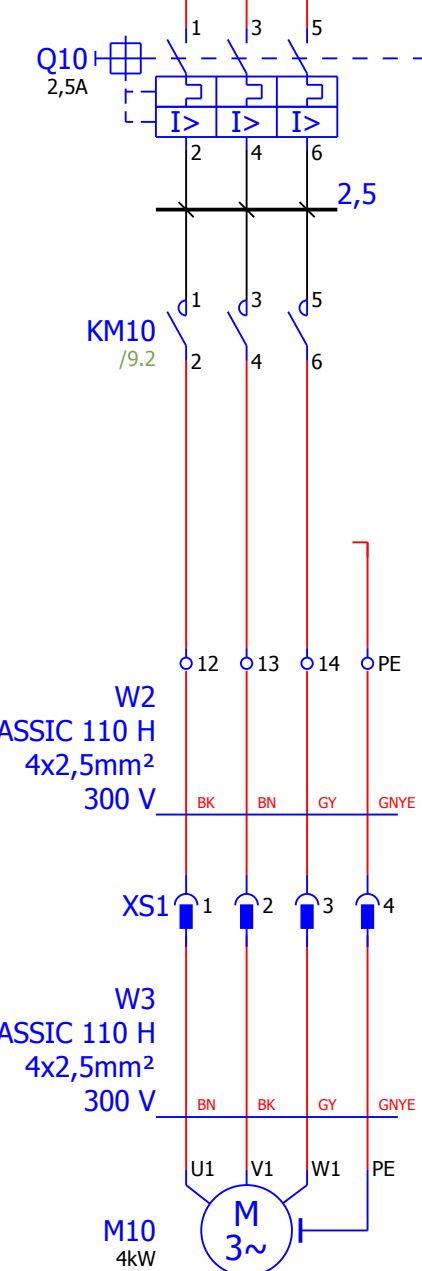

MOTOR AGITADOR SIEMBRA 2

4		6	
Date	06/06/2015	Ed.	Esteban Bacilio
Appr	Esteban	CAPSA FOOD- CENTRAL LECHERA ASTURIANA DE YOGURT - TFM	
Modification	Date	Name	Original
		Replaced by	Replaced by
		Bombas y Motores ERCAS y Fermentos	
		= EB3 + ET1	
		Estandar IEC- 61346	
		Page	5
		Page	132



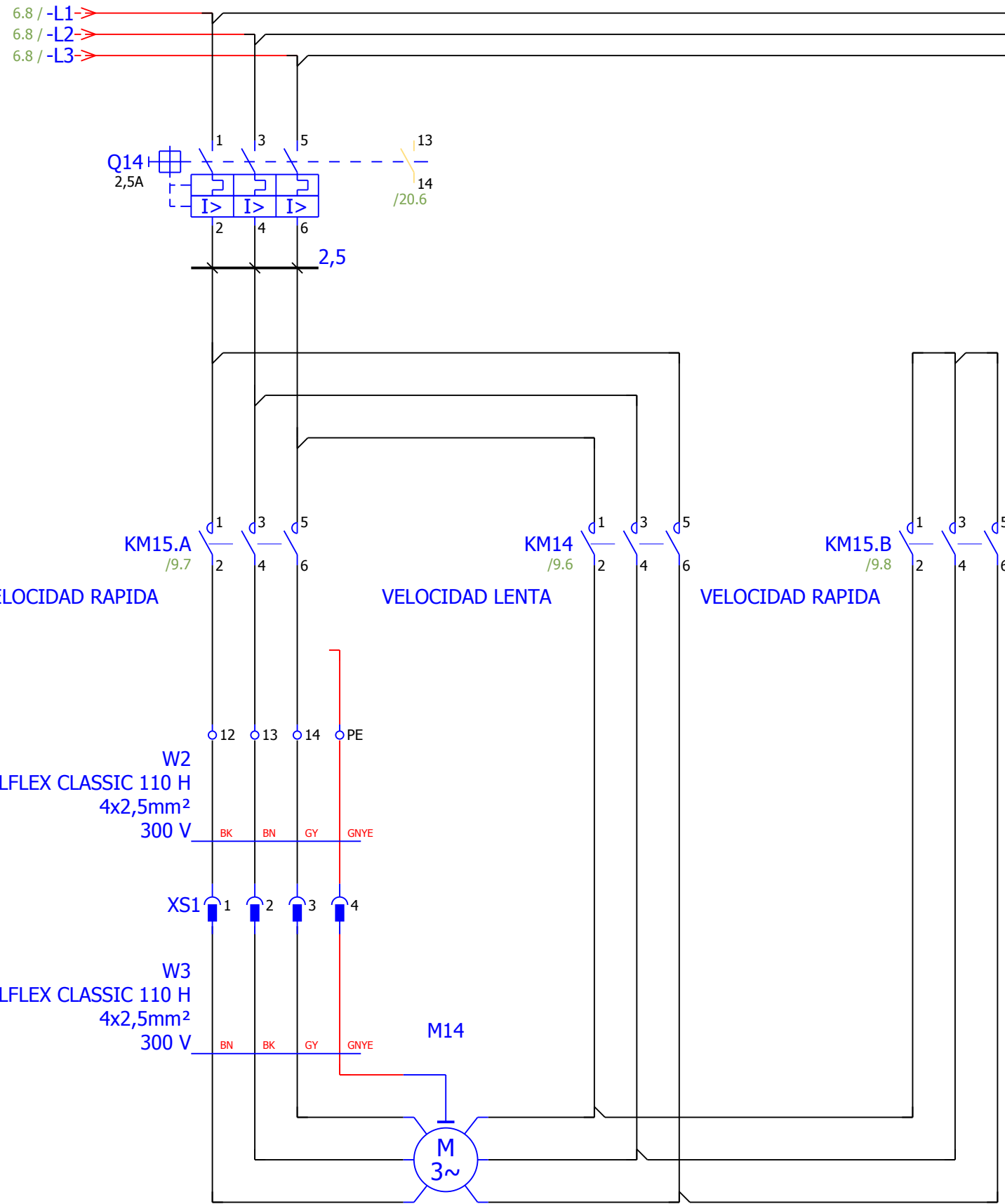

MOTOR AGITADOR FERMENTOS 1  
CONEXION DAHLANDER

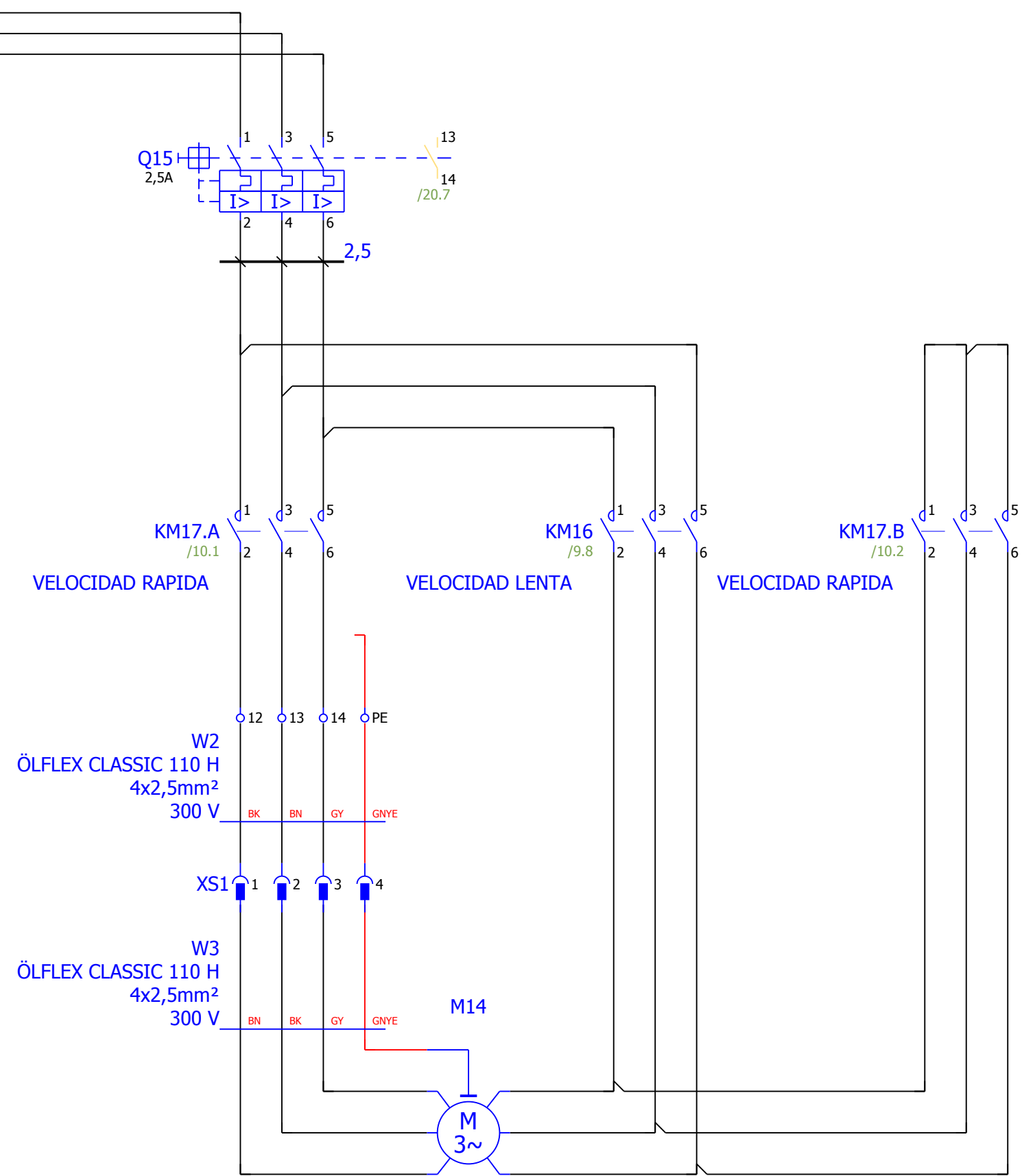

MOTOR AGITADOR FERMENTOS 2  
CONEXION DAHLANDER



ABB.GJL1211001R0101  
 1 2 /3.1  
 3 4 /3.1  
 5 6 /3.2  
 13 14 /20.7

ABB.GJL1211001R0101  
 1 2 /3.3  
 3 4 /3.4  
 5 6 /3.4  
 13 14 /21.1

ABB.GJL1211001R0101  
 1 2 /3.6  
 3 4 /3.6  
 5 6 /3.6  
 13 14 /21.2

ABB.GJL1211001R0101  
 1 2 /3.8  
 3 4 /3.8  
 5 6 /3.8  
 13 14 /21.3

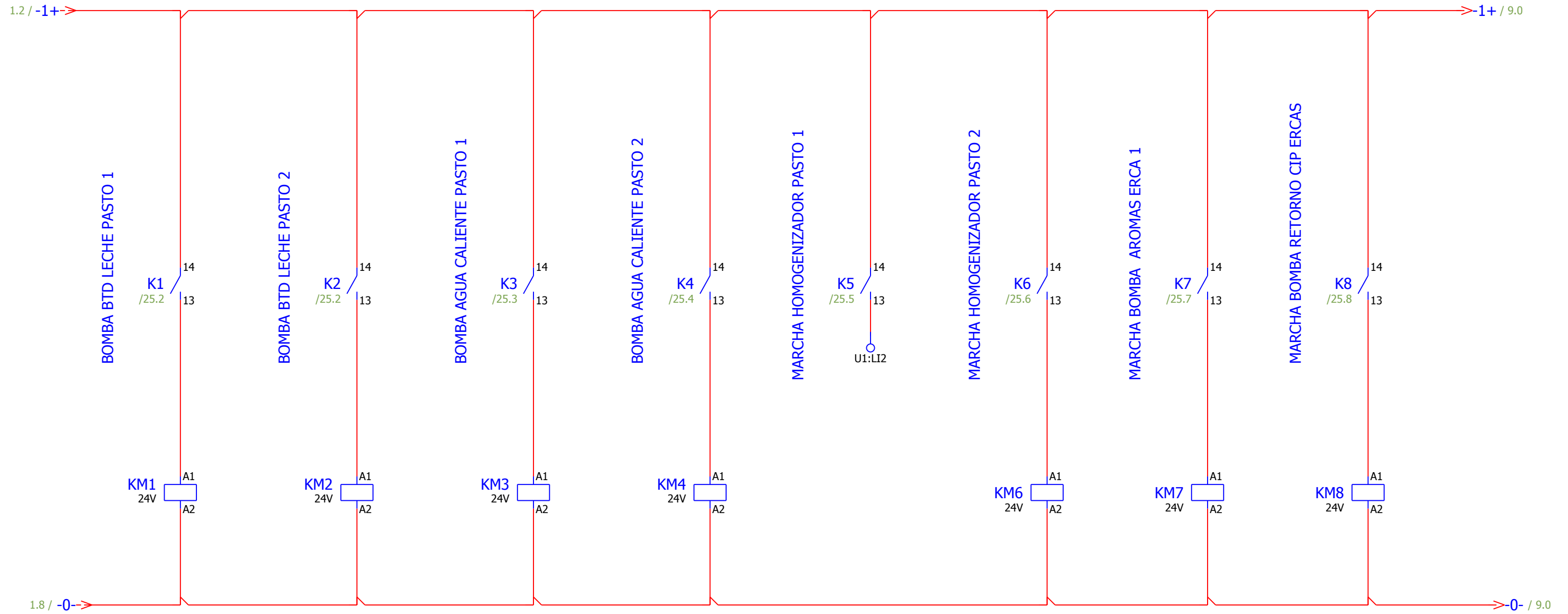
ABB.GJL1211001R0101  
 1 2 /4.8  
 3 4 /4.8  
 5 6 /4.8  
 13 14 /21.4

ABB.GJL1211001R0101  
 1 2 /5.1  
 3 4 /5.1  
 5 6 /5.2  
 13 14 /21.5

ABB.GJL1211001R0101  
 1 2 /5.3  
 3 4 /5.4  
 5 6 /5.4  
 13 14 /21.6

			Date	14/06/2015	Esteban Bacilio		CAPSA FOOD- CENTRAL LECHERA ASTURIANA DE YOGURT - TFM		Preaccionadores de Equipos de Potencia		= EB3 + ET1	
			Ed.	Esteban	AUTOMATIZACIÓN DE LINEAS DE PRODUCCIÓN DE YOGURT - TFM						Estandar IEC- 61346	
			Appr		Replaced by		Replaced by				Page 8	
Modification	Date	Name	Original								Page 132	





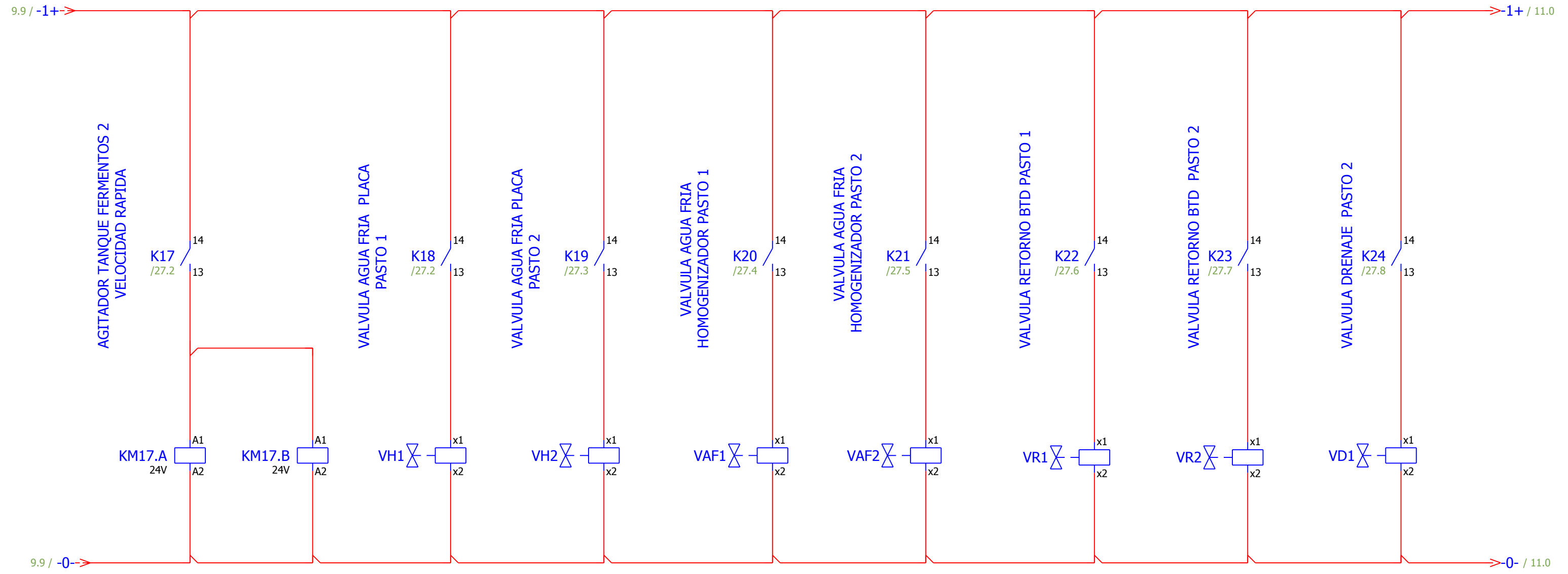

- |                     |                     |
|---------------------|---------------------|
| ABB.GJL1211001R0101 | ABB.GJL1211001R0101 |
| 1 2 /7.6            | 1 2 /7.9            |
| 3 4 /7.6            | 3 4 /7.9            |
| 5 6 /7.6            | 5 6 /7.9            |
| 13 14 /22.7         | 13 14 /23.1         |

Date	07/06/2015	Esteban Bacilio	CAPSA FOOD- CENTRAL LECHERA ASTURIANA	Preaccionadores de Equipos de Potencia	= EB3
Ed.	Esteban		DE YOGURT - TFM		+ ET1
Appr		AUTOMATIZACIÓN DE LINEAS DE PRODUCCIÓN			
Modification	Date	Name	Original	Replaced by	Replaced by
					Estandar IEC- 61346
					Page 10
					Page 132

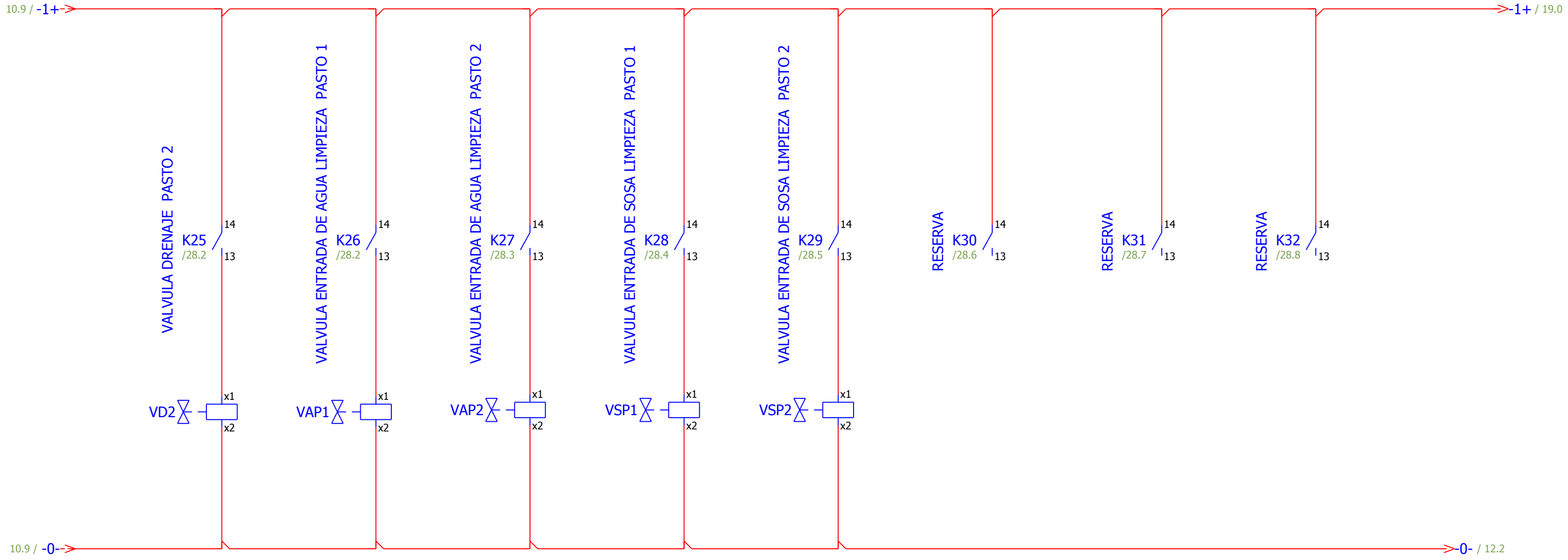

Date	07/06/2015	Esteban Bacilio	CAPSA FOOD- CENTRAL LECHERA ASTURIANA	Preaccionadores de Equipos de Potencia	= EB3
Ed.	Esteban		DE YOGURT - TFM		+ ET1
Appr		AUTOMATIZACIÓN DE LINEAS DE PRODUCCIÓN			
Modification	Date	Name	Original	Replaced by	Replaced by
					Estándar IEC- 61346
					Page 11
					Page 132





# SIEMENS MODULO DE ENTRADAS ANALOGICAS

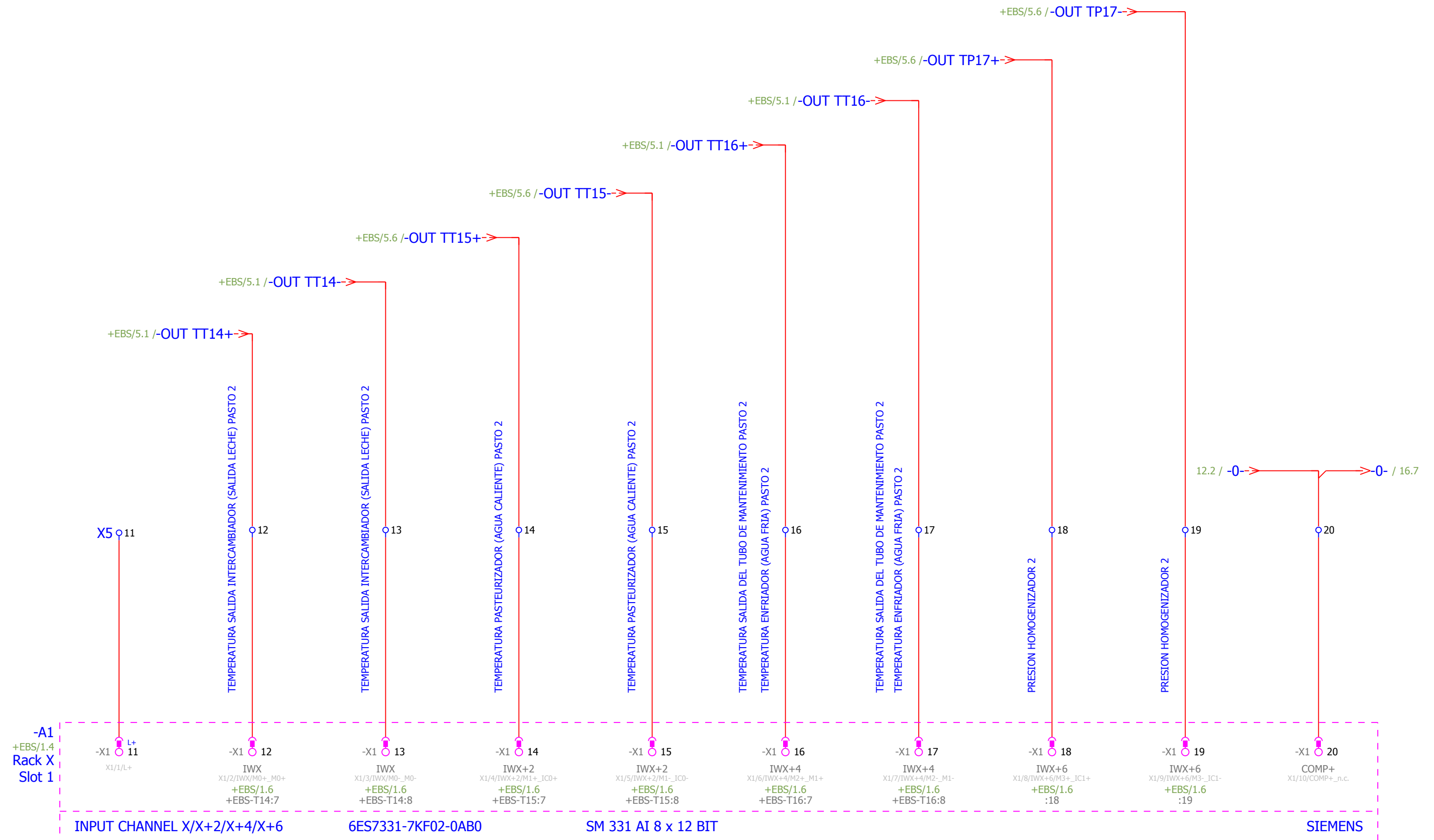

Date	07/06/2015	Esteban Bacilio	CAPSA FOOD- CENTRAL LECHERA ASTURIANA	Entradas Analog.CPU S7-300	= EB3
Ed.	Esteban		DE YOGURT - TFM		+ ET1
Appr					
Modification	Date	Name	Original	Replaced by	Replaced by
					Estandar IEC- 61346
					Page 14
					Page 132

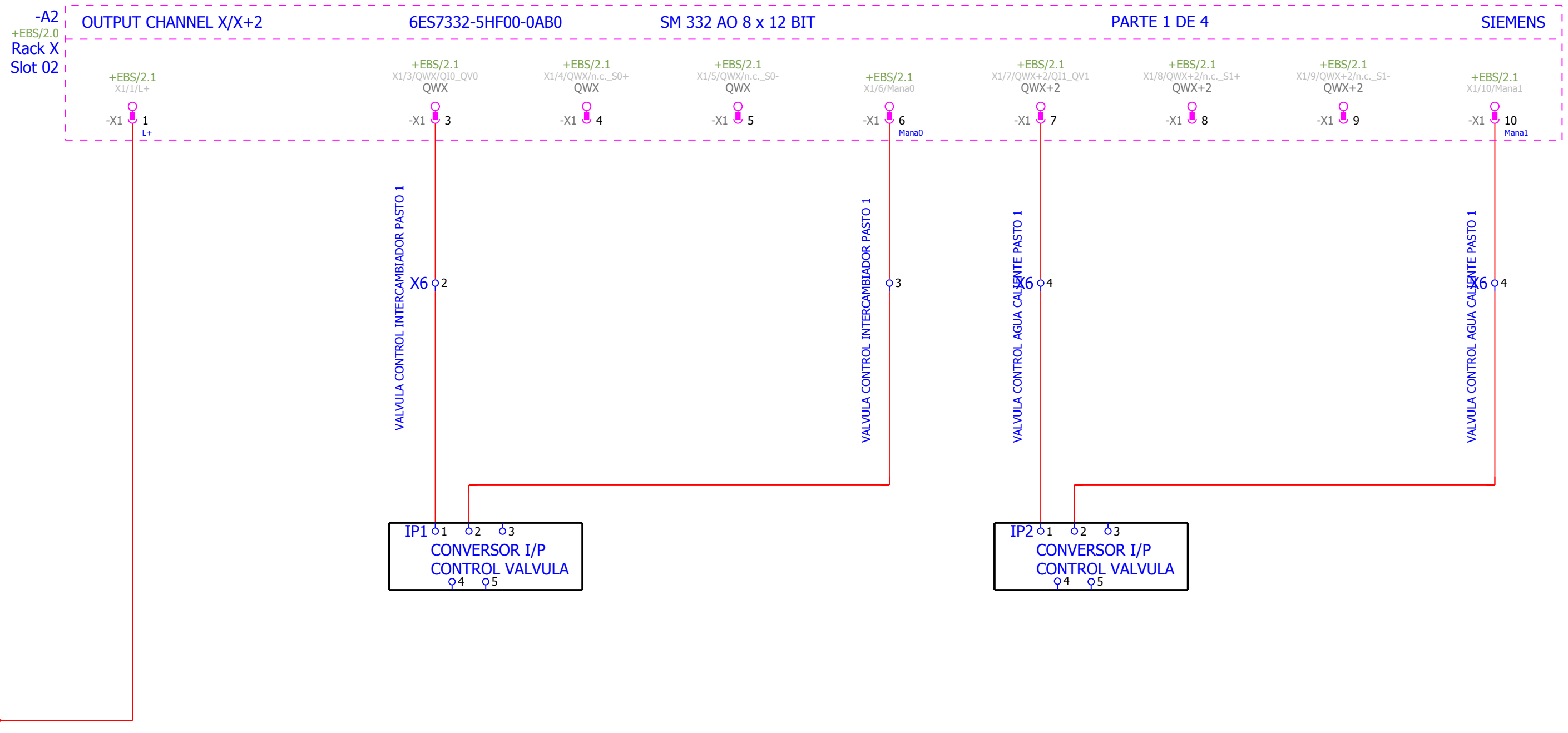

# SIEMENS MODULO DE SALIDAS ANALOGICAS

Date	07/06/2015	Esteban Bacilio	CAPSA FOOD- CENTRAL LECHERA ASTURIANA	Salidas Analog.CPU S7-300	= EB3
Ed.	Esteban		DE YOGURT - TFM		+ ET1
Appr		AUTOMATIZACIÓN DE LINEAS DE PRODUCCIÓN			
Modification	Date	Name	Original	Replaced by	Replaced by
					Estándar IEC- 61346
					Page 15
					Page 132



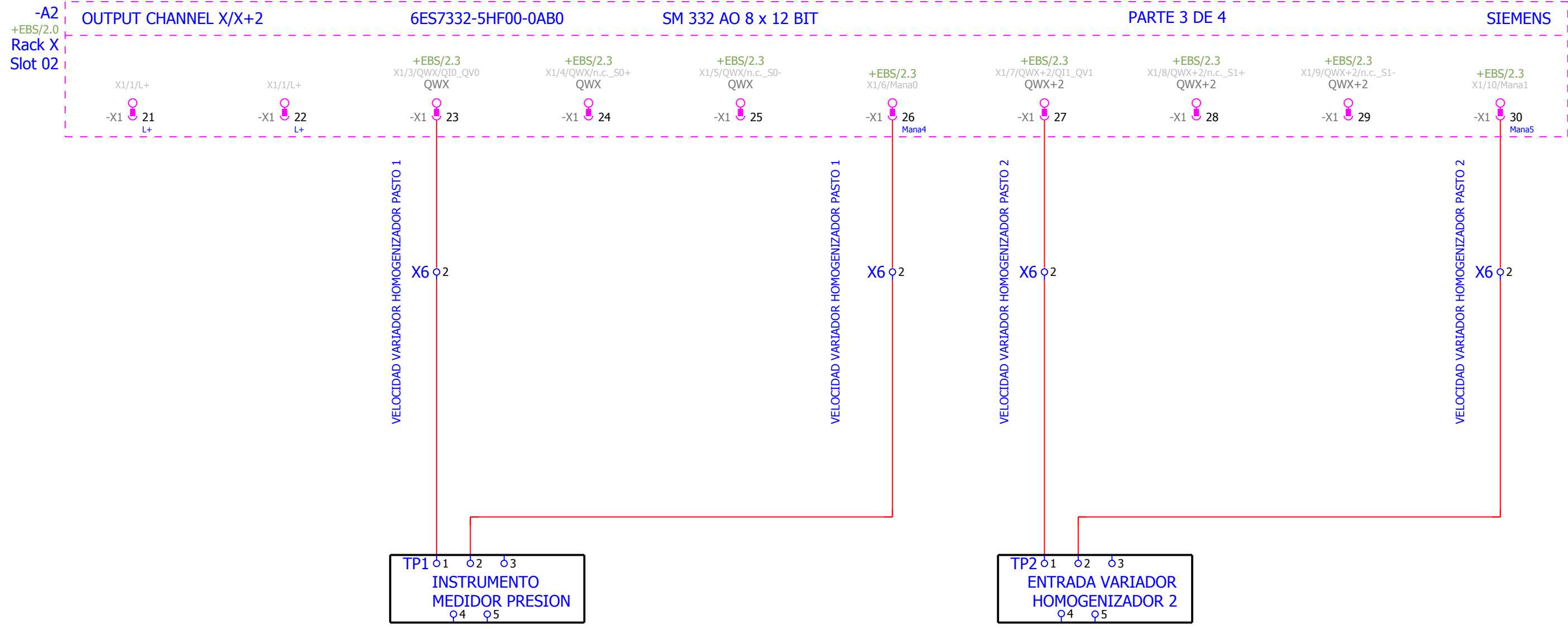

# SIEMENS MODULO DE SALIDAS ANALOGICAS

Date	07/06/2015	Esteban Bacilio	CAPSA FOOD- CENTRAL LECHERA ASTURIANA	Salidas Analog.CPU S7-300	= EB3
Ed.	Esteban		DE YOGURT - TFM		+ ET1
Appr		AUTOMATIZACIÓN DE LINEAS DE PRODUCCIÓN			
Modification	Date	Name	Original	Replaced by	Replaced by
					Estándar IEC- 61346
					Page 17
					Page 132





# SIEMENS MODULO DE ENTRADAS DIGITALES (A3)

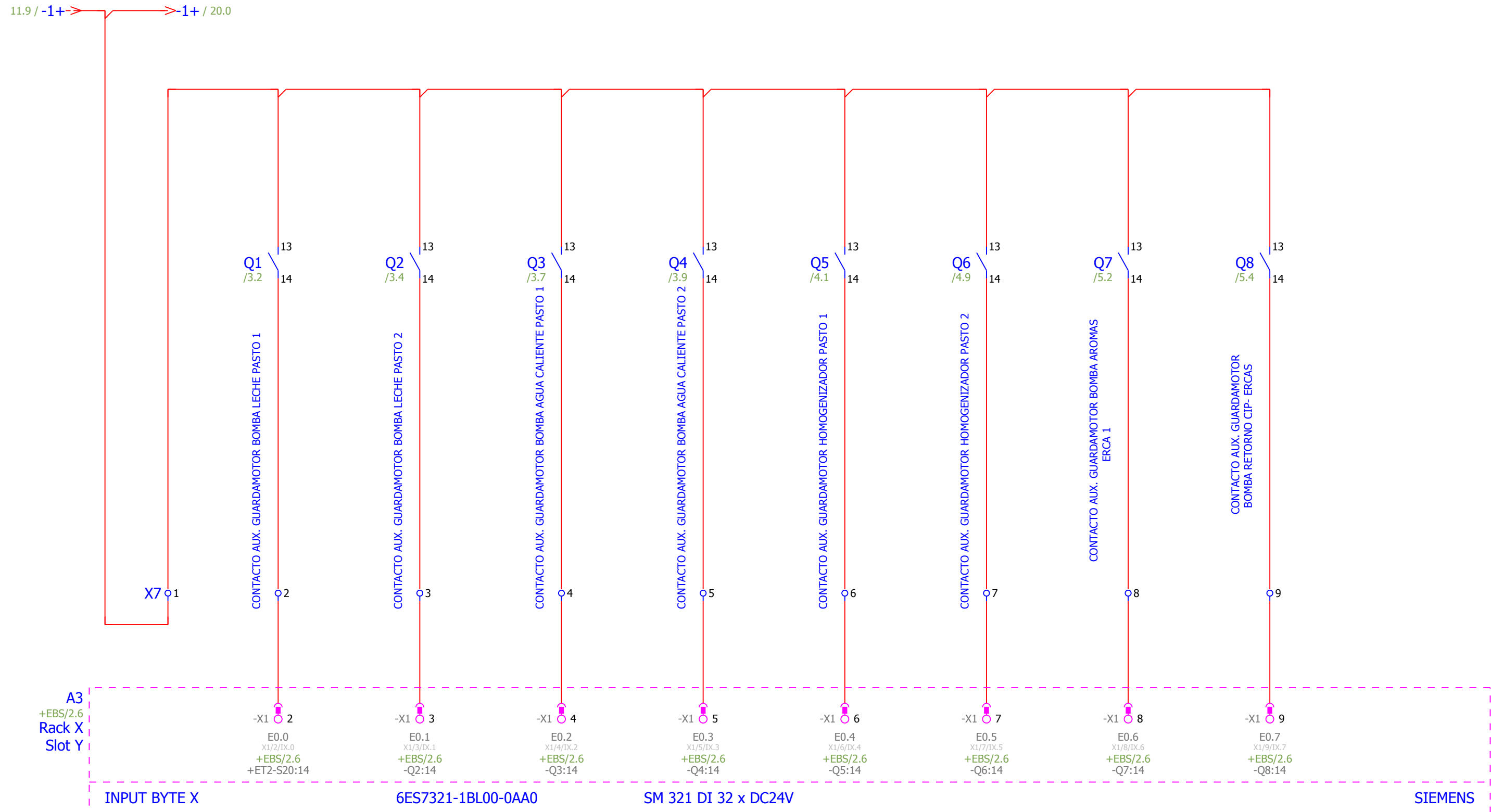

Date	07/06/2015	Esteban Bacilio	CAPSA FOOD- CENTRAL LECHERA ASTURIANA	Entradas Digitales Modulo (A3) S7-300	= EB3
Ed.	Esteban		DE YOGURT - TFM		+ ET1
Appr					
Modification	Date	Name	Original	Replaced by	Replaced by
					Estandar IEC- 61346
					Page 19
					Page 132



# SIEMENS MODULO DE ENTRADAS DIGITALES (A3)

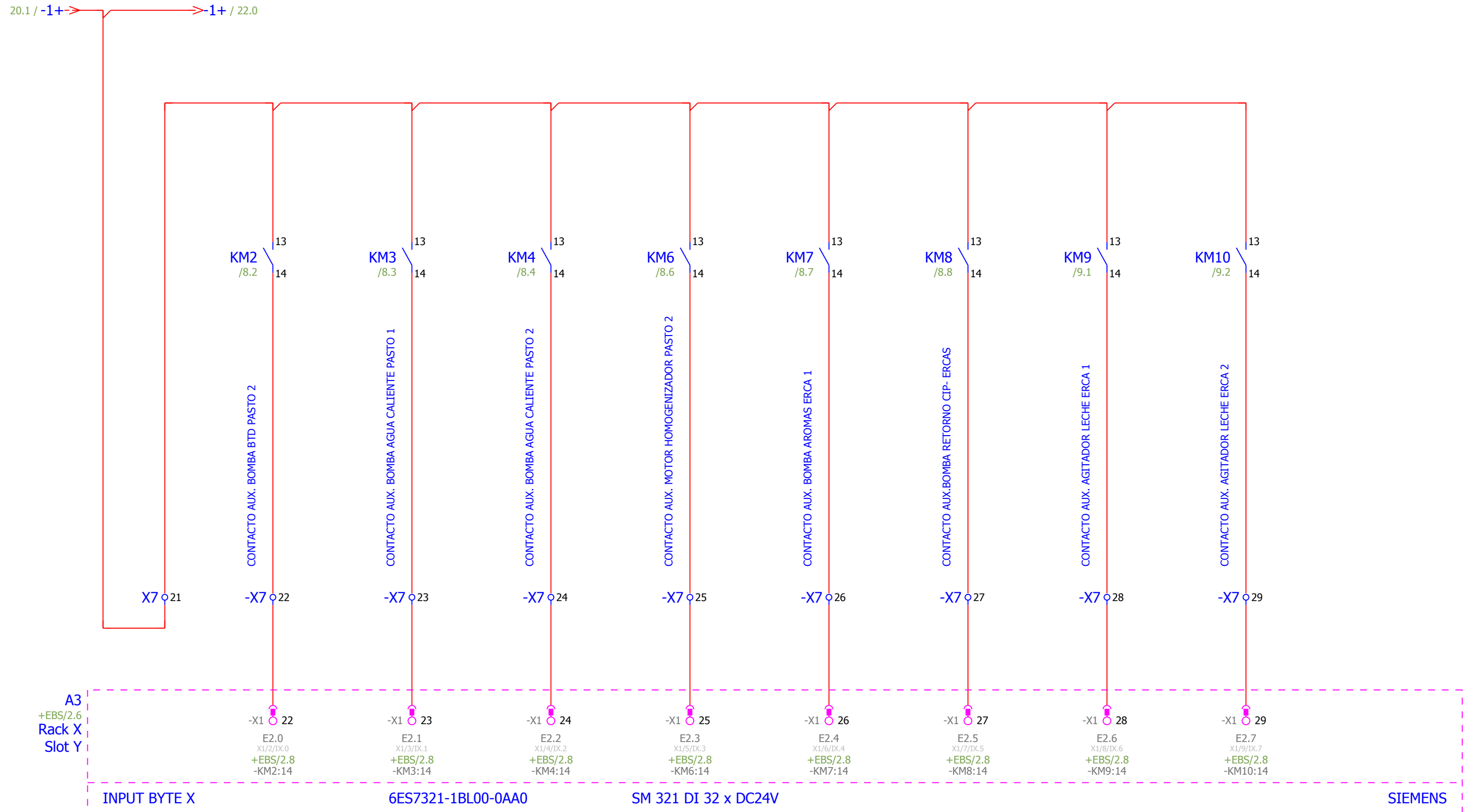

Date	07/06/2015	Esteban Bacilio	CAPSA FOOD- CENTRAL LECHERA ASTURIANA	Entradas Digitales Modulo (A3) S7-300	= EB3
Ed.	Esteban		DE YOGURT - TFM		+ ET1
Appr					
Modification	Date	Name	Original	Replaced by	Replaced by
					Estandar IEC- 61346
					Page 21
					Page 132





# SIEMENS MODULO DE ENTRADAS DIGITALES (A4)

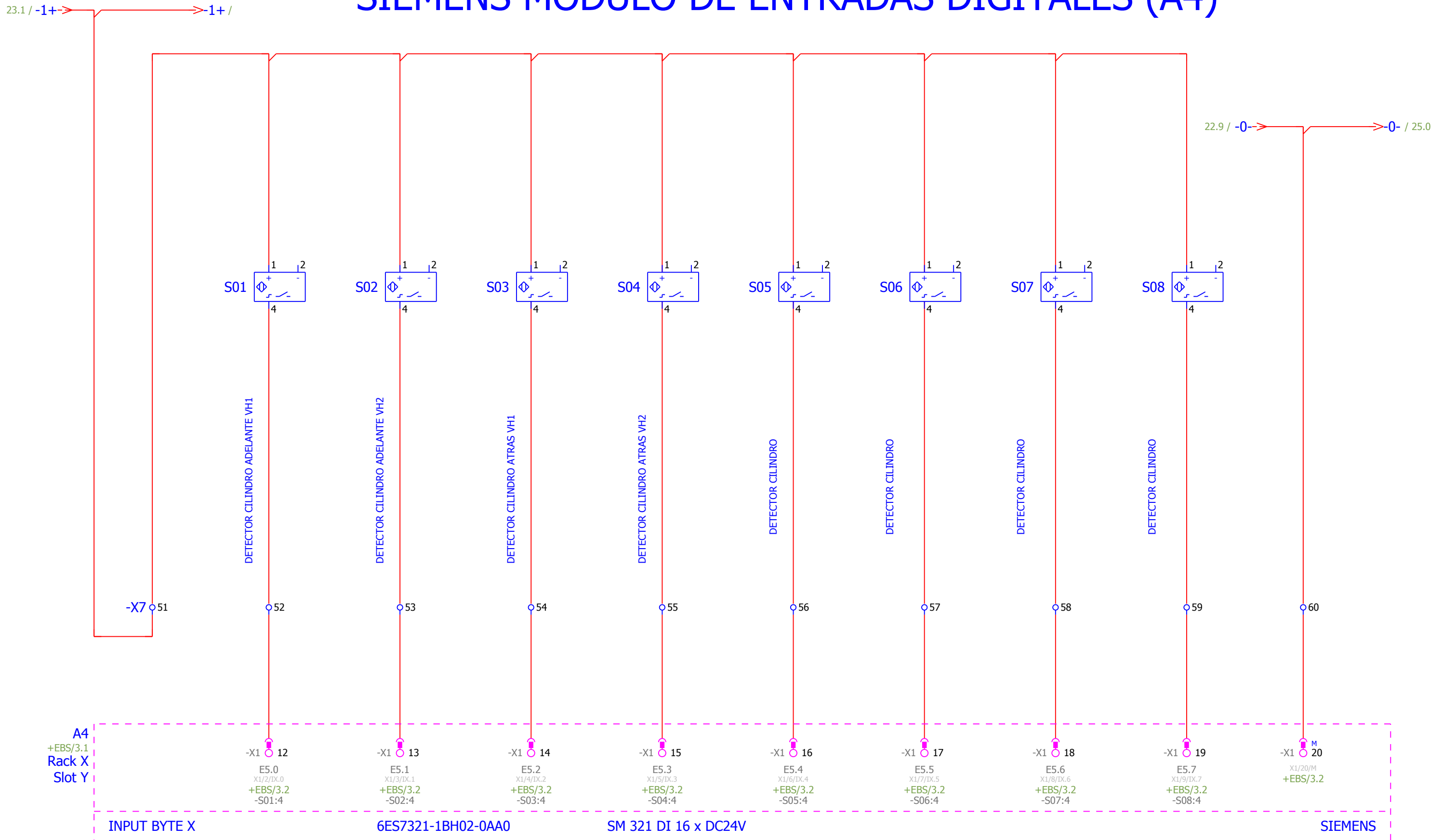

Date	07/06/2015	Esteban Bacilio	CAPSA FOOD- CENTRAL LECHERA ASTURIANA	Entradas Digitales Modulo A4	= EB3
Ed.	Esteban		DE YOGURT - TFM		+ ET1
Appr		AUTOMATIZACIÓN DE LINEAS DE PRODUCCIÓN DE YOGURT - TFM			
Modification	Date	Name	Original	Replaced by	Replaced by
					Estándar IEC- 61346
					Page 24
					Page 132

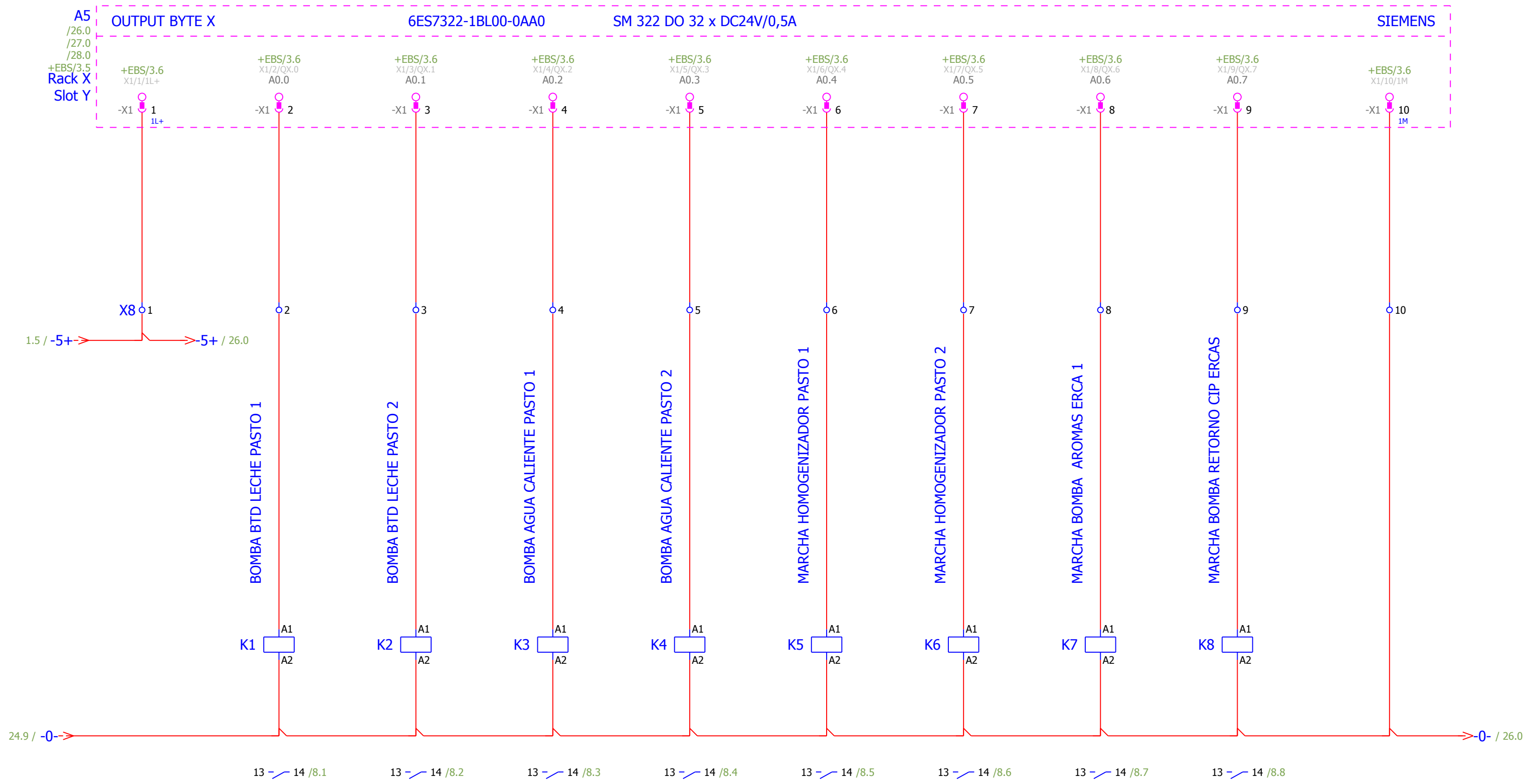

# SIEMENS MODULO DE SALIDAS DIGITALES (A5)

Date	07/06/2015	Esteban Bacilio	CAPSA FOOD- CENTRAL LECHERA ASTURIANA	Salidas Digitales Modulo (A5) ET200M	= EB3
Ed.	Esteban		DE YOGURT - TFM		+ ET1
Appr		AUTOMATIZACIÓN DE LINEAS DE PRODUCCIÓN			
Modification	Date	Name	Original	Replaced by	Replaced by
					Estándar IEC- 61346
					Page 25
					Page 132



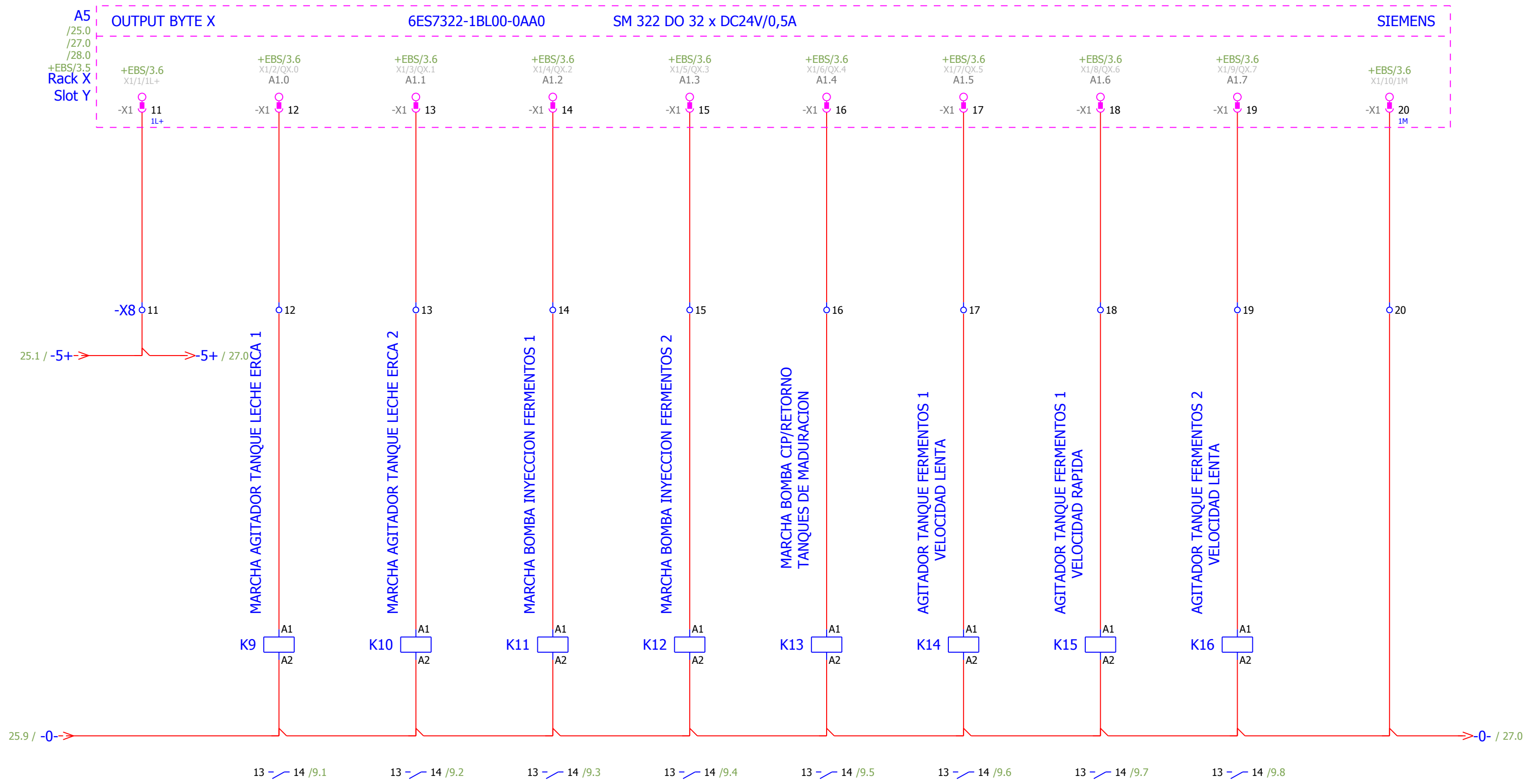

# SIEMENS MODULO DE SALIDAS DIGITALES (A5)

Date	07/06/2015	Esteban Bacilio	CAPSA FOOD- CENTRAL LECHERA ASTURIANA	Salidas Digitales Modulo (A5) ET200M	= EB3
Ed.	Esteban		DE YOGURT - TFM		+ ET1
Appr		AUTOMATIZACIÓN DE LINEAS DE PRODUCCIÓN			
Modification	Date	Name	Original	Replaced by	Replaced by
					Estandar IEC- 61346
					Page 26
					Page 132

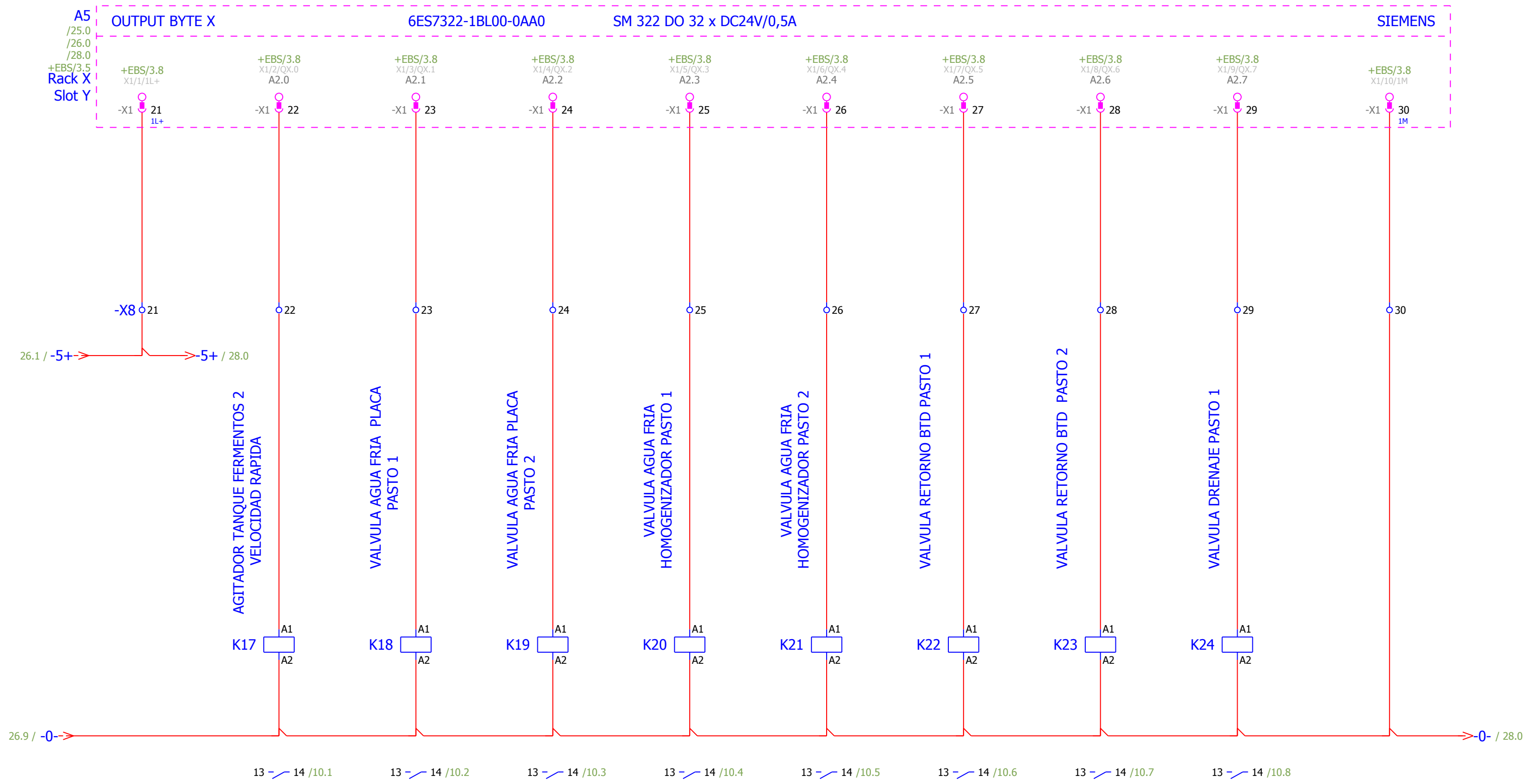

# SIEMENS MODULO DE SALIDAS DIGITALES (A5)

Date	07/06/2015	Esteban Bacilio	CAPSA FOOD- CENTRAL LECHERA ASTURIANA DE YOGURT - TFM	Salidas Digitales Modulo (A5) ET200M	= EB3
Ed.	Esteban				+ ET1
Appr		AUTOMATIZACIÓN DE LINEAS DE PRODUCCIÓN DE YOGURT - TFM			
Modification	Date	Name	Original	Replaced by	Replaced by
					Estándar IEC- 61346
					Page 27
					Page 132

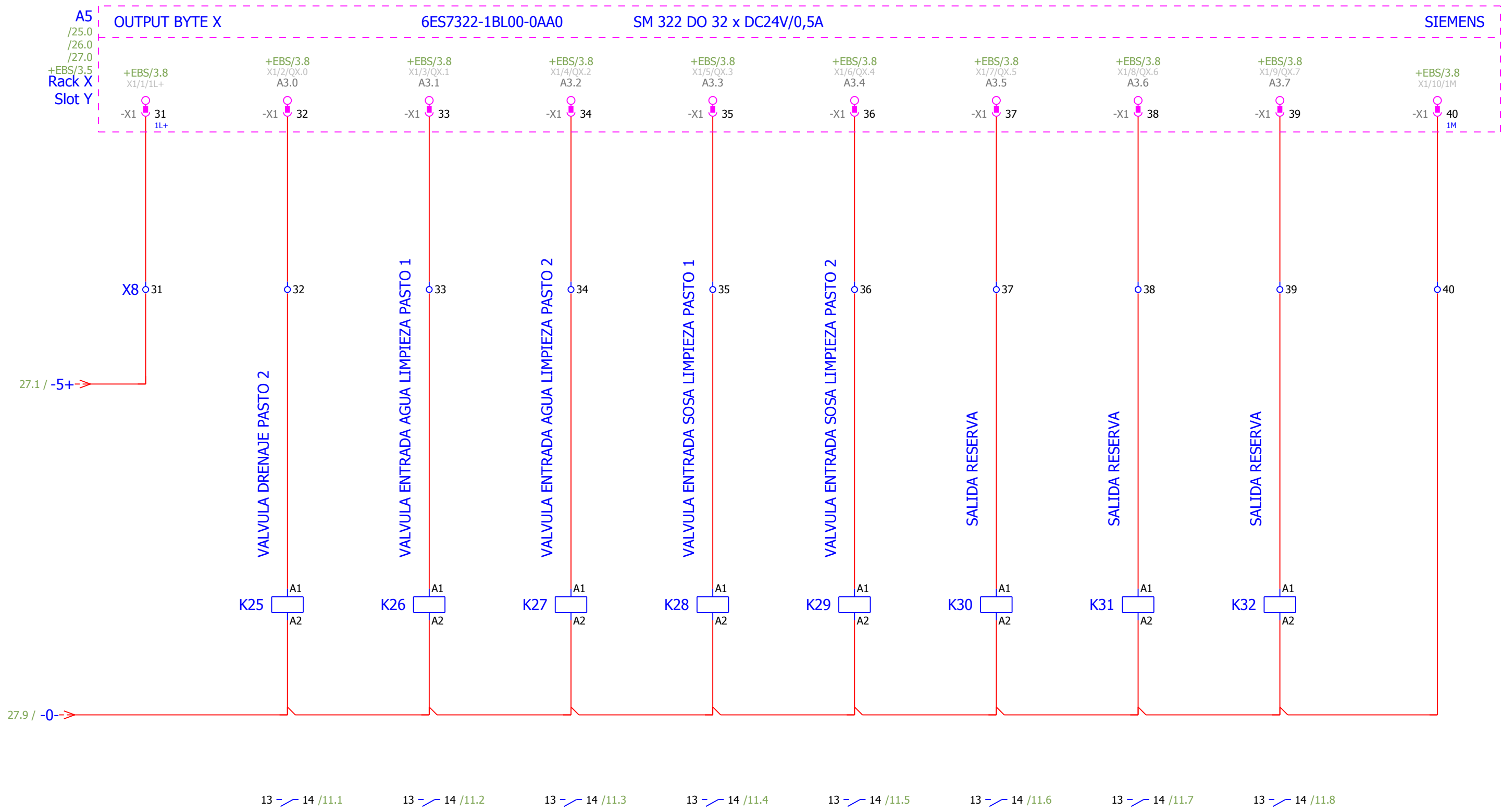

# SIEMENS MODULO DE SALIDAS DIGITALES (A5)

Date	07/06/2015	Esteban Bacilio	CAPSA FOOD- CENTRAL LECHERA ASTURIANA	Salidas Digitales Modulo (A5) ET200M	= EB3
Ed.	Esteban		DE YOGURT - TFM		+ ET1
Appr					
Modification	Date	Name	Original	Replaced by	Replaced by
					Estandar IEC- 61346
					Page 28
					Page 132

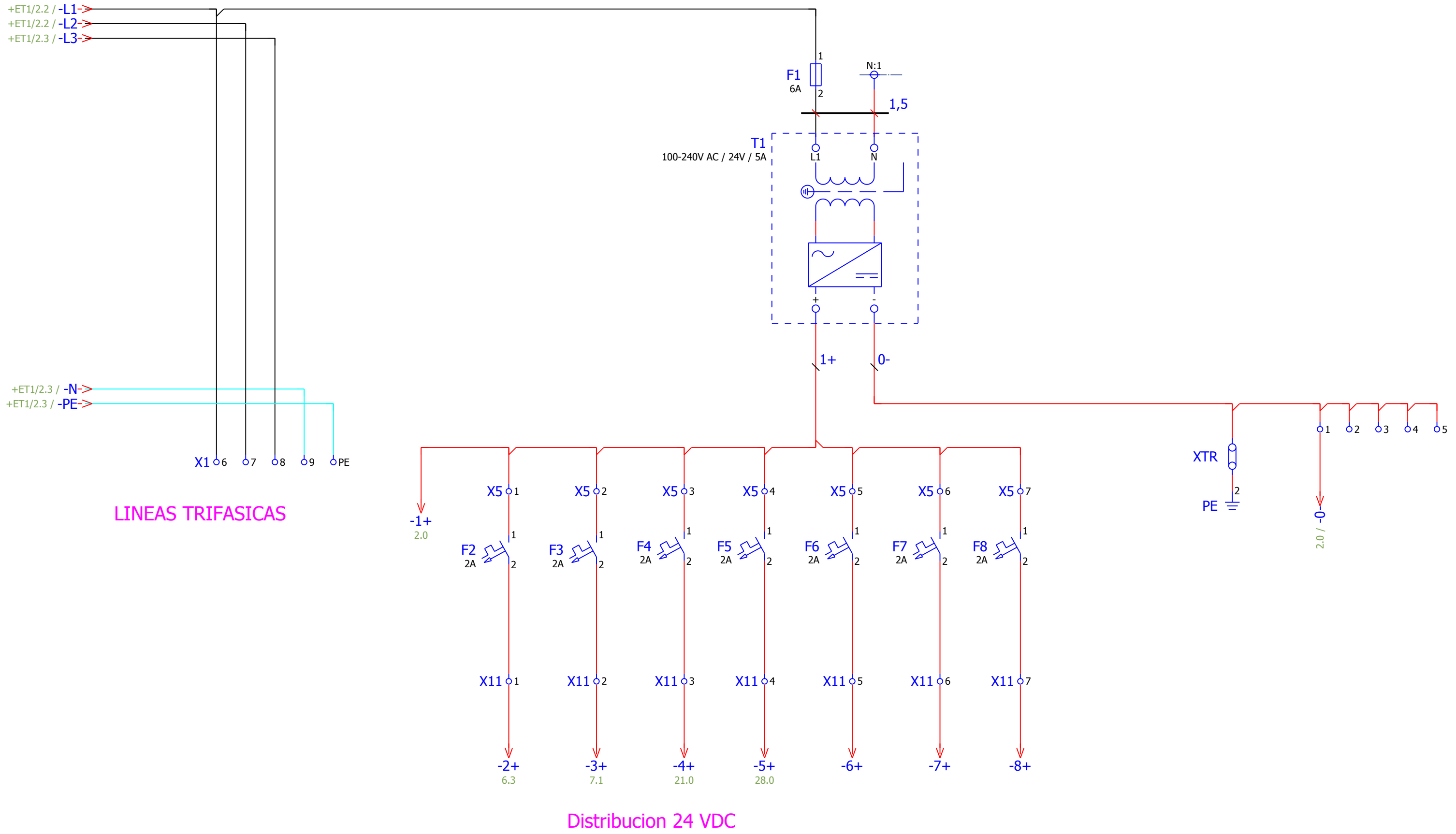

LINEAS TRIFASICAS

Distribucion 24 VDC

+ET1/28				Date: 14/06/2015		Esteban Bacilio		CAPSA FOOD- CENTRAL LECHERA ASTURIANA		Potencia Estacion Remota		= EB3	
				Ed.: Esteban				DE YOGURT - TFM				+ ET2	
				Appr:		AUTOMATIZACIÓN DE LINEAS DE PRODUCCIÓN						Estandar IEC- 61346	
Modification				Date		Name		Original		Replaced by		Page 1	
										Replaced by		Page 132	

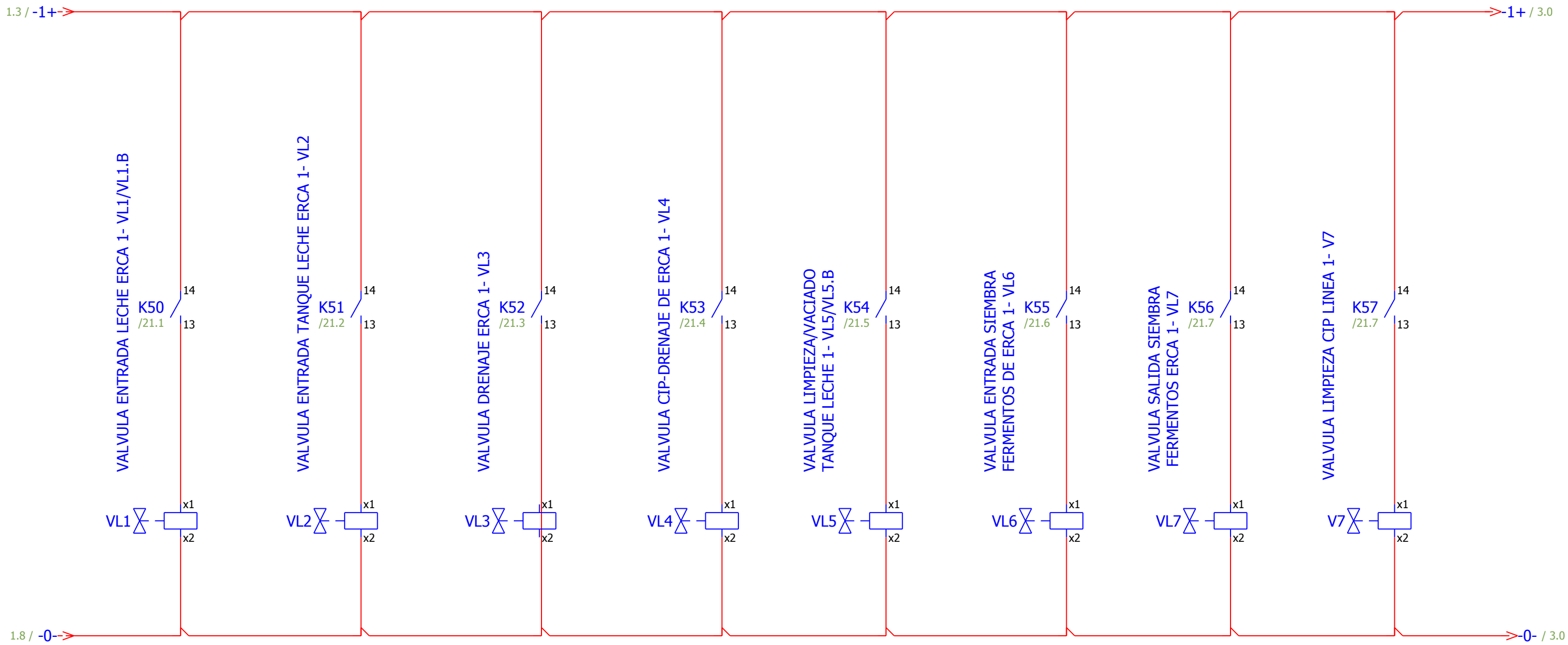

Date	14/06/2015	Esteban Bacilio	CAPSA FOOD- CENTRAL LECHERA ASTURIANA	Preaccionadores de Equipos de Potencia	= EB3
Ed.	Esteban		DE YOGURT - TFM		+ ET2
Appr		AUTOMATIZACIÓN DE LINEAS DE PRODUCCIÓN			
Modification	Date	Name	Original	Replaced by	Replaced by
					Estandar IEC- 61346
					Page 2
					Page 132

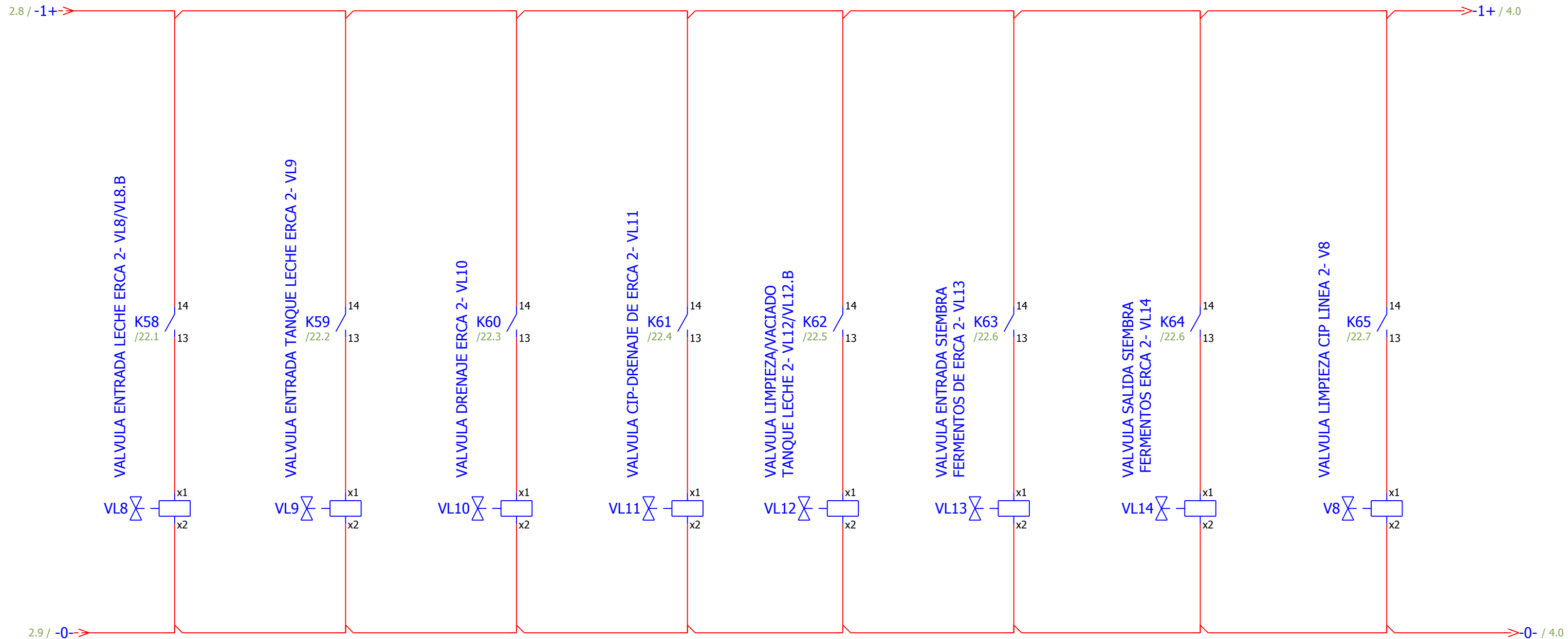

		Date	14/06/2015	Esteban Bacilio		CAPSA FOOD- CENTRAL	Preaccionadores de Equipos de Potencia		= EB3	
		Ed.	Esteban			LECHERA ASTURIANA			+ ET2	
		Appr		AUTOMATIZACIÓN DE LINEAS DE PRODUCCIÓN DE YOGURT - TFM				Estandar IEC- 61346		Page 3
Modification	Date	Name	Original	Replaced by	Replaced by					Page 132

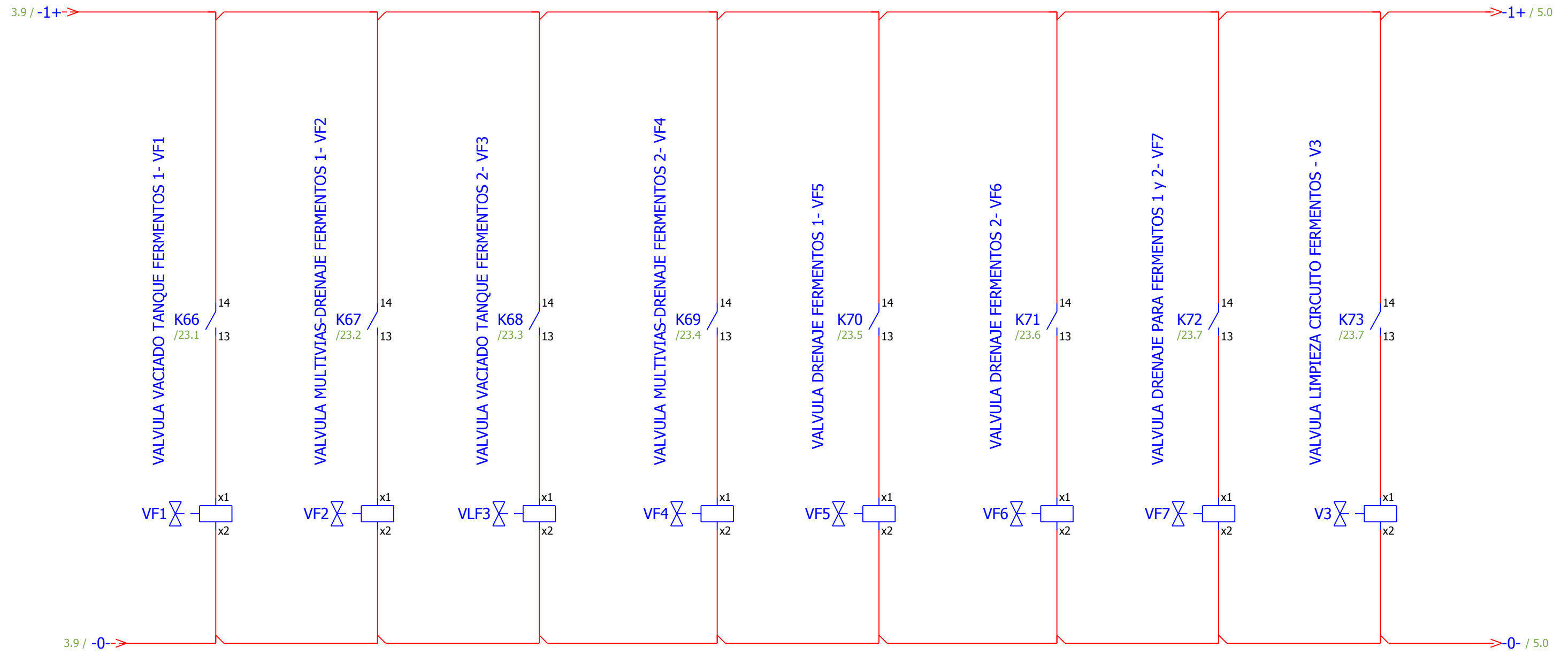

		Date	14/06/2015	Esteban Bacilio		CAPSA FOOD- CENTRAL LECHERA ASTURIANA		Preaccionadores de Equipos de Potencia		= EB3	
		Ed.	Esteban	AUTOMATIZACIÓN DE LINEAS DE PRODUCCIÓN DE YOGURT - TFM						+ ET2	
		Appr								Estandar IEC- 61346	
Modification	Date	Name	Original	Replaced by	Replaced by					Page	4
										Page	132

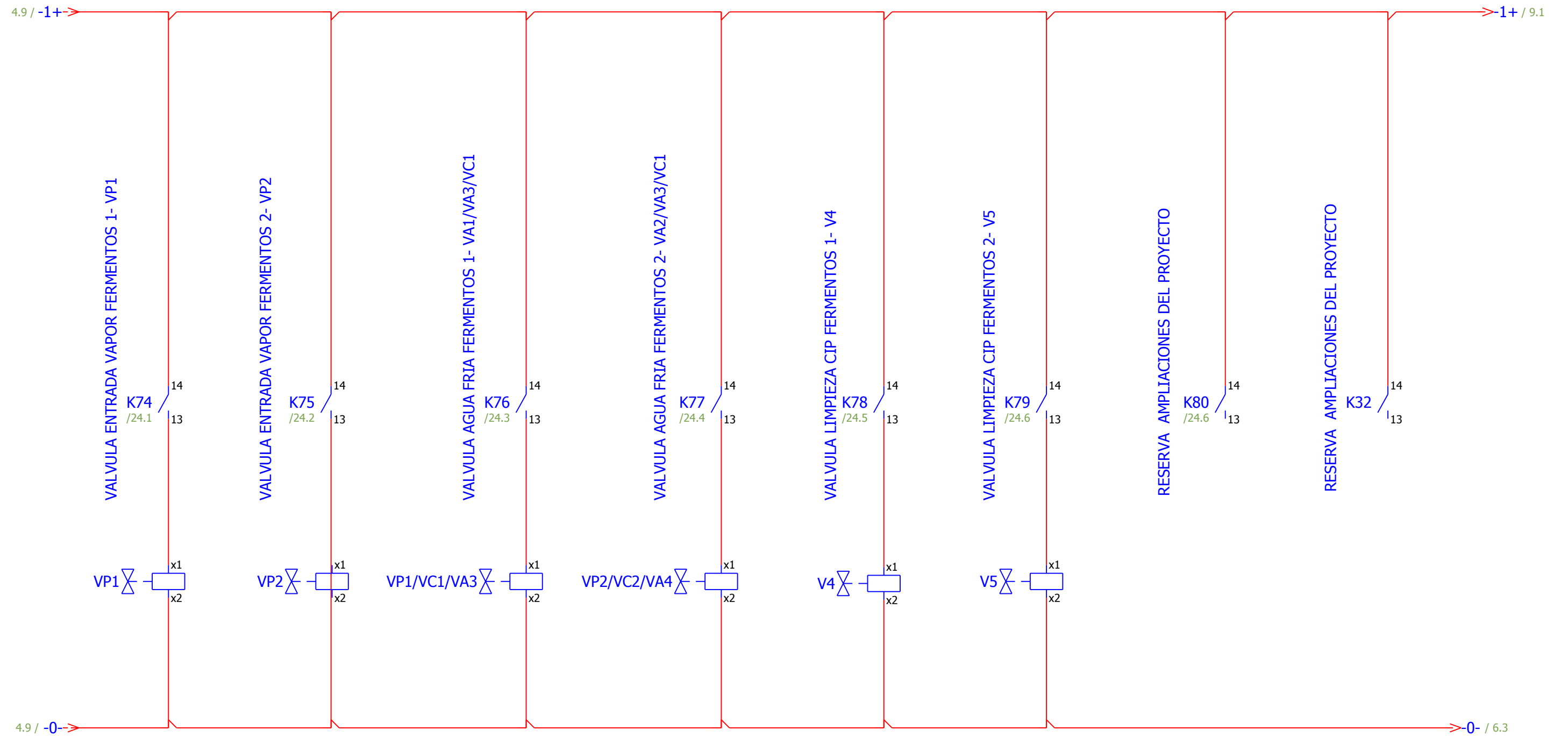

		Date	14/06/2015	Esteban Bacilio		CAPSA FOOD- CENTRAL LECHERA ASTURIANA		Preaccionadores de Equipos de Potencia		= EB3	
		Ed.	Esteban	AUTOMATIZACIÓN DE LINEAS DE PRODUCCIÓN DE YOGURT - TFM		DE YOGURT - TFM				+ ET2	
		Appr		Replaced by		Replaced by		Estandar IEC- 61346		Page	5
Modification	Date	Name	Original	Replaced by		Replaced by				Page	132



# ESTACION REMOTA

FERMENTOS Y SIEMBRA

## SIEMENS IM153-1 PERIFERIA DESCENTRALIZADA

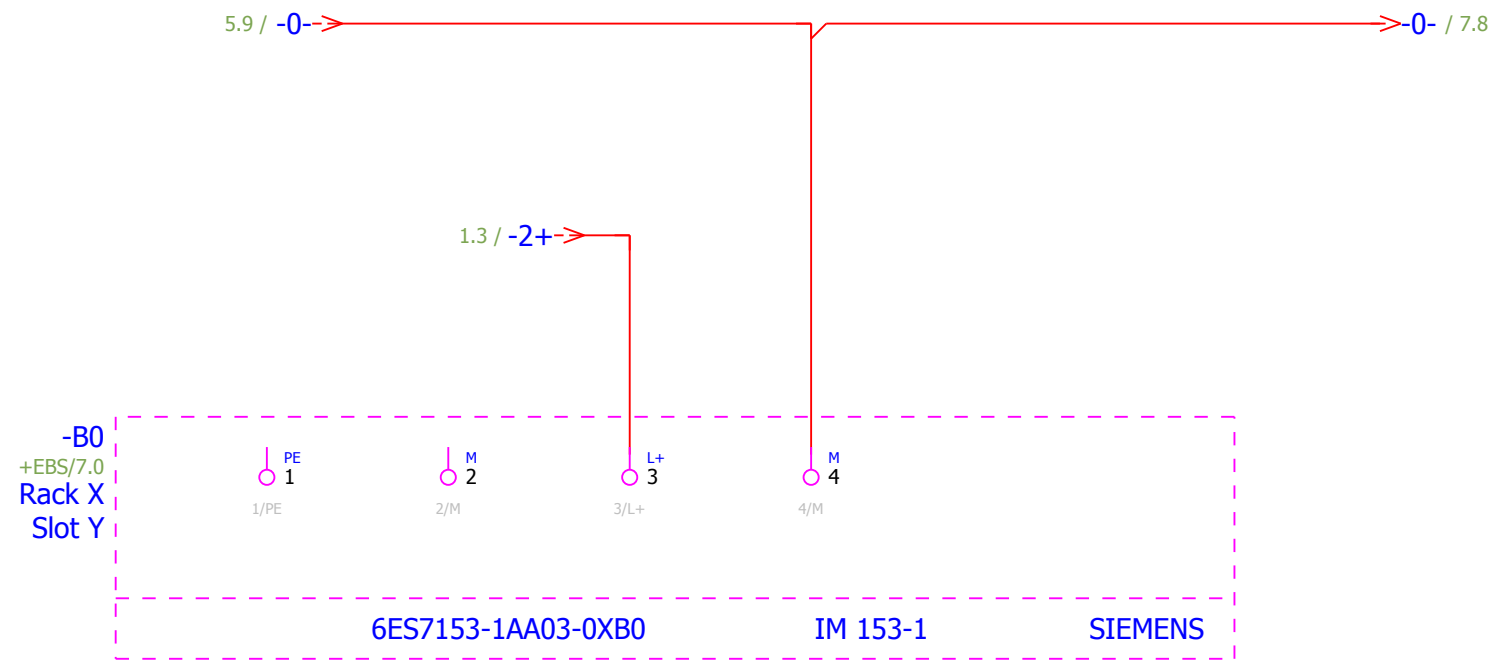

			Date	07/06/2015	Esteban Bacilio	CAPSA FOOD- CENTRAL	Modulo Remoto Siemens ET200M	= EB3
			Ed.	Esteban		LECHERA ASTURIANA		+ ET2
			Appr		AUTOMATIZACIÓN DE LINEAS DE PRODUCCIÓN DE YOGURT - TFM			
Modification	Date	Name	Original	Replaced by	Replaced by			Page 6
							Estandar IEC- 61346	Page 132

# ESTACION REMOTA

FERMENTOS Y SIEMBRA

## SIEMENS MODULO DE ENTRADAS ANALOGICAS

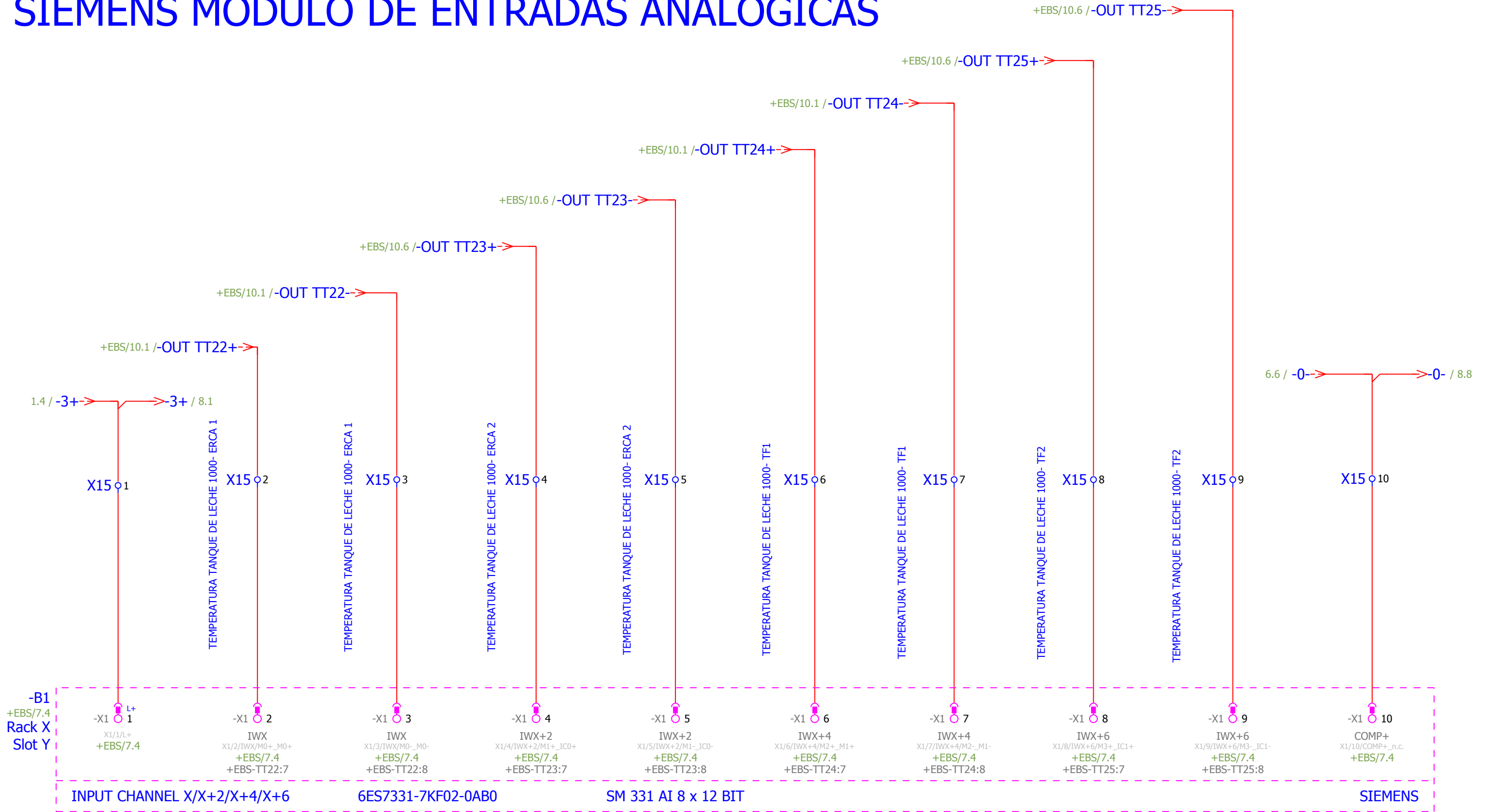

Date	07/06/2015	Esteban Bacilio	CAPSA FOOD- CENTRAL LECHERA ASTURIANA DE YOGURT - TFM	Entradas Analog. Modulo ET200M	= EB3
Ed.	Esteban				+ ET2
Appr		AUTOMATIZACIÓN DE LINEAS DE PRODUCCIÓN DE YOGURT - TFM			
Modification	Date	Name	Original	Replaced by	Replaced by
					Estandar IEC- 61346
					Page 7
					Page 132

# ESTACION REMOTA

FERMENTOS Y SIEMBRA

## SIEMENS MODULO DE ENTRADAS ANALOGICAS

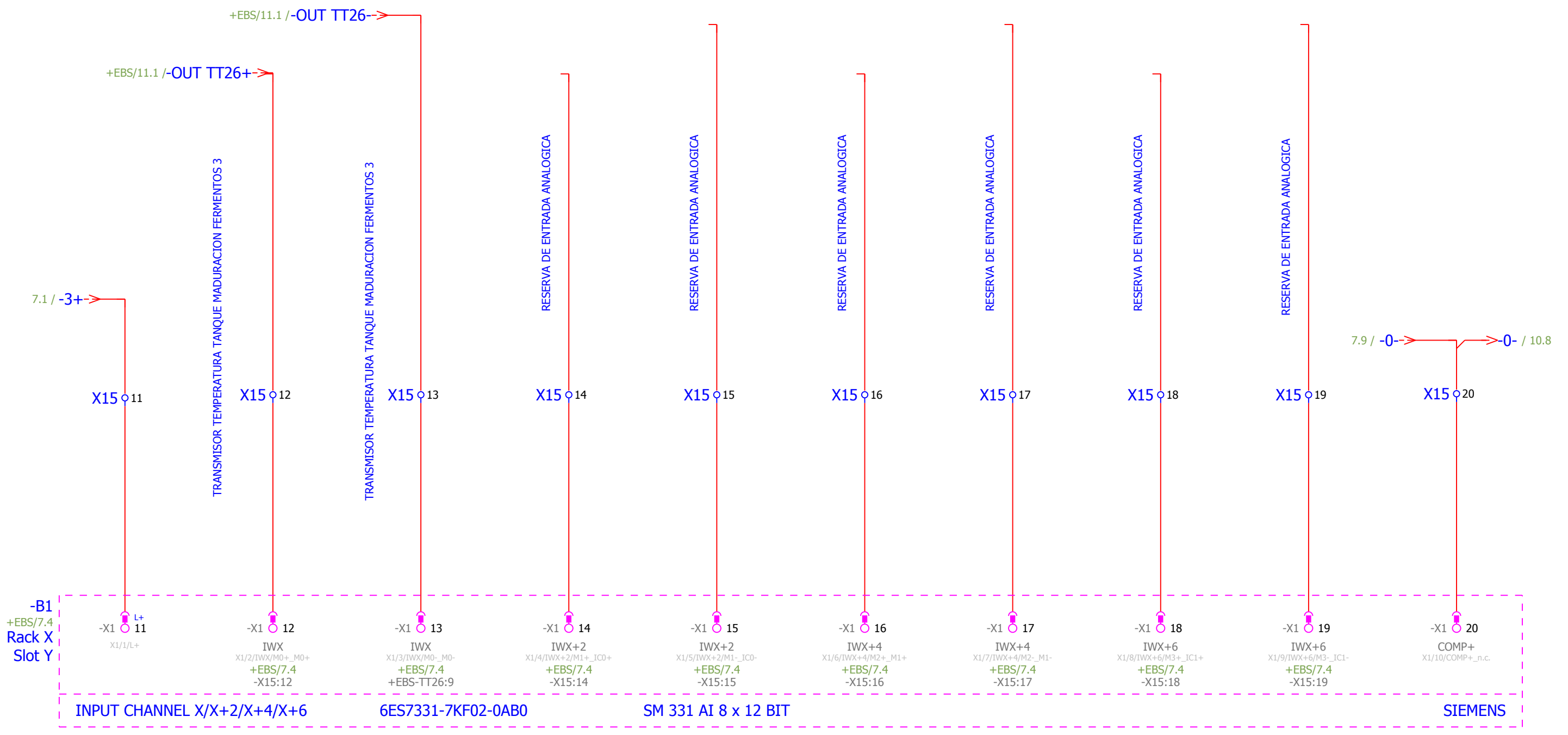

Date	07/06/2015	Esteban Bacilio	CAPSA FOOD- CENTRAL LECHERA ASTURIANA	Entrada Analog. Modulo ET200M	= EB3
Ed.	Esteban		DE YOGURT - TFM		+ ET2
Appr		AUTOMATIZACIÓN DE LINEAS DE PRODUCCIÓN DE YOGURT - TFM			
Modification	Date	Name	Original	Replaced by	Replaced by
					Estandar IEC- 61346
					Page 8
					Page 132

# ESTACION REMOTA

FERMENTOS Y SIEMBRA

## SIEMENS MODULO DE ENTRADAS DIGITALES (B2)

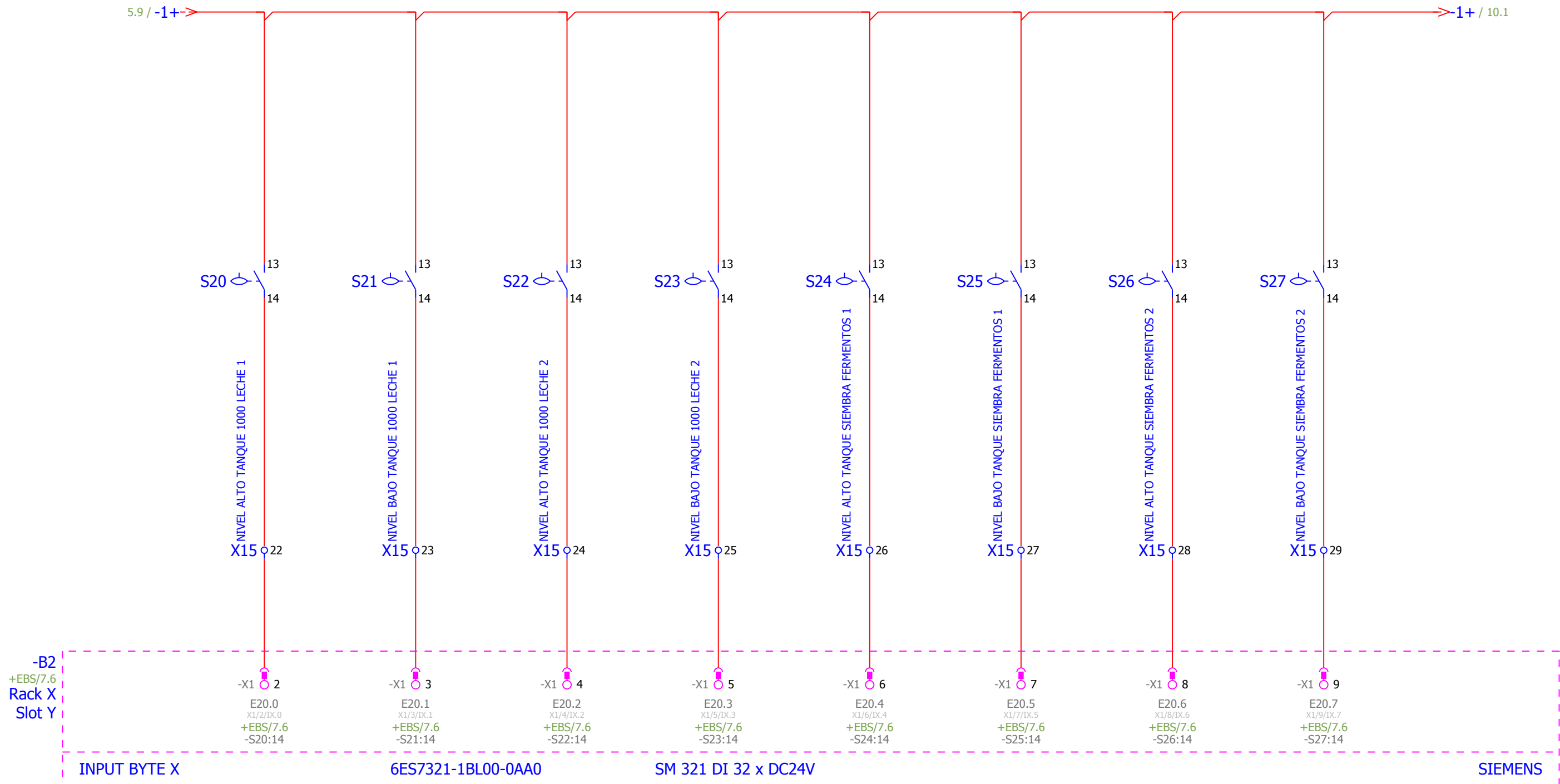

Date	07/06/2015	Esteban Bacilio	CAPSA FOOD- CENTRAL LECHERA ASTURIANA DE YOGURT - TFM	Entradas Digitales (B2) Modulo ET200M	= EB3 + ET2
Ed.	Esteban				
Appr		AUTOMATIZACIÓN DE LINEAS DE PRODUCCIÓN DE YOGURT			
Modification	Date	Name	Original	Replaced by	Replaced by
					Estandar IEC- 61346
					Page 9
					Page 132

# ESTACION REMOTA

FERMENTOS Y SIEMBRA

## SIEMENS MODULO DE ENTRADAS DIGITALES (B2)

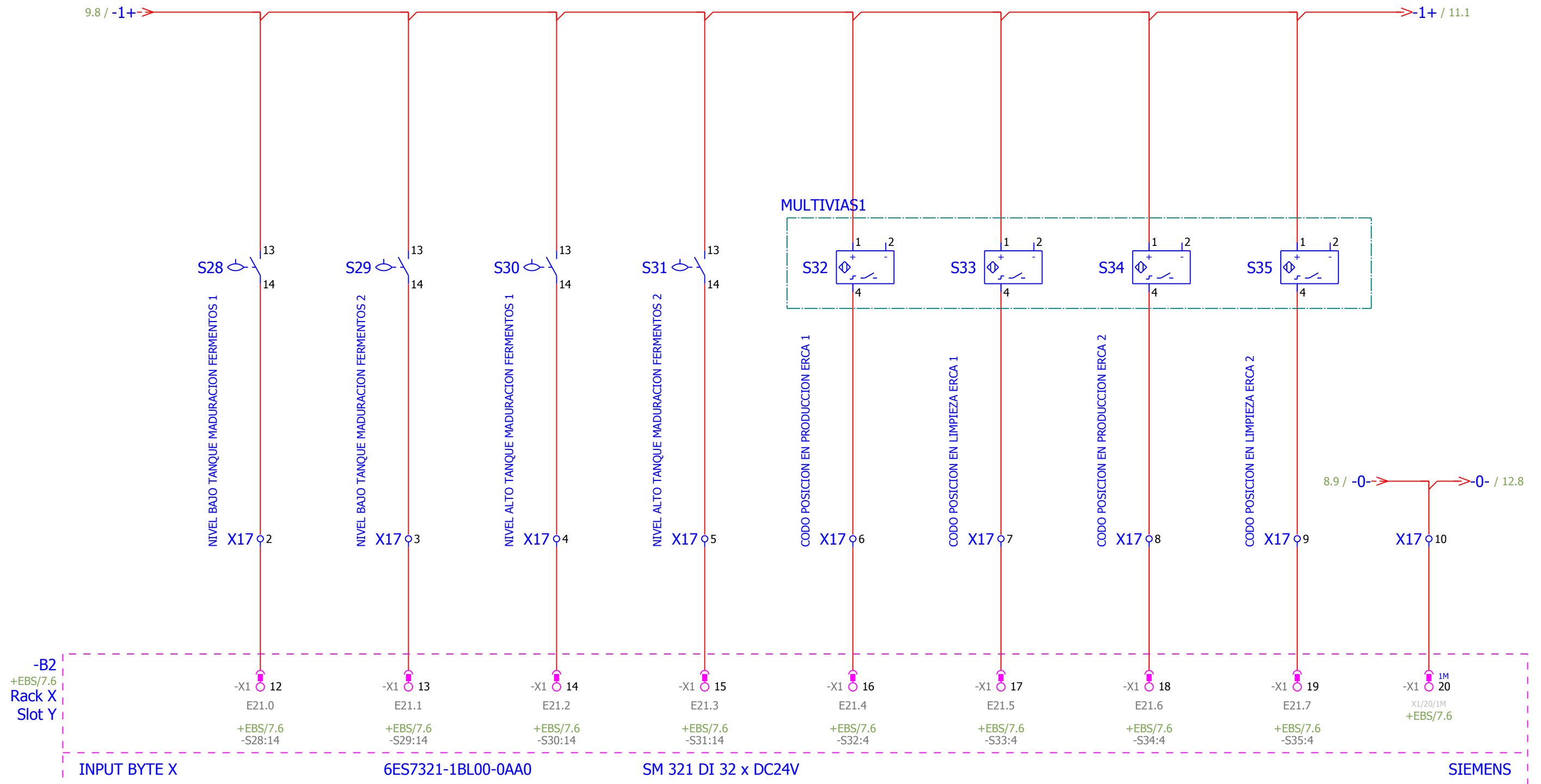

Date	07/06/2015	Esteban Bacilio	CAPSA FOOD- CENTRAL LECHERA ASTURIANA	Entradas Digitales (B2) Modulo ET200M	= EB3
Ed.	Esteban		DE YOGURT - TFM		+ ET2
Appr					
Modification	Date	Name	Original	Replaced by	Replaced by
					Estandar IEC- 61346
					Page 10
					Page 132





# ESTACION REMOTA

FERMENTOS Y SIEMBRA

## SIEMENS MODULO DE ENTRADAS DIGITALES (B3)

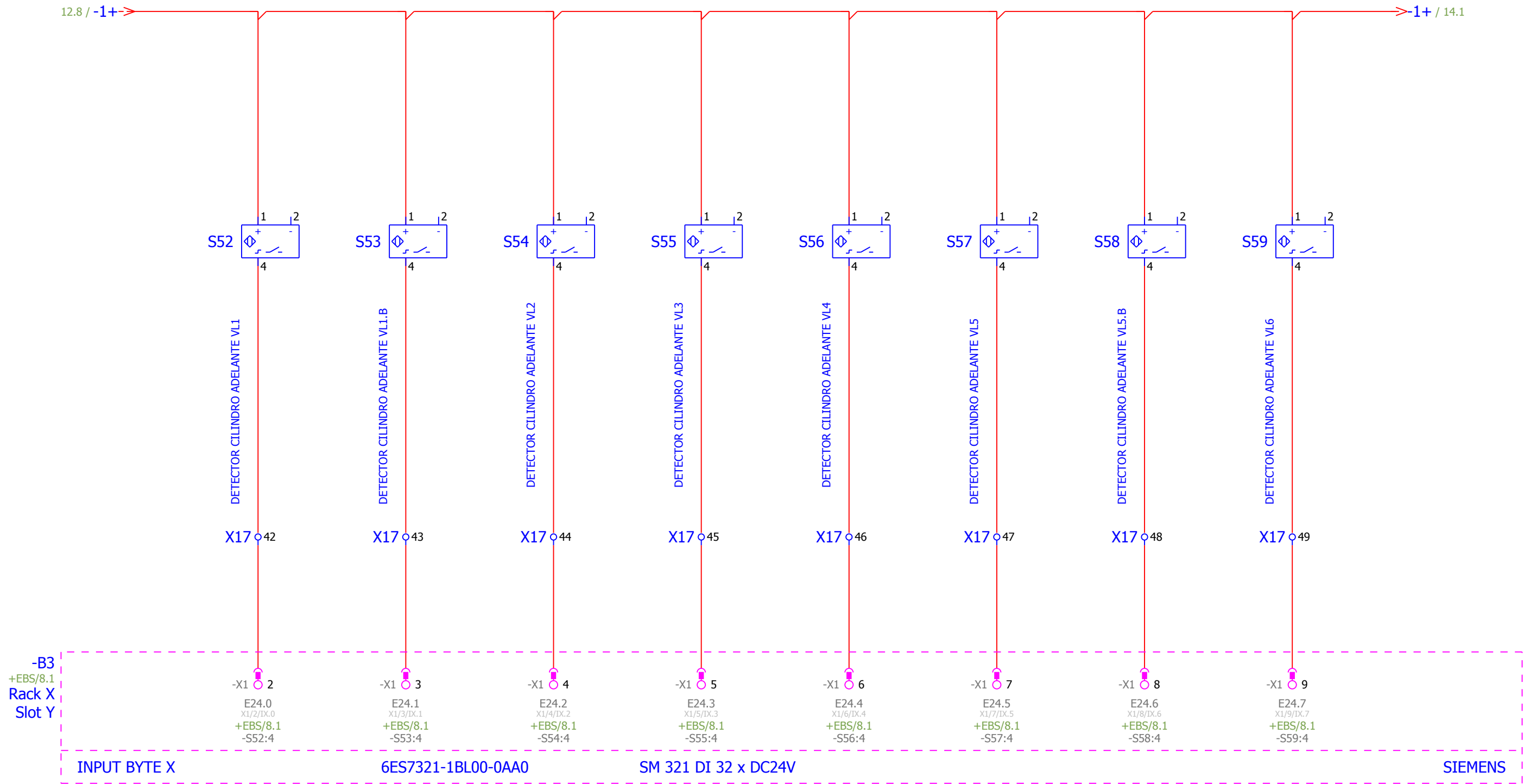

Date	14/06/2015	Esteban Bacilio	CAPSA FOOD- CENTRAL LECHERA ASTURIANA DE YOGURT - TFM	Entradas Digitales Modulo (B3) ET200M	= EB3 + ET2
Ed.	Esteban				
Appr					
Modification	Date	Name	Original	Replaced by	Replaced by
					Estandar IEC- 61346
					Page 13
					Page 132





# ESTACION REMOTA

FERMENTOS Y SIEMBRA

## SIEMENS MODULO DE ENTRADAS DIGITALES (B3)

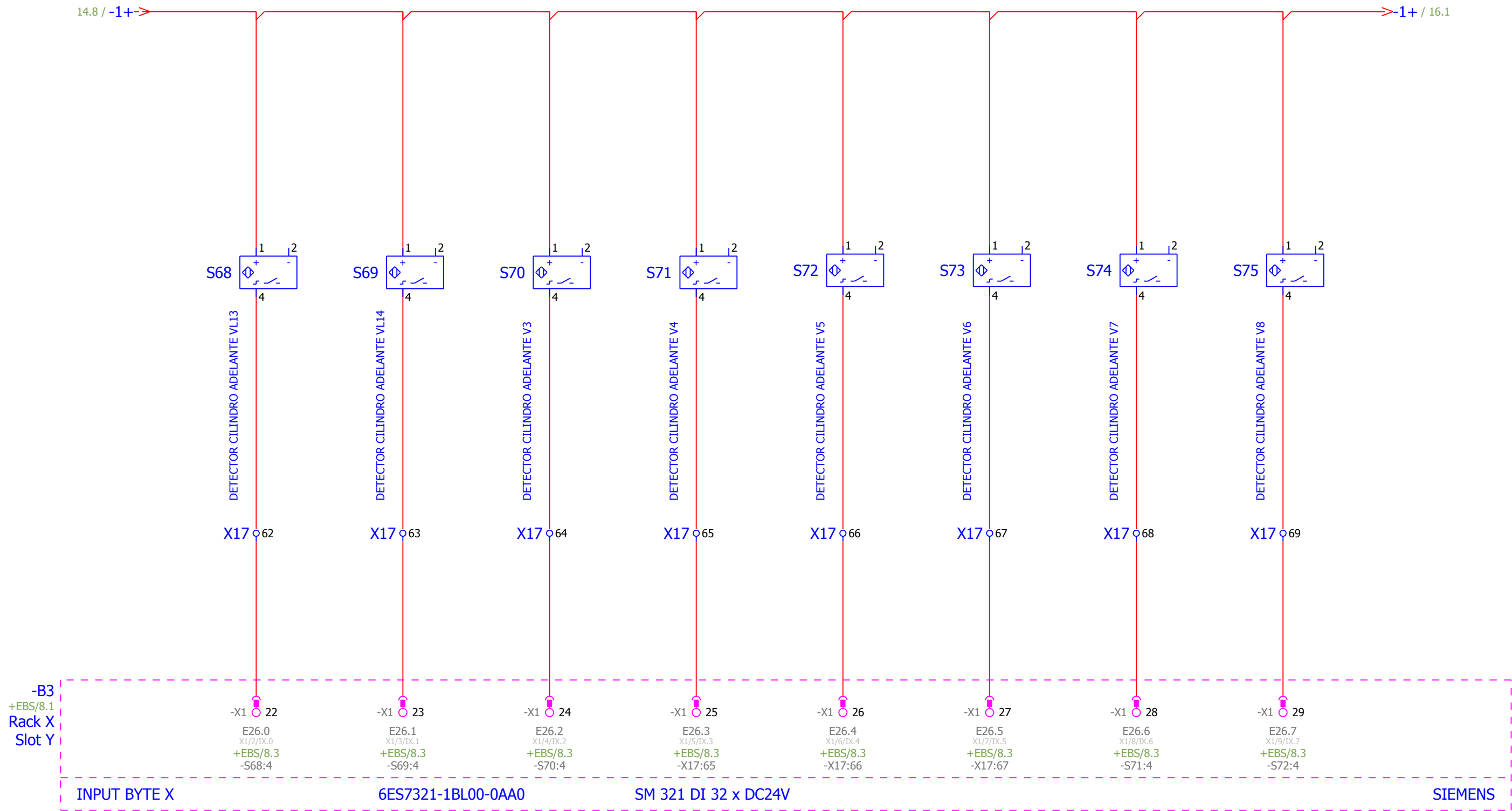

Date	14/06/2015	Esteban Bacilio	CAPSA FOOD- CENTRAL LECHERA ASTURIANA	Entradas Digitales Modulo (B3) ET200M	= EB3
Ed.	Esteban		DE YOGURT - TFM		+ ET2
Appr		AUTOMATIZACIÓN DE LINEAS DE PRODUCCIÓN DE YOGURT - TFM			
Modification	Date	Name	Original	Replaced by	Replaced by
					Estandar IEC- 61346
					Page 15
					Page 132

# ESTACION REMOTA

## SIEMENS MODULO DE ENTRADAS DIGITALES (B3)

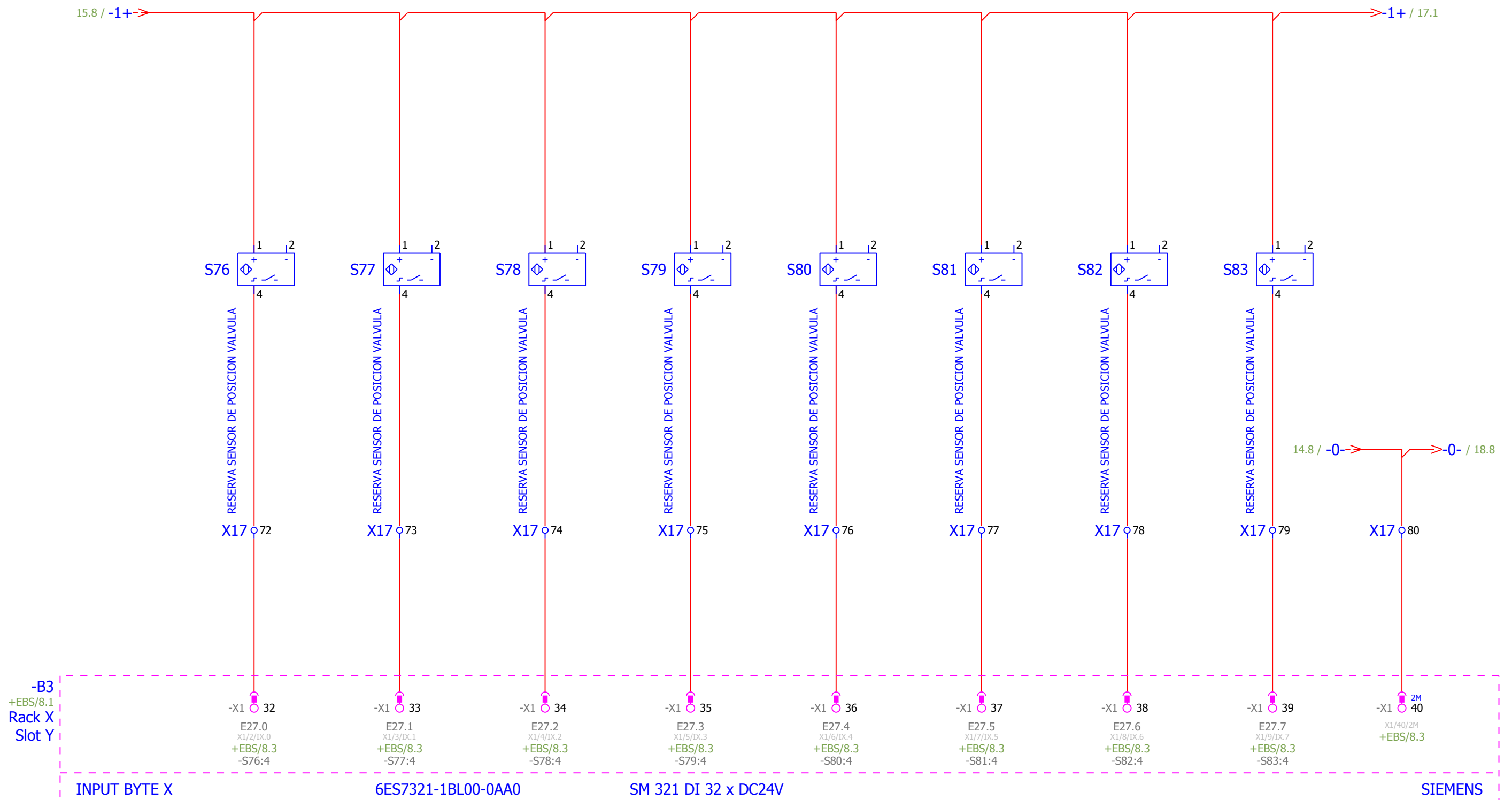

Date	14/06/2015	Esteban Bacilio	CAPSA FOOD- CENTRAL LECHERA ASTURIANA	Entradas Digitales Modulo (B3) ET200M	= EB3
Ed.	Esteban		DE YOGURT - TFM		+ ET2
Appr					
Modification	Date	Name	Original	Replaced by	Replaced by
					Estandar IEC- 61346
					Page 16
					Page 132

# ESTACION REMOTA

## SIEMENS MODULO DE ENTRADAS DIGITALES (B4)

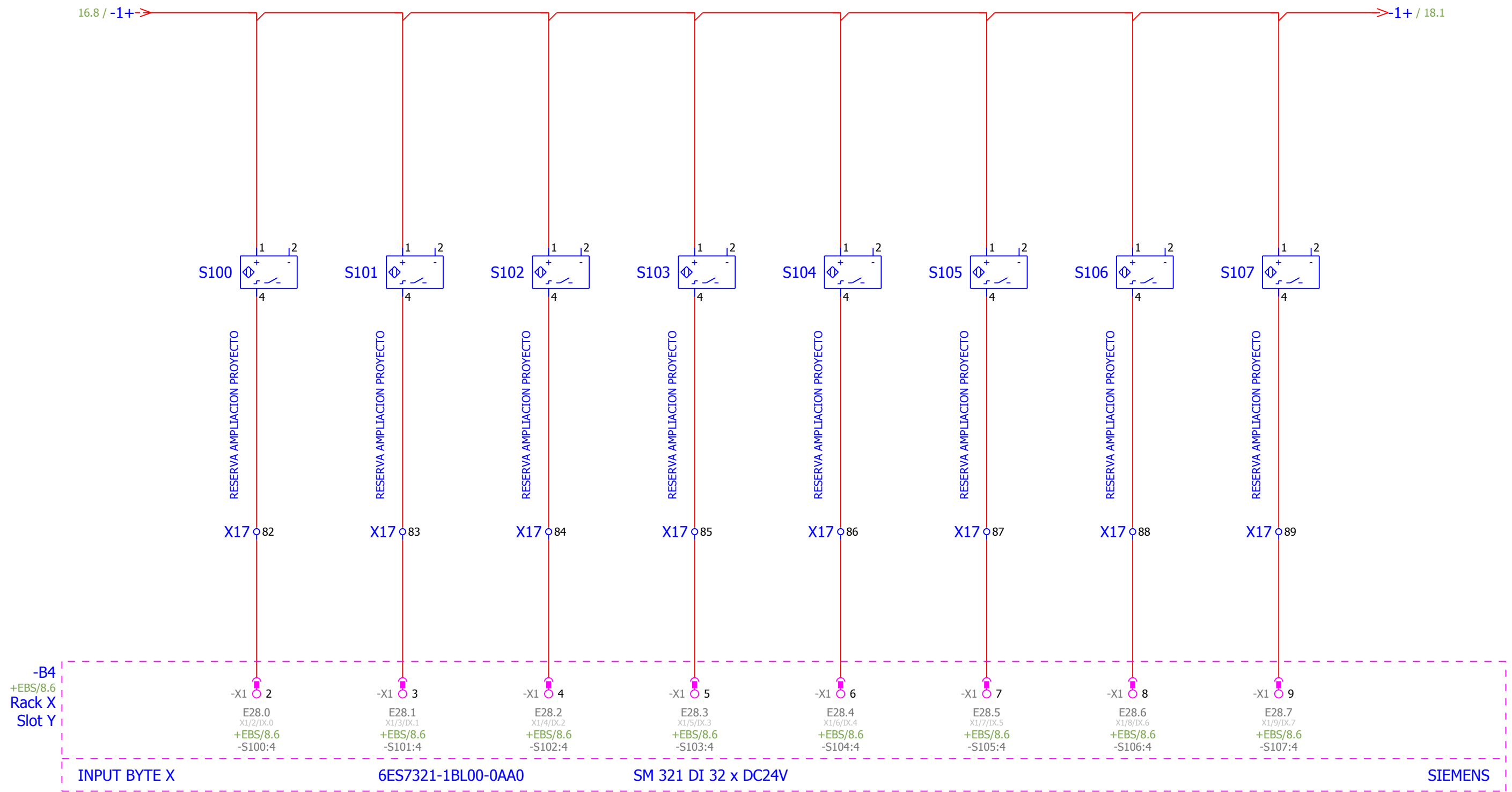

Date	14/06/2015	Esteban Bacilio	CAPSA FOOD- CENTRAL LECHERA ASTURIANA	Entradas Digitales Modulo (B4) ET200M	= EB3
Ed.	Esteban		DE YOGURT - TFM		+ ET2
Appr		AUTOMATIZACIÓN DE LINEAS DE PRODUCCIÓN			
Modification	Date	Name	Original	Replaced by	Replaced by
					Estandar IEC- 61346
					Page 17
					Page 132

# ESTACION REMOTA

FERMENTOS Y SIEMBRA

## SIEMENS MODULO DE ENTRADAS DIGITALES (B4)

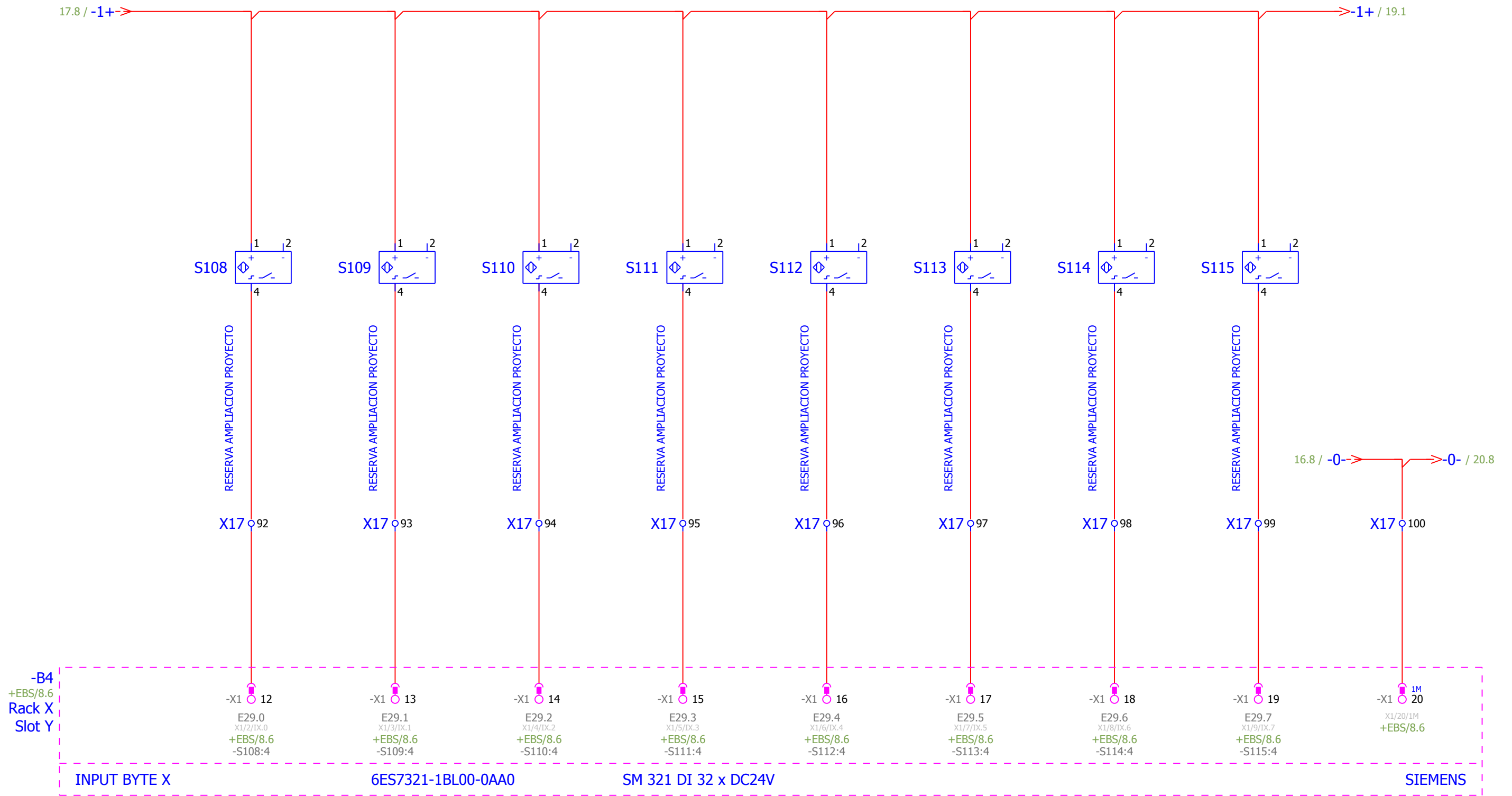

Date	14/06/2015	Esteban Bacilio	CAPSA FOOD- CENTRAL LECHERA ASTURIANA	Entradas Digitales Modulo (B4) ET200M	= EB3
Ed.	Esteban		DE YOGURT - TFM		+ ET2
Appr		AUTOMATIZACIÓN DE LINEAS DE PRODUCCIÓN			
Modification	Date	Name	Original	Replaced by	Replaced by
					Estandar IEC- 61346
					Page 18
					Page 132



# ESTACION REMOTA

FERMENTOS Y SIEMBRA

## SIEMENS MODULO DE ENTRADAS DIGITALES (B4)

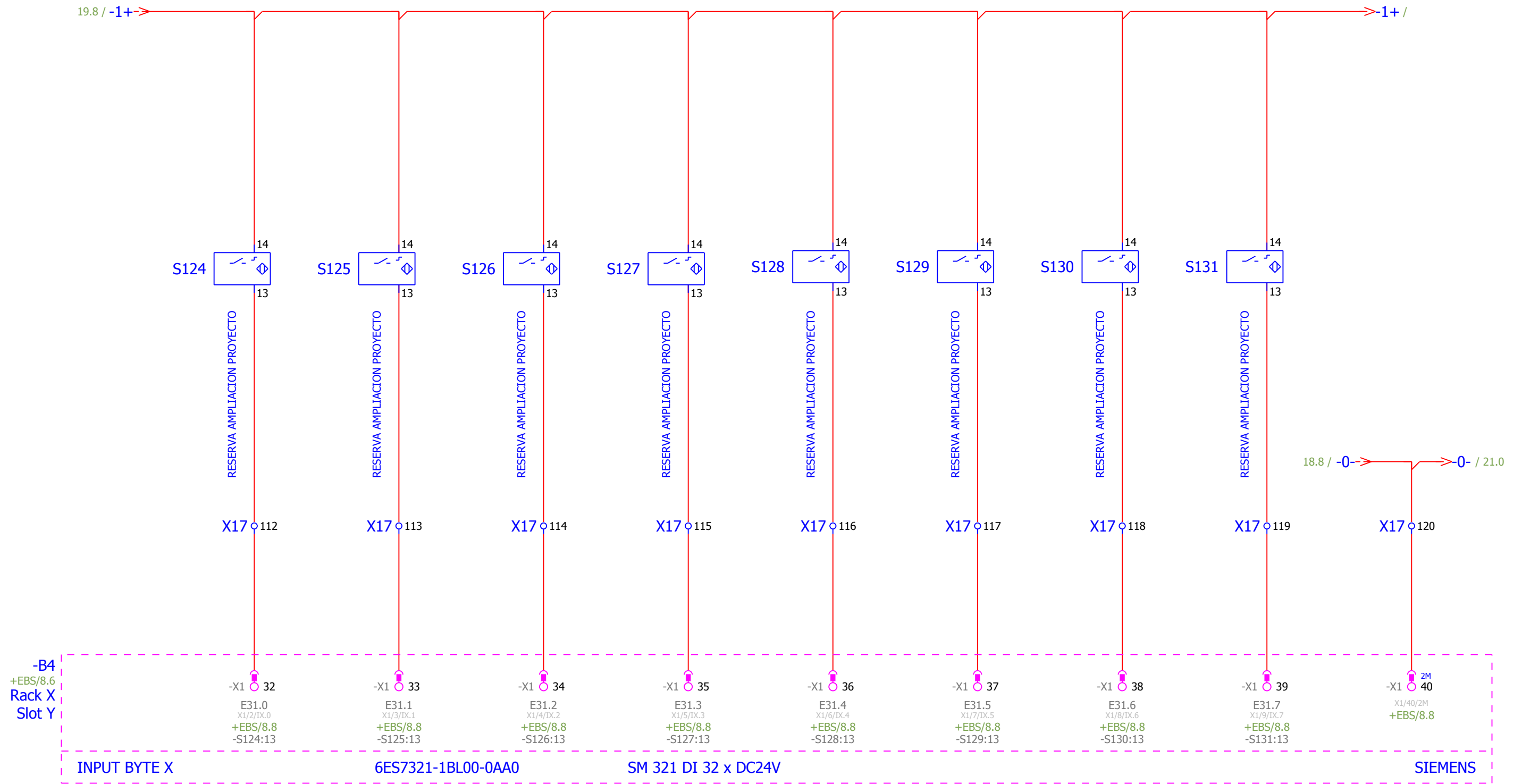

Date	14/06/2015	Esteban Bacilio	CAPSA FOOD- CENTRAL LECHERA ASTURIANA	Entradas Digitales Modulo (B4) ET200M	= EB3
Ed.	Esteban		DE YOGURT - TFM		+ ET2
Appr		AUTOMATIZACIÓN DE LINEAS DE PRODUCCIÓN DE YOGURT - TFM			
Modification	Date	Name	Original	Replaced by	Replaced by
					Estándar IEC- 61346
					Page 20
					Page 132

# ESTACION REMOTA

FERMENTOS Y SIEMBRA

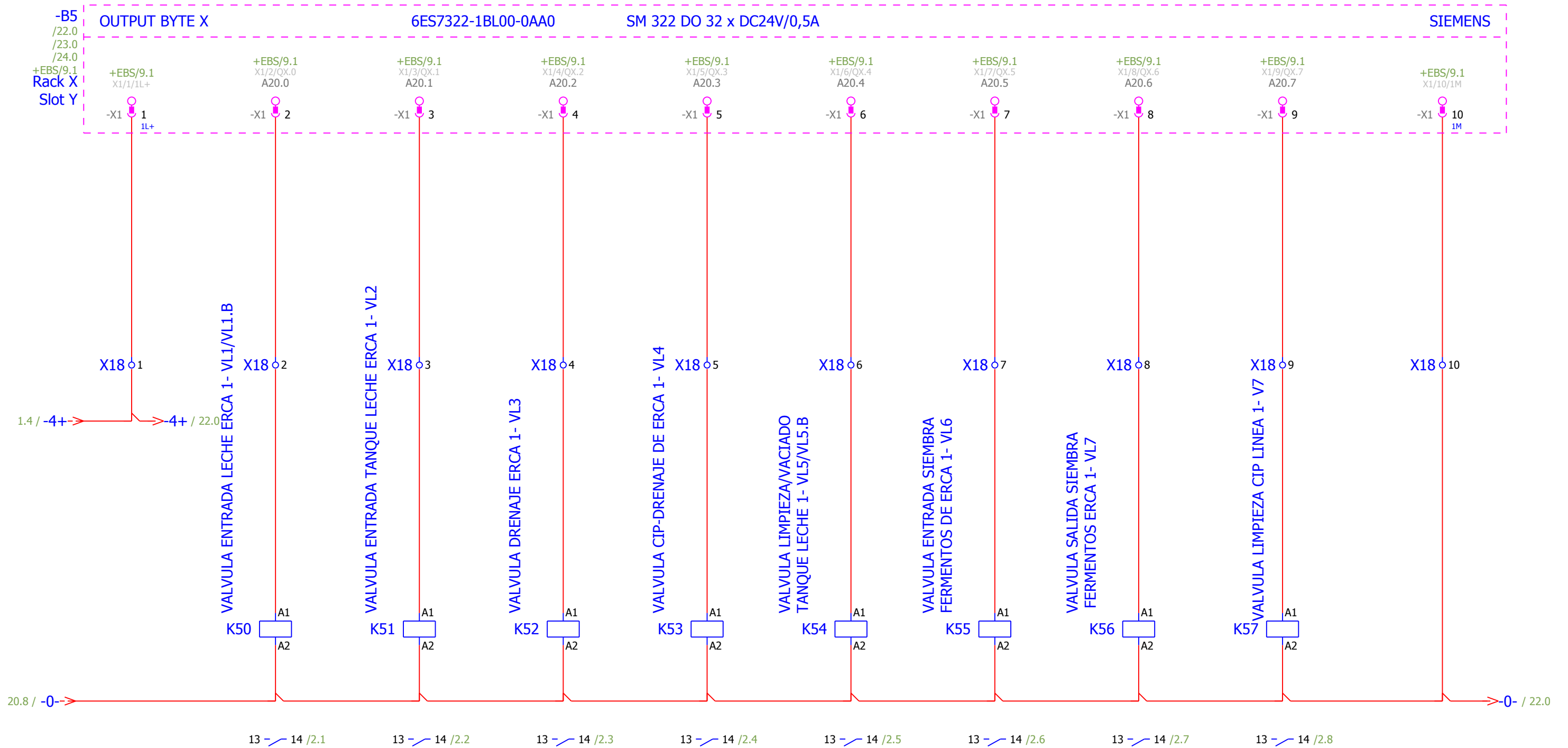

## SIEMENS MODULO DE SALIDAS DIGITALES (B5)

Date	07/06/2015	Esteban Bacilio	CAPSA FOOD- CENTRAL LECHERA ASTURIANA DE YOGURT - TFM	Salidas Digitales Modulo (B5) ET200M	= EB3
Ed.	Esteban				+ ET2
Appr		AUTOMATIZACIÓN DE LINEAS DE PRODUCCIÓN DE YOGURT			
Modification	Date	Name	Original	Replaced by	Replaced by
					Estandar IEC- 61346
					Page 21
					Page 132



# ESTACION REMOTA

FERMENTOS Y SIEMBRA

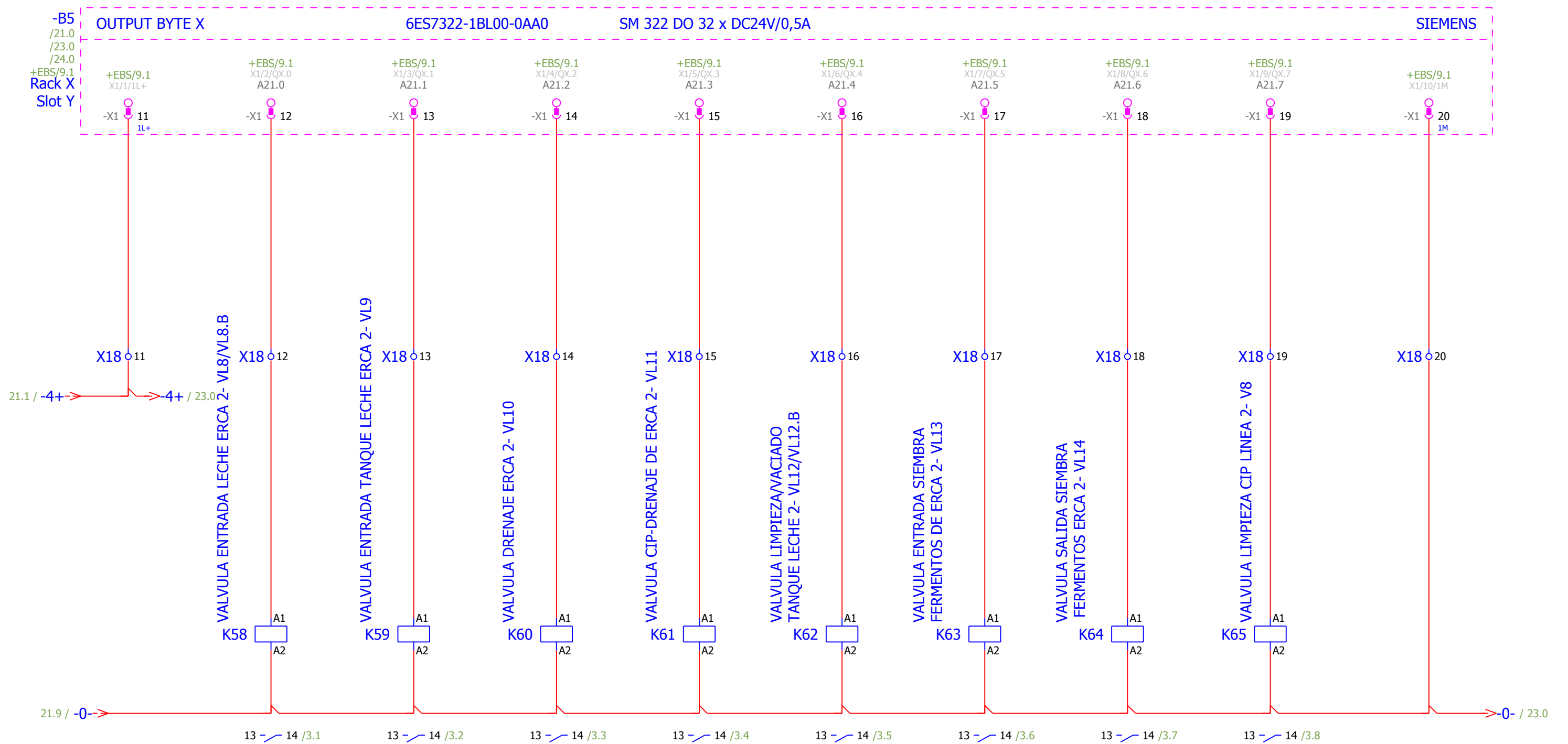

## SIEMENS MODULO DE SALIDAS DIGITALES (B5)

Date	07/06/2015	Esteban Bacilio	CAPSA FOOD- CENTRAL LECHERA ASTURIANA DE YOGURT - TFM	Salidas Digitales Modulo (B5) ET200M	= EB3 + ET2
Ed.	Esteban				
Appr		AUTOMATIZACIÓN DE LINEAS DE PRODUCCIÓN DE YOGURT			
Modification	Date	Name	Original	Replaced by	Replaced by
					Estandar IEC- 61346
					Page 22
					Page 132

# ESTACION REMOTA

FERMENTOS Y SIEMBRA

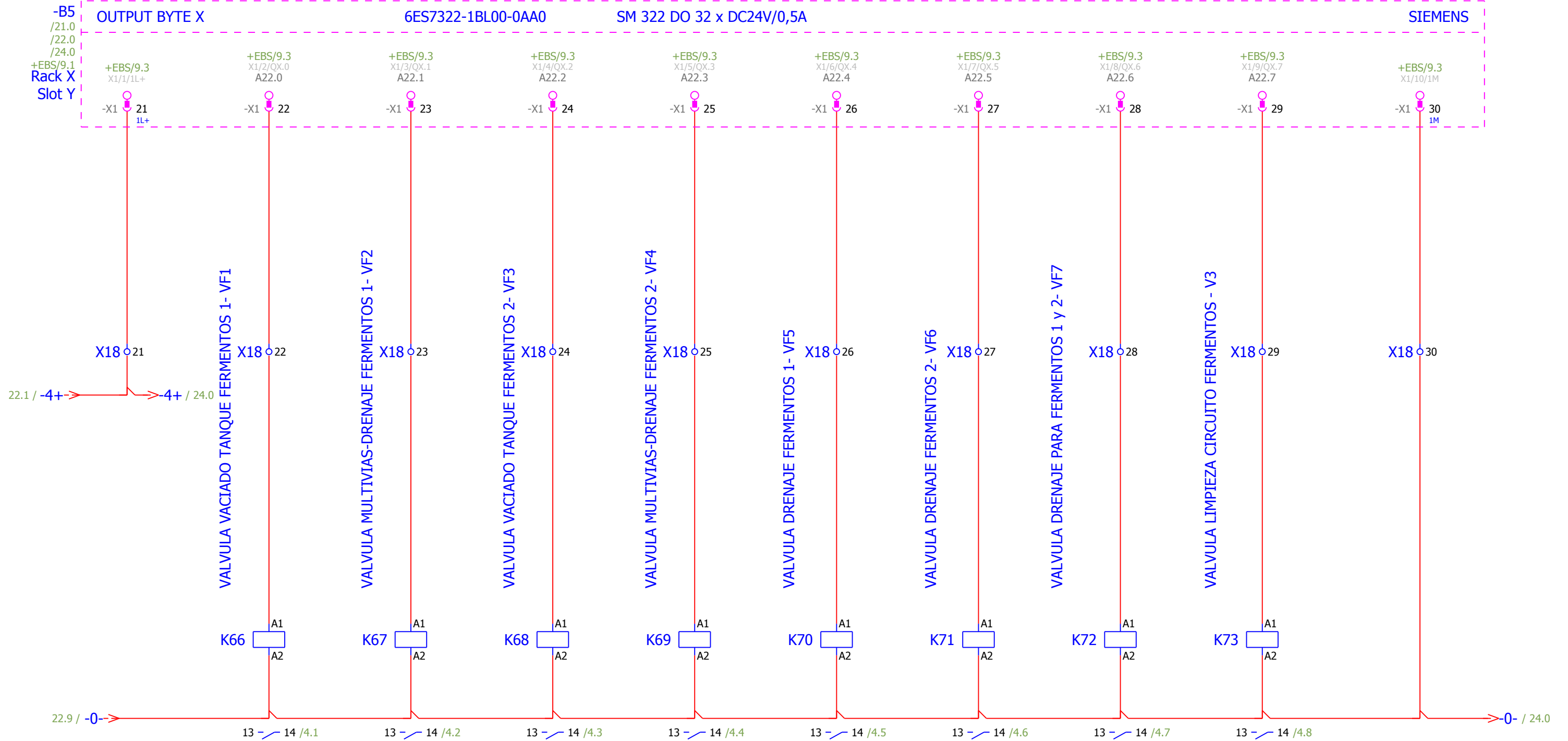

## SIEMENS MODULO DE SALIDAS DIGITALES (B5)

Date	07/06/2015	Esteban Bacilio	CAPSA FOOD- CENTRAL LECHERA ASTURIANA	Salidas Digitales Modulo (B5) ET200M	= EB3
Ed.	Esteban		DE YOGURT - TFM		+ ET2
Appr		AUTOMATIZACIÓN DE LINEAS DE PRODUCCIÓN			
Modification	Date	Name	Original	Replaced by	Replaced by
					Estandar IEC- 61346
					Page 23
					Page 132

# ESTACION REMOTA

FERMENTOS Y SIEMBRA

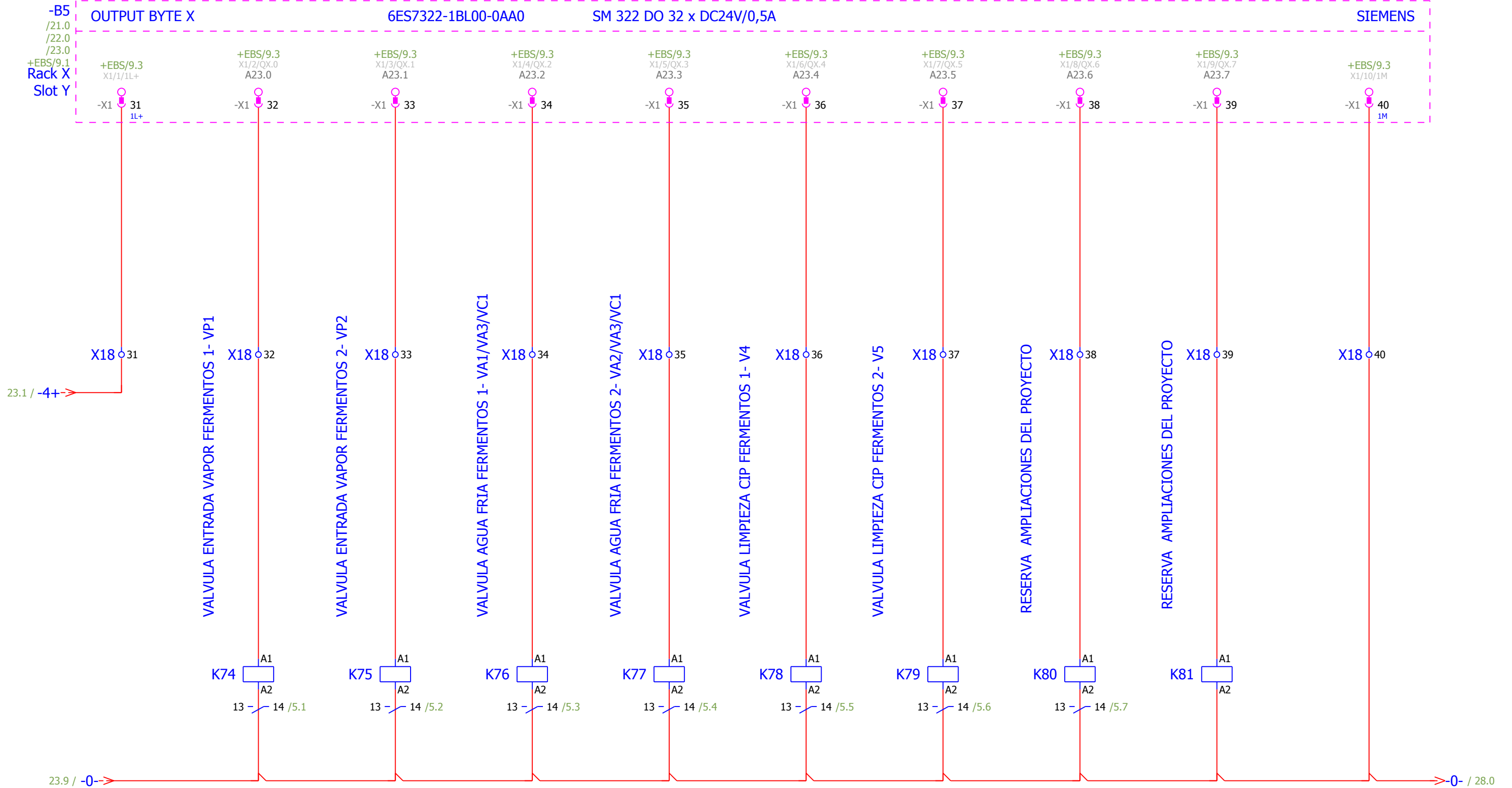

## SIEMENS MODULO DE SALIDAS DIGITALES (B5)

Date	07/06/2015	Esteban Bacilio	CAPSA FOOD- CENTRAL LECHERA ASTURIANA	Salidas Digitales Modulo (B5) ET200M	= EB3
Ed.	Esteban		DE YOGURT - TFM		+ ET2
Appr		AUTOMATIZACIÓN DE LINEAS DE PRODUCCIÓN			
Modification	Date	Name	Original	Replaced by	Replaced by
					Estandar IEC- 61346
					Page 24
					Page 132

# ESTACION REMOTA

FERMENTOS Y SIEMBRA

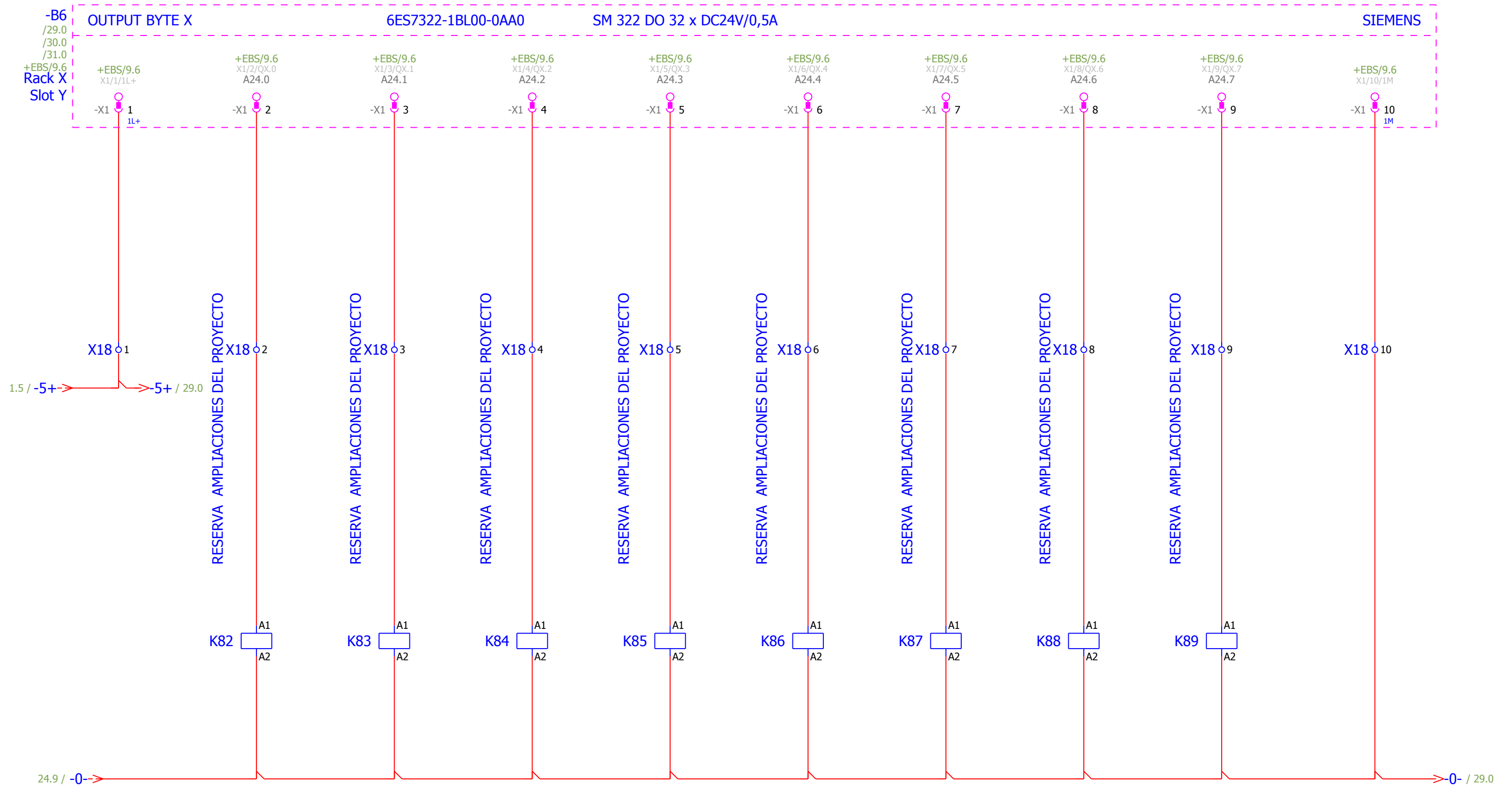

## SIEMENS MODULO DE SALIDAS DIGITALES (B6)

Date	07/06/2015	Esteban Bacilio	CAPSA FOOD- CENTRAL LECHERA ASTURIANA	Salidas Digitales Modulo (B6) ET200M	= EB3
Ed.	Esteban		DE YOGURT - TFM		+ ET2
Appr		AUTOMATIZACIÓN DE LINEAS DE PRODUCCIÓN			
Modification	Date	Name	Original	Replaced by	Replaced by
					Estandar IEC- 61346
					Page 28
					Page 132

# ESTACION REMOTA

FERMENTOS Y SIEMBRA

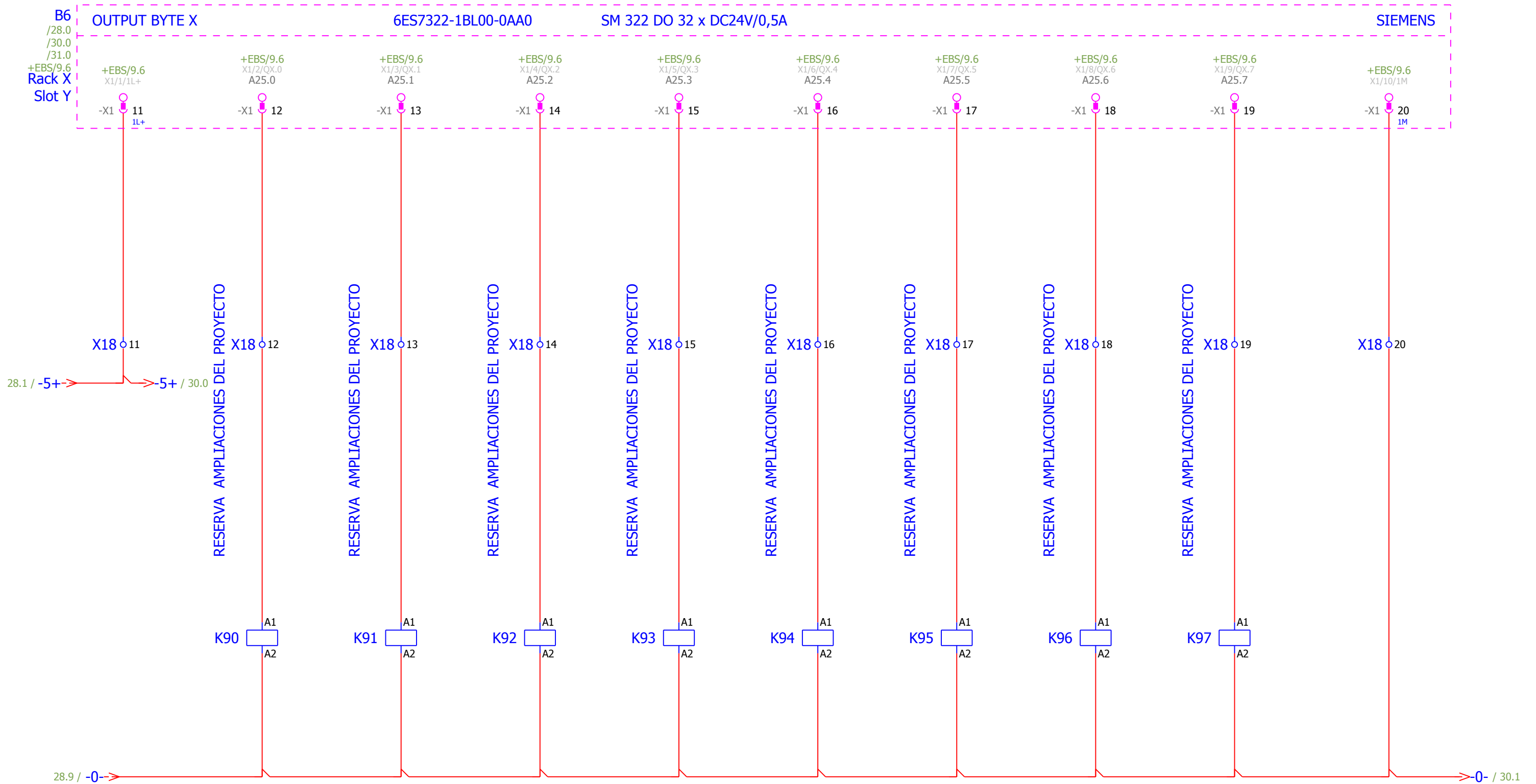

## SIEMENS MODULO DE SALIDAS DIGITALES (B6)

Date	07/06/2015	Esteban Bacilio	CAPSA FOOD- CENTRAL LECHERA ASTURIANA	Salidas Digitales Modulo (B6) ET200M	= EB3
Ed.	Esteban		DE YOGURT - TFM		+ ET2
Appr		AUTOMATIZACIÓN DE LINEAS DE PRODUCCIÓN			
Modification	Date	Name	Original	Replaced by	Replaced by
					Estándar IEC- 61346
					Page 29
					Page 132

# ESTACION REMOTA

FERMENTOS Y SIEMBRA

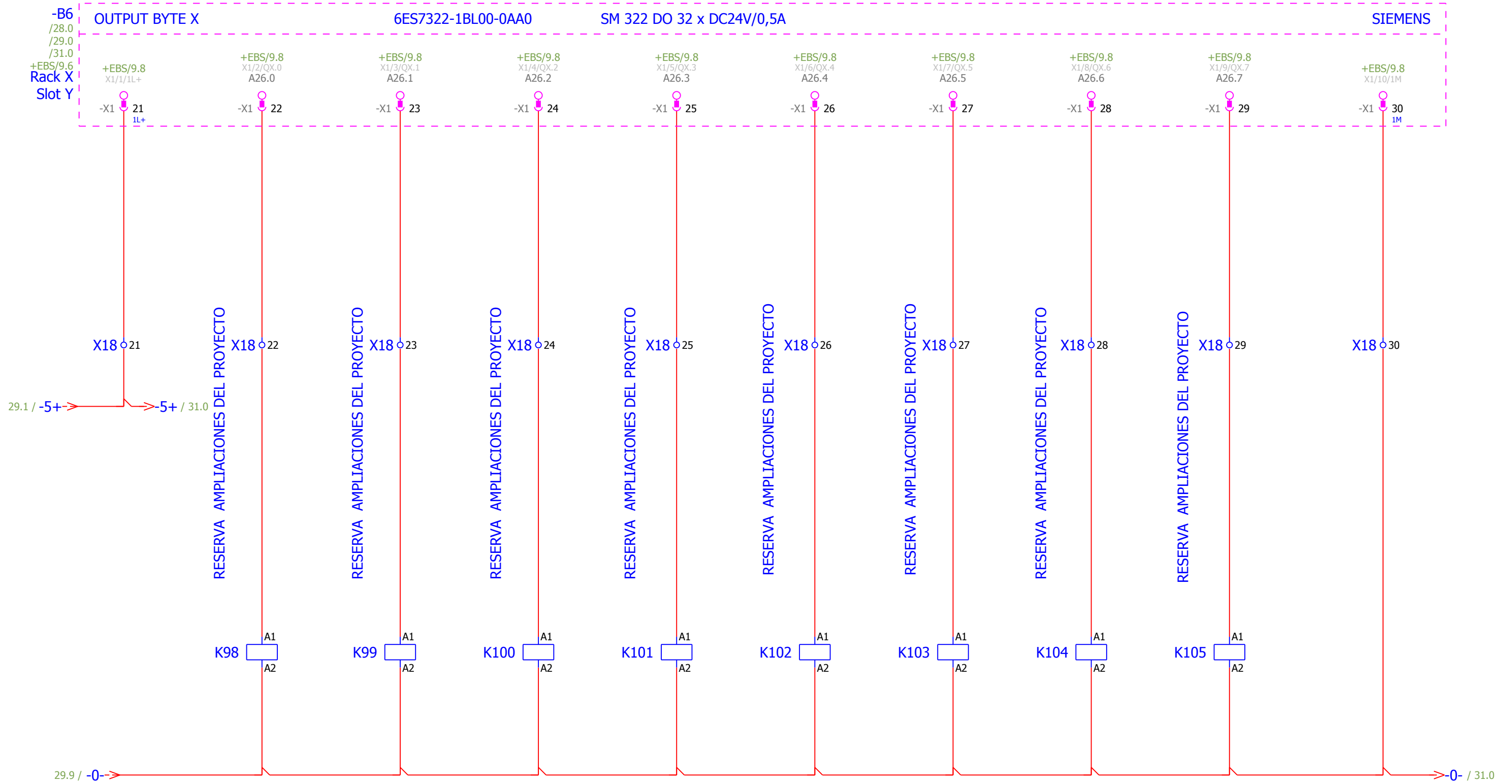

## SIEMENS MODULO DE SALIDAS DIGITALES (B6)

Date	07/06/2015	Esteban Bacilio	CAPSA FOOD- CENTRAL LECHERA ASTURIANA	Salidas Digitales Modulo (B6) ET200M	= EB3
Ed.	Esteban		DE YOGURT - TFM		+ ET2
Appr		AUTOMATIZACIÓN DE LINEAS DE PRODUCCIÓN			
Original		Replaced by	Replaced by		Estandar IEC- 61346
Modification	Date	Name			Page 30
					Page 132

# ESTACION REMOTA

FERMENTOS Y SIEMBRA

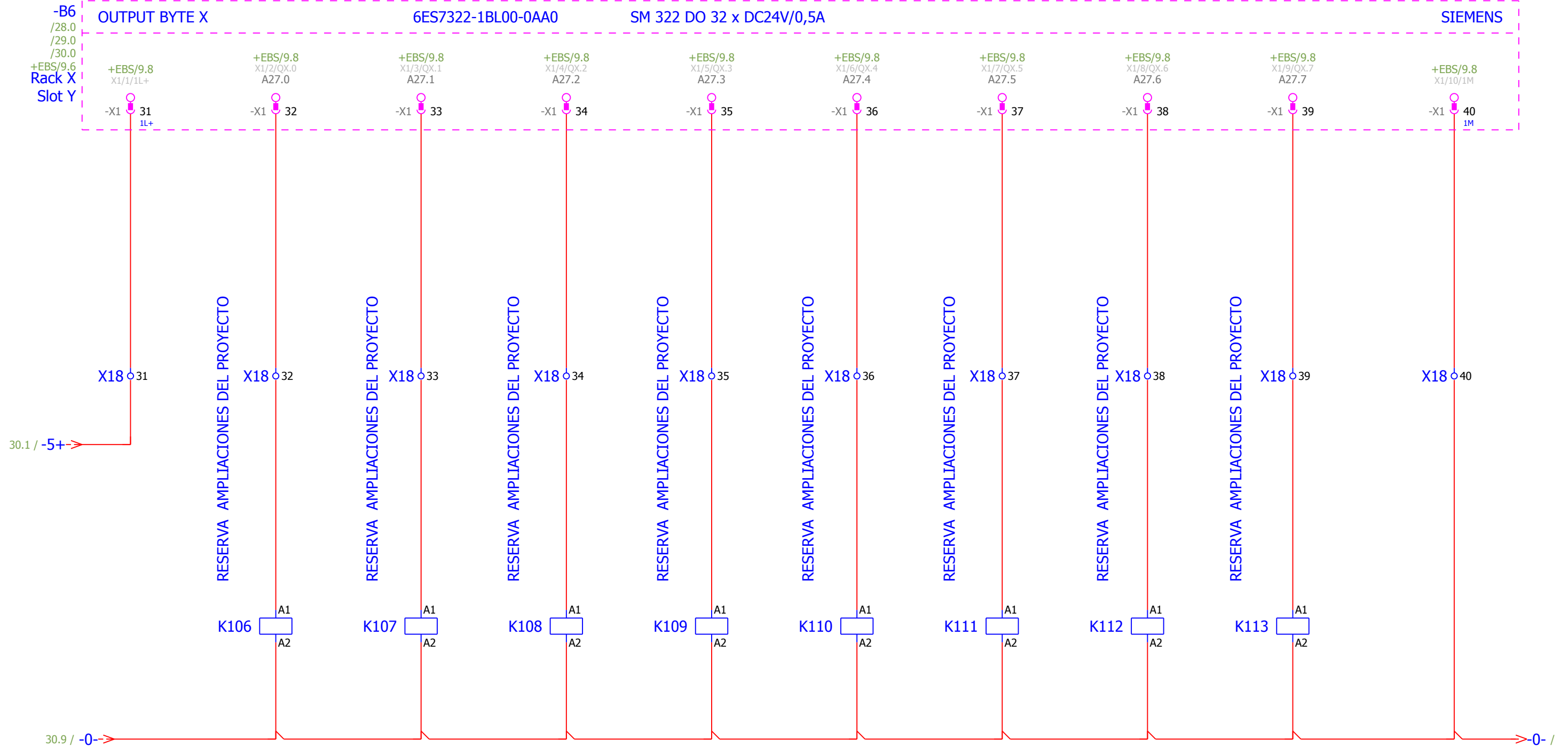

## SIEMENS MODULO DE SALIDAS DIGITALES (B6)

Date	07/06/2015	Esteban Bacilio	CAPSA FOOD- CENTRAL LECHERA ASTURIANA	Salidas Digitales Modulo (B6) ET200M	= EB3
Ed.	Esteban		DE YOGURT - TFM		+ ET2
Appr		AUTOMATIZACIÓN DE LINEAS DE PRODUCCIÓN			
Modification	Date	Name	Original	Replaced by	Replaced by
					Estandar IEC- 61346
					Page 31
					Page 132

IT

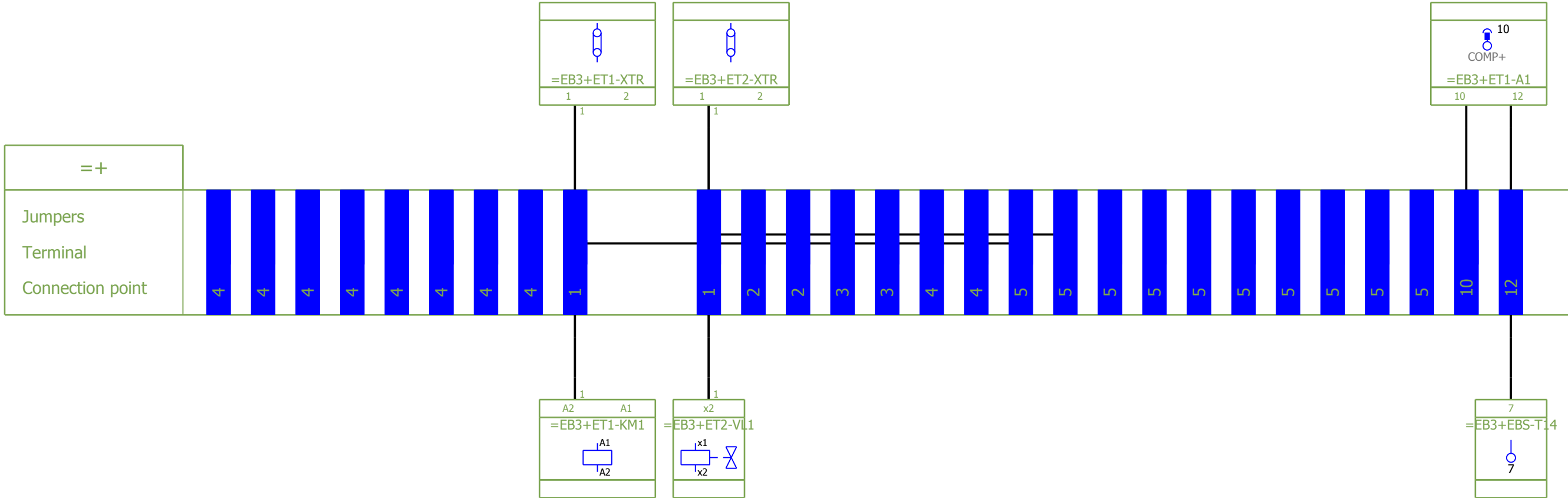

External targets



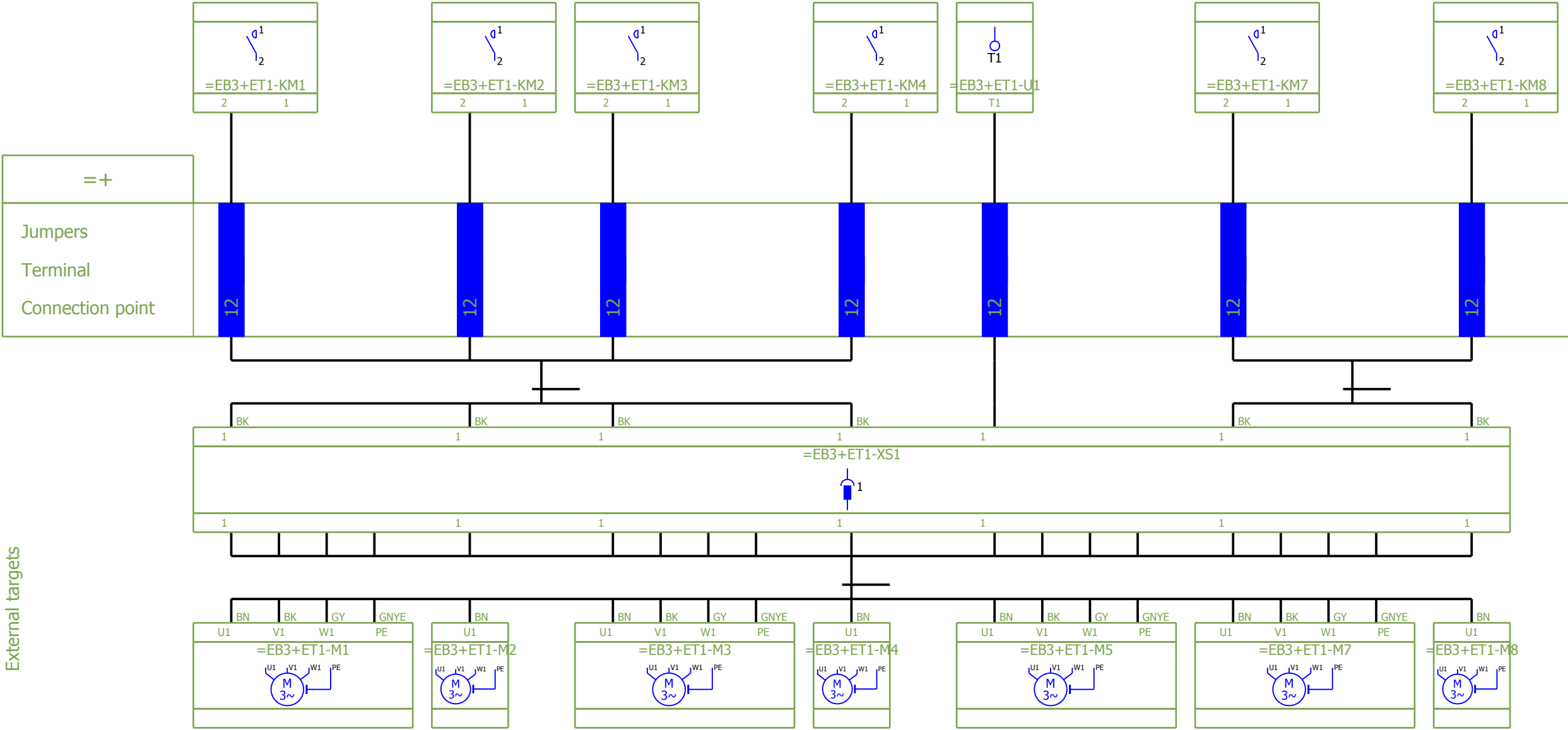

External targets

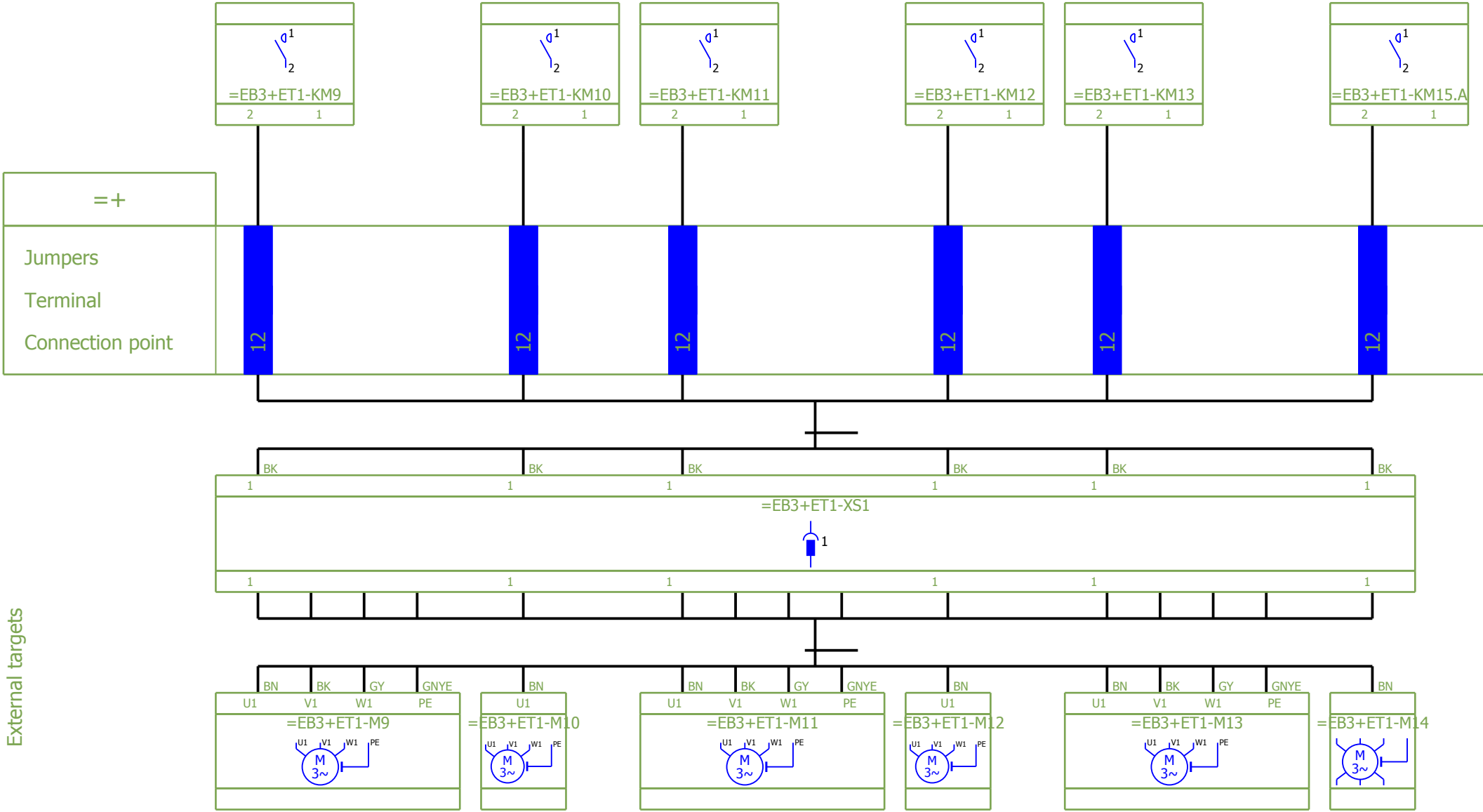

External targets

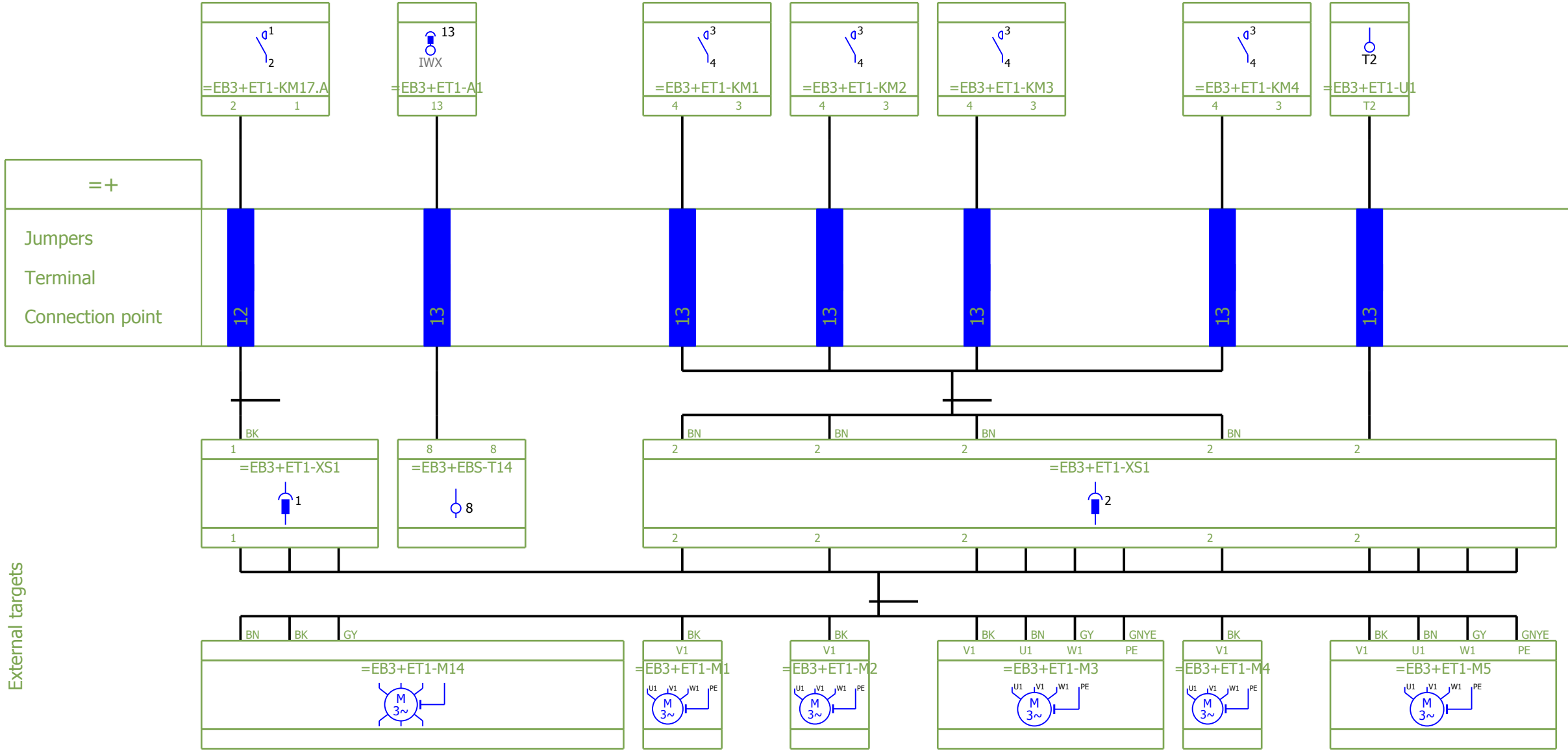

External targets

IT

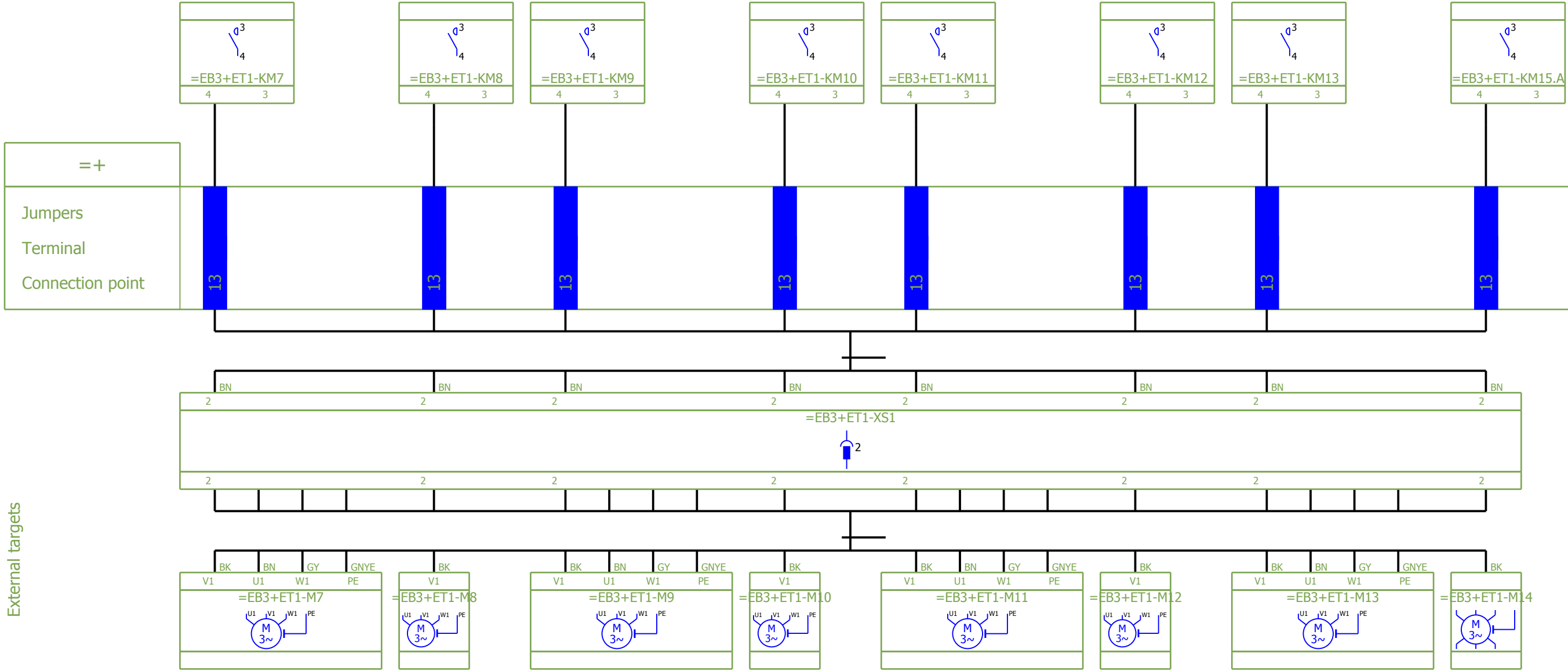

External targets

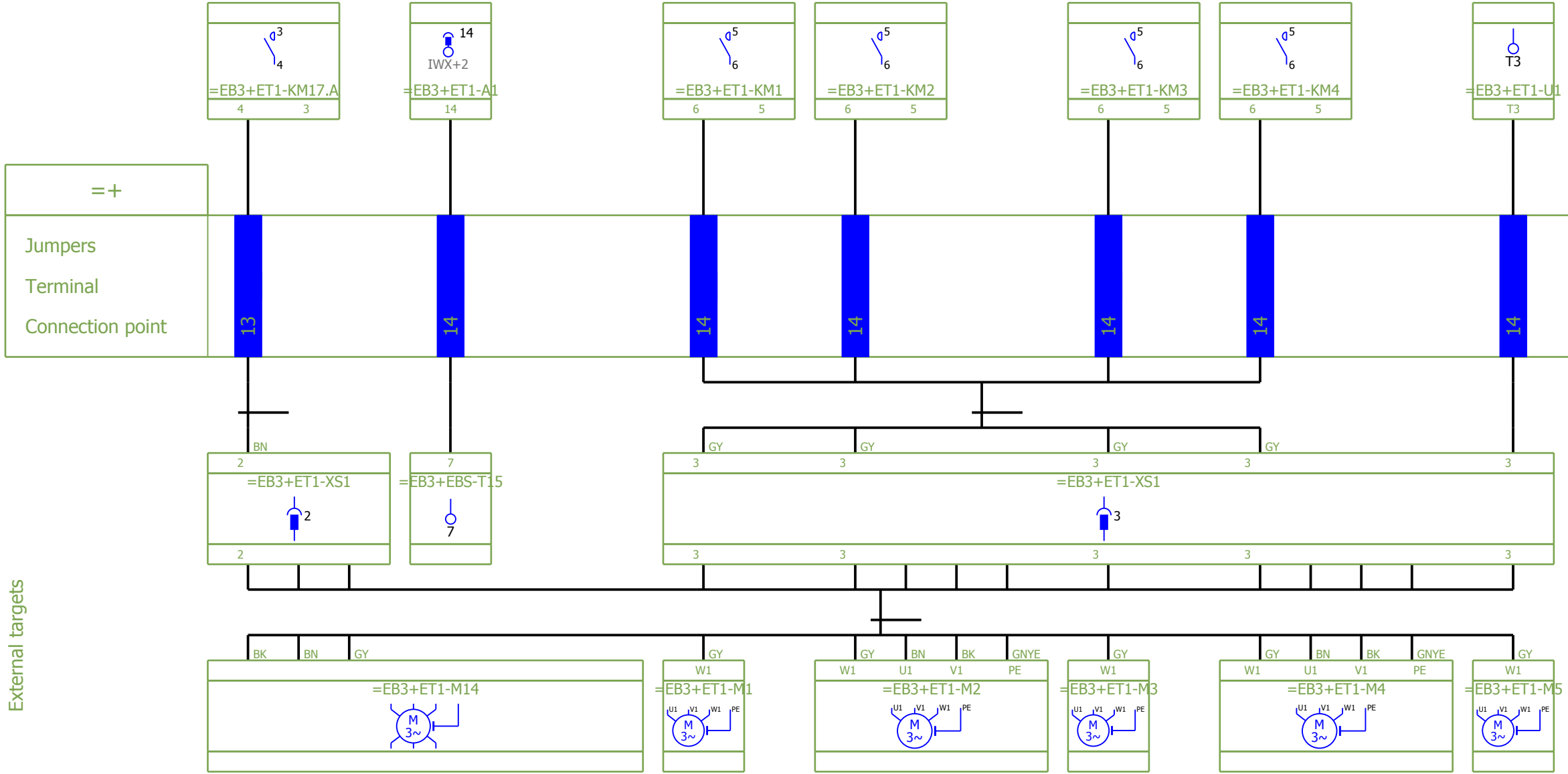

External targets

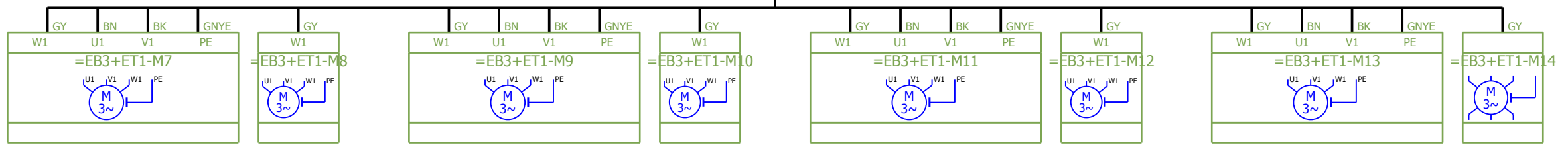
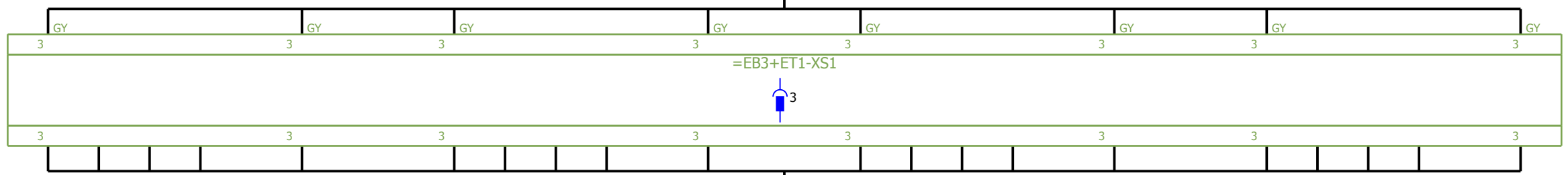
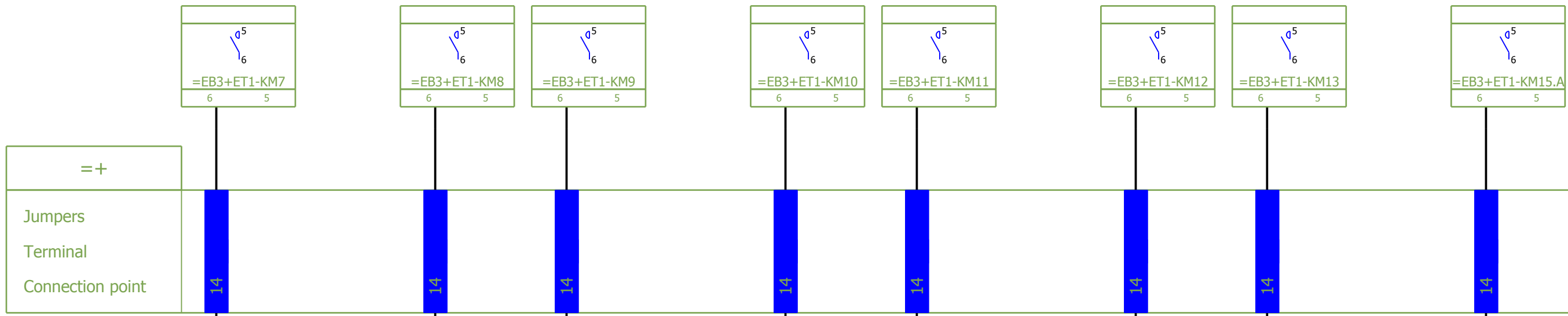

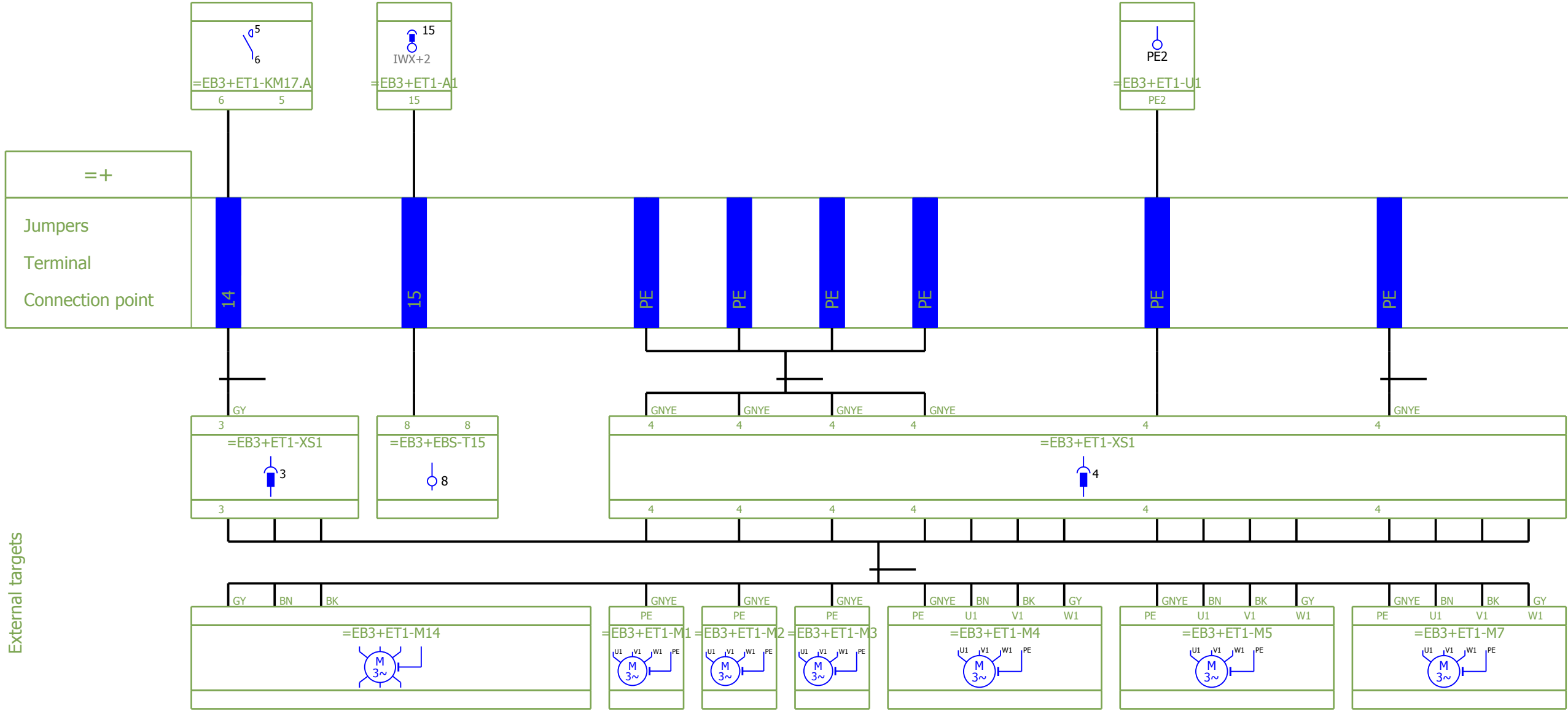

External targets

=+
Jumpers
Terminal
Connection point

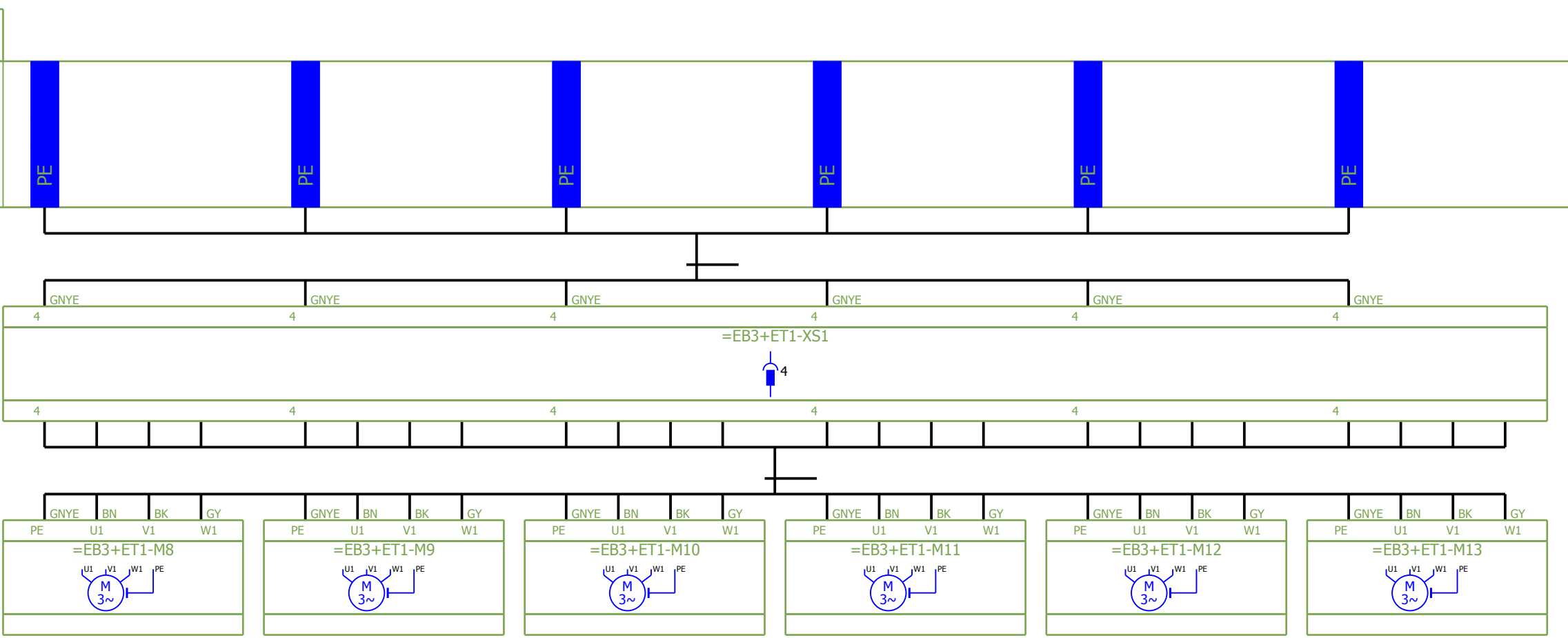

External targets



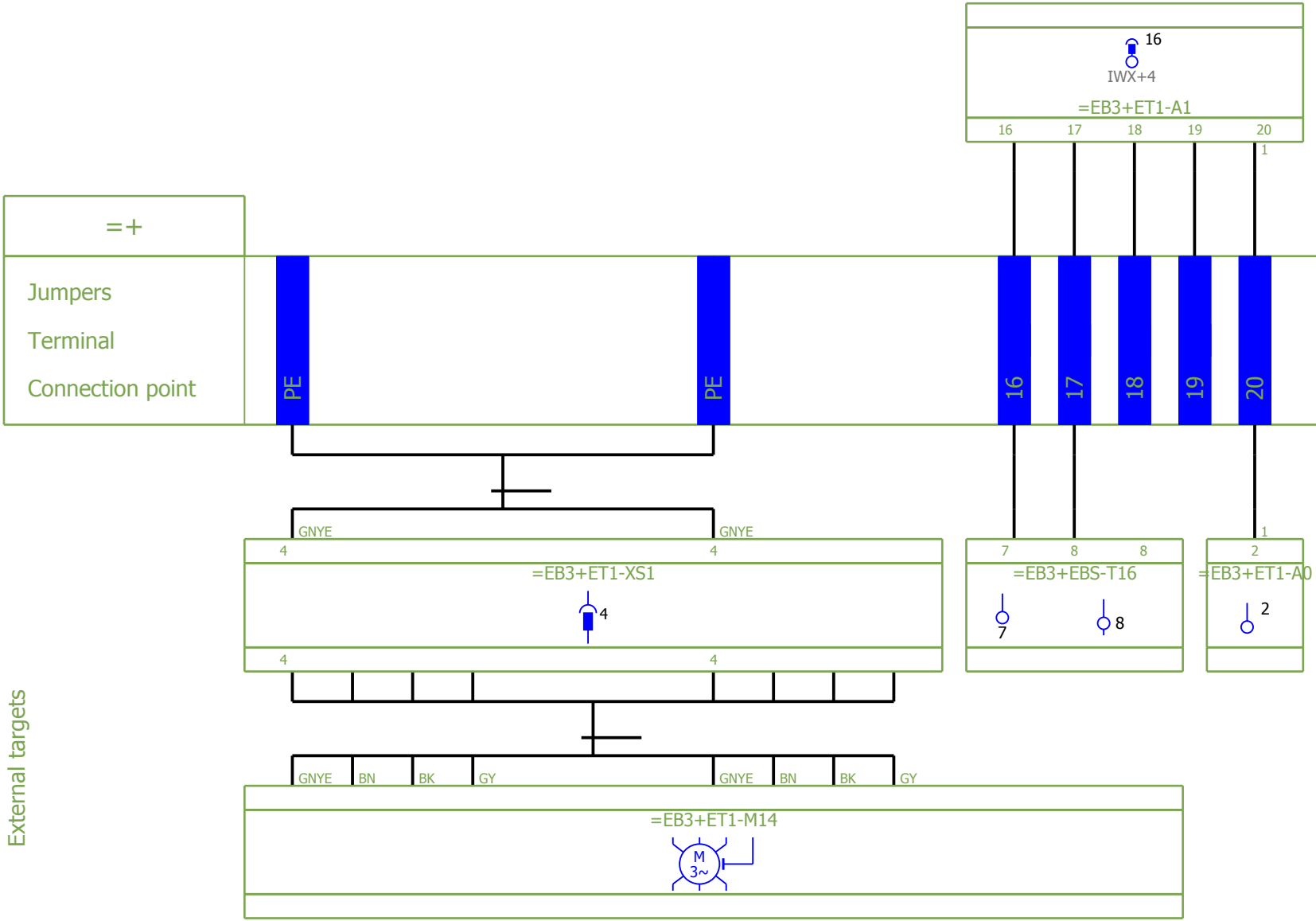

External targets

External targets

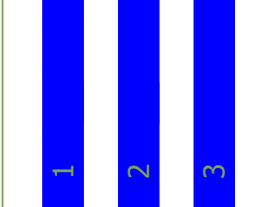

Internal targets

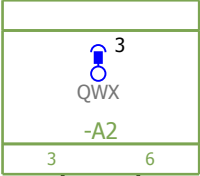
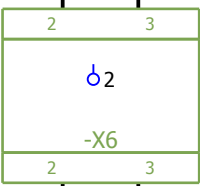

External targets

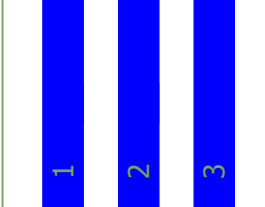

Internal targets

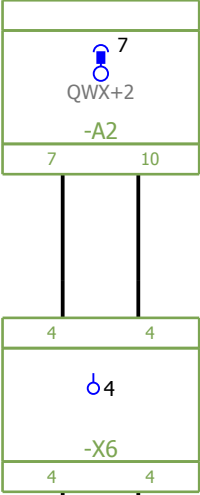

External targets



Internal targets

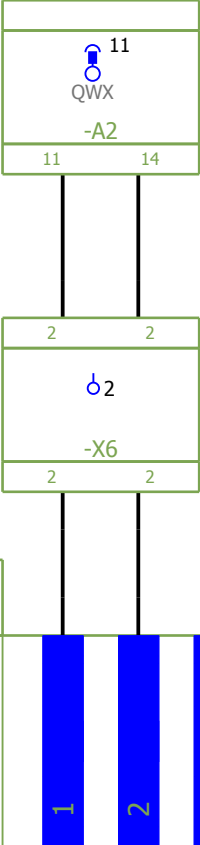

Internal targets

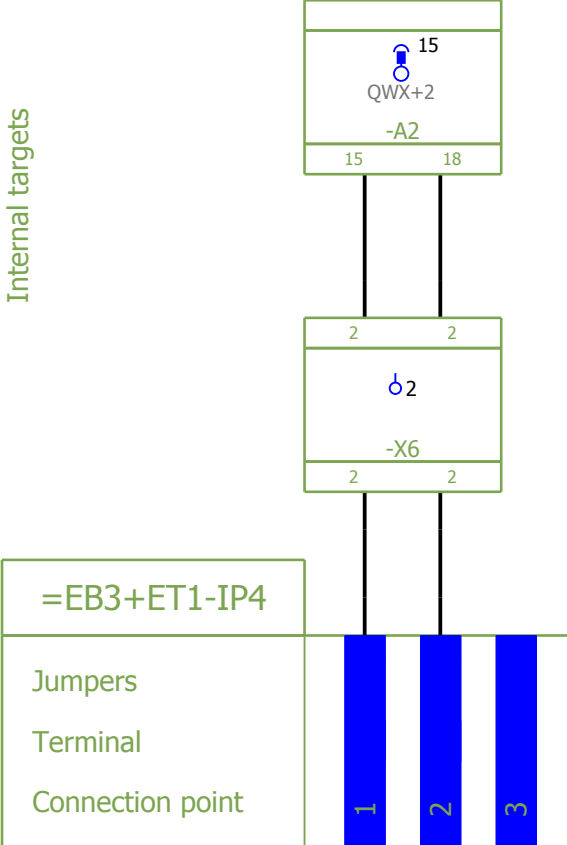

External targets

External targets



Internal targets

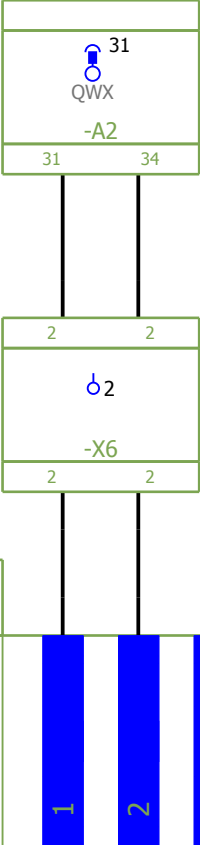

External targets

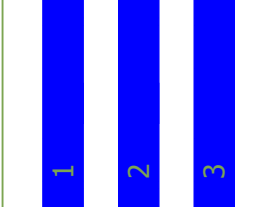

Internal targets

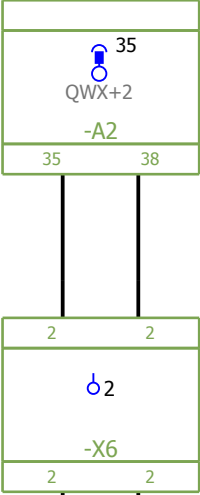

External targets

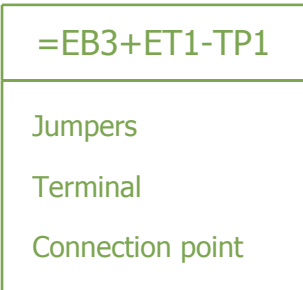

Internal targets

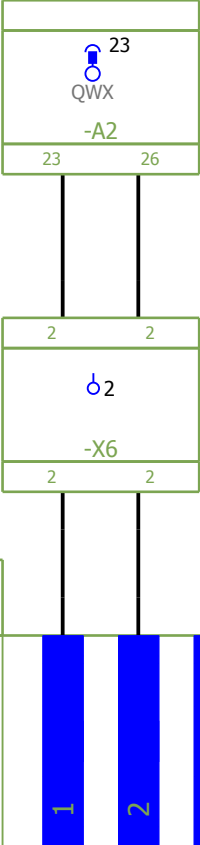



External targets

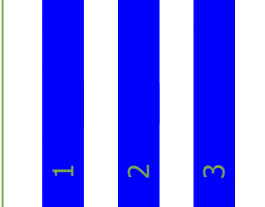
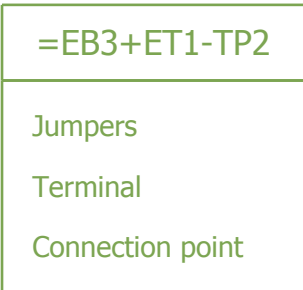

Internal targets

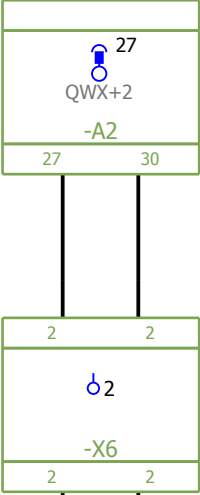

=EB3+ET1-W2

Jumpers

Terminal

Connection point

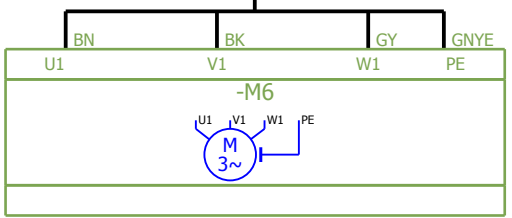
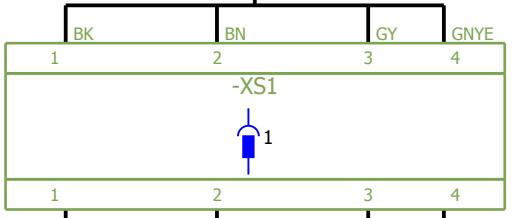
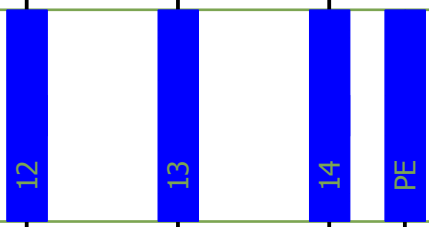
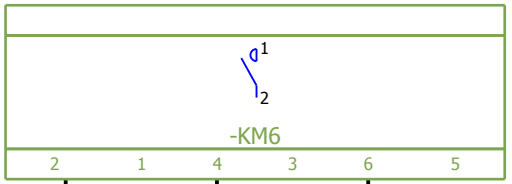

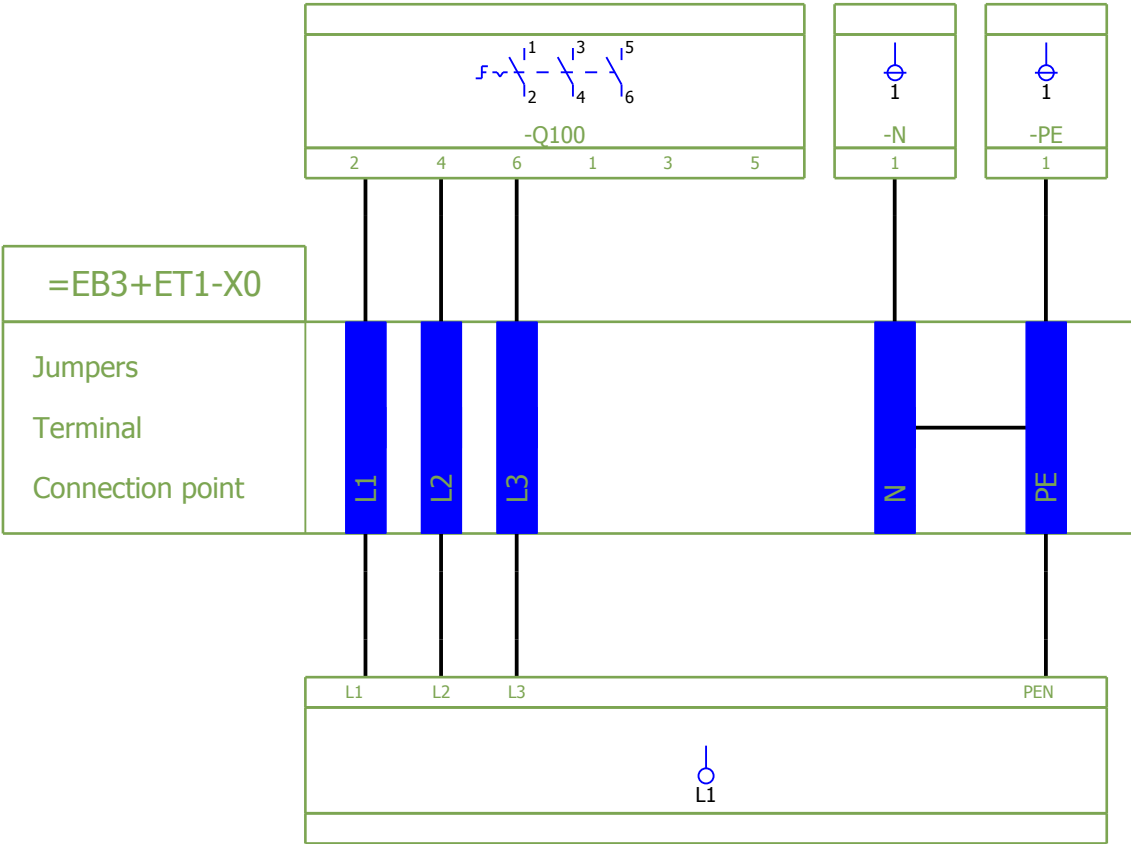

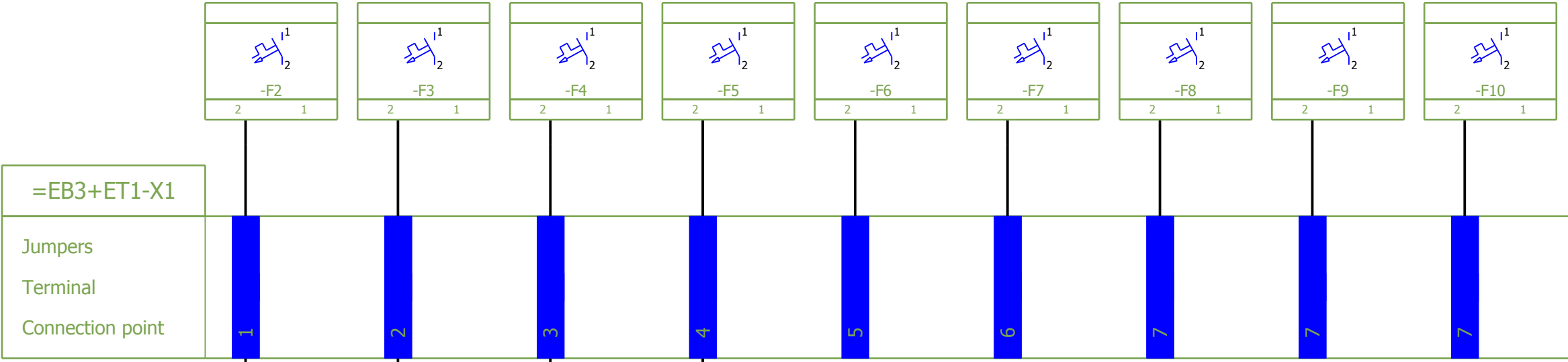

IT

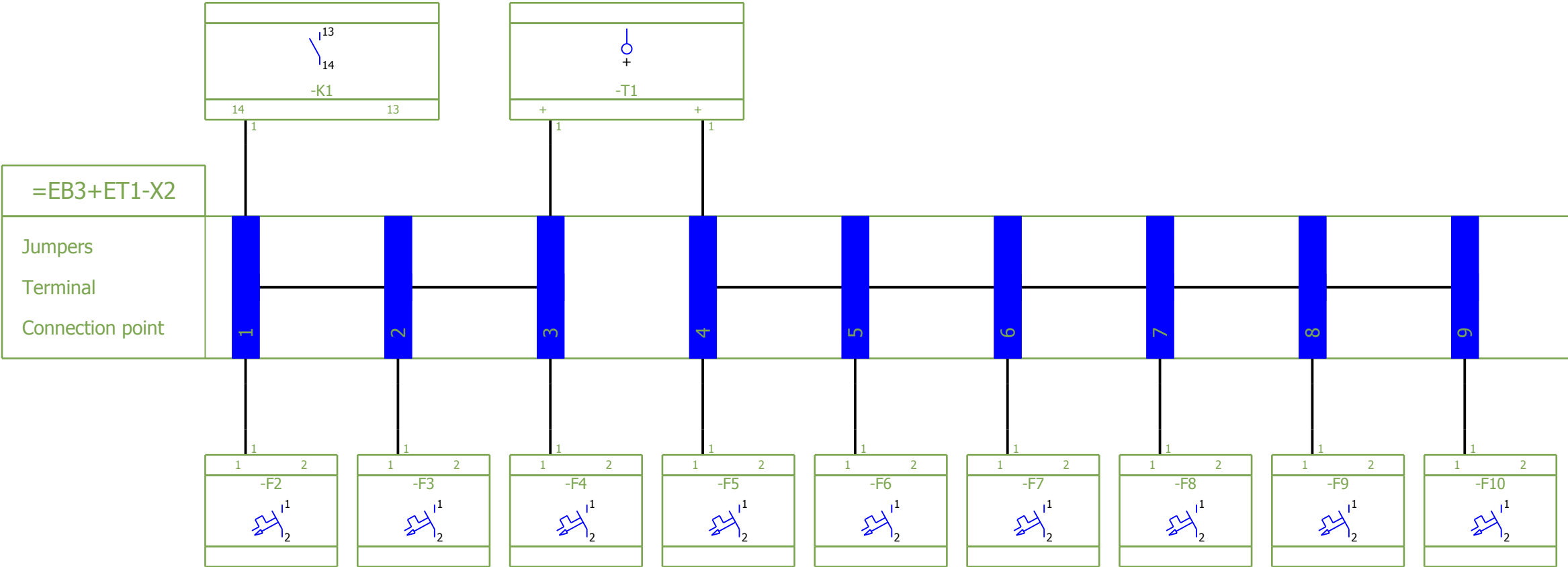

External targets

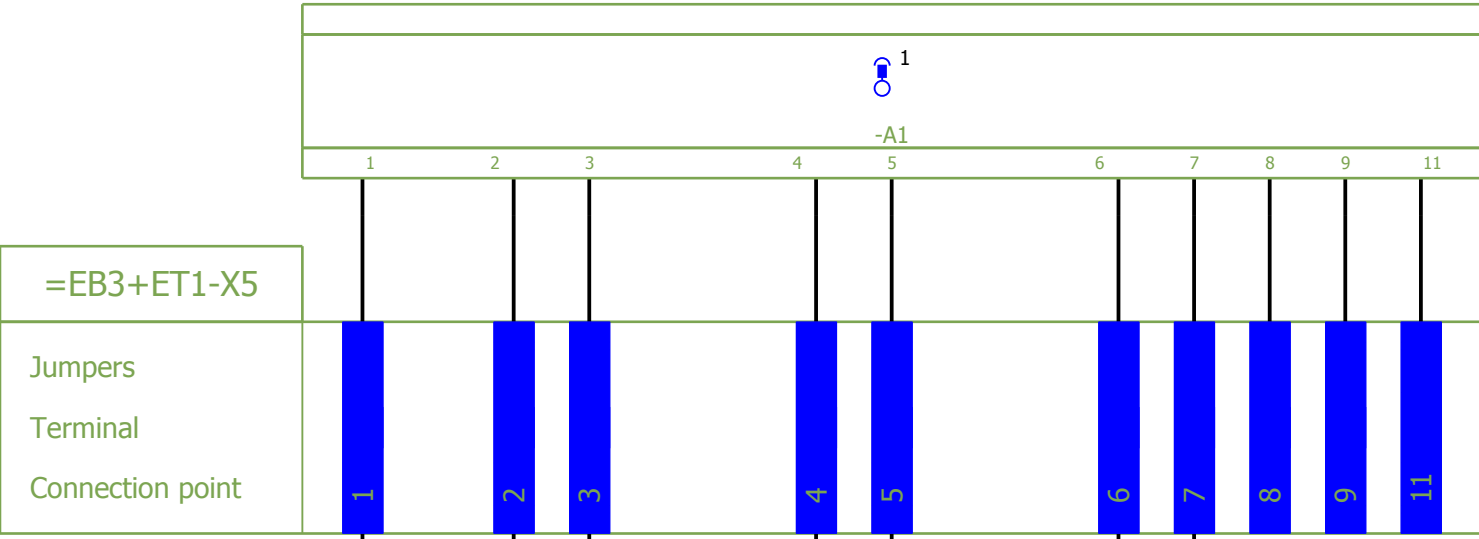

External targets

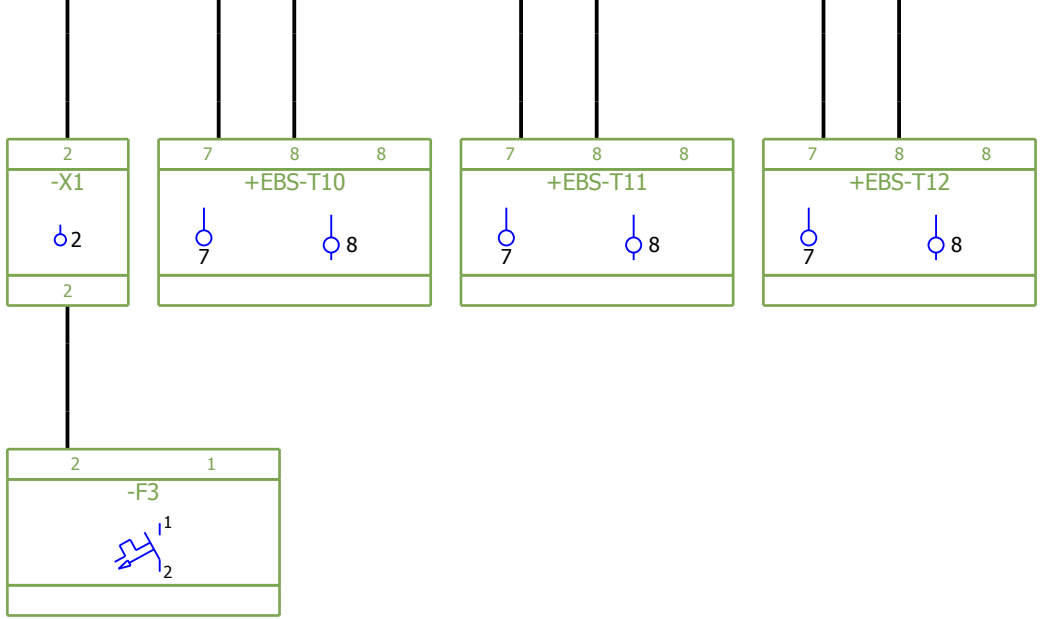

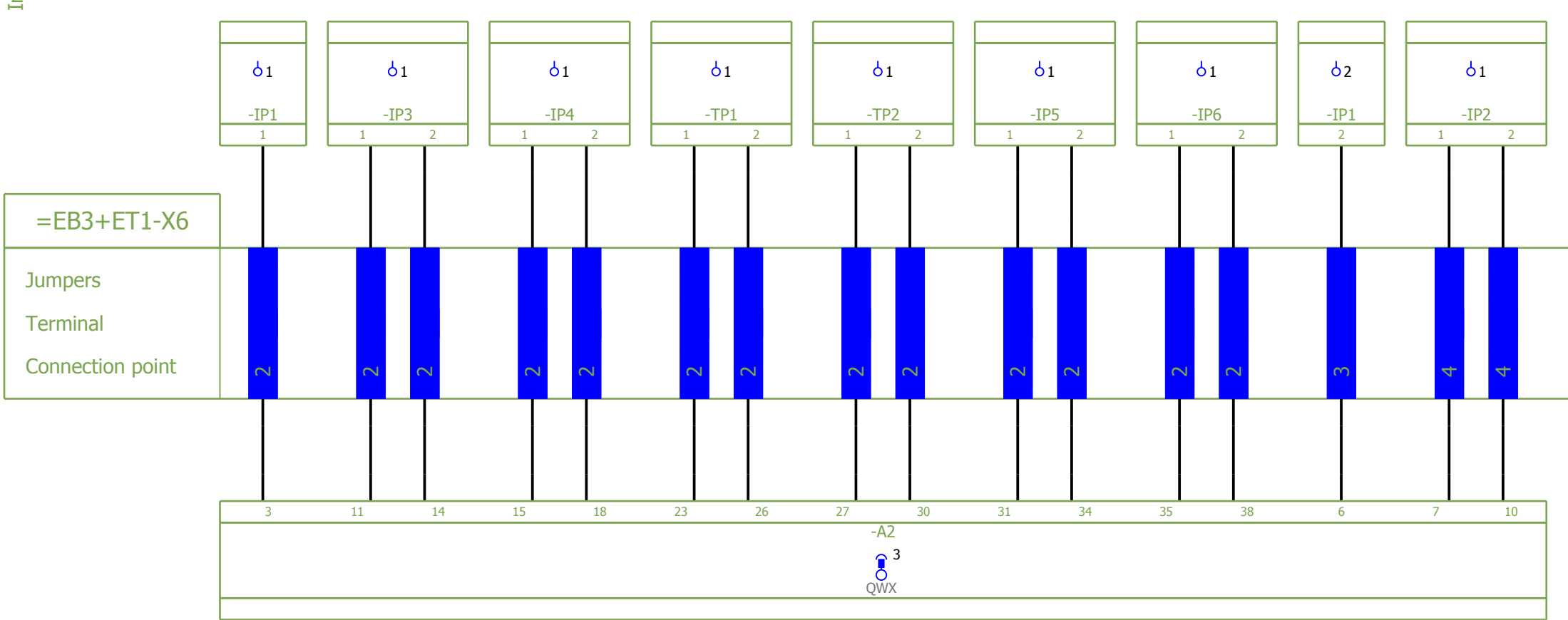

External targets

IT

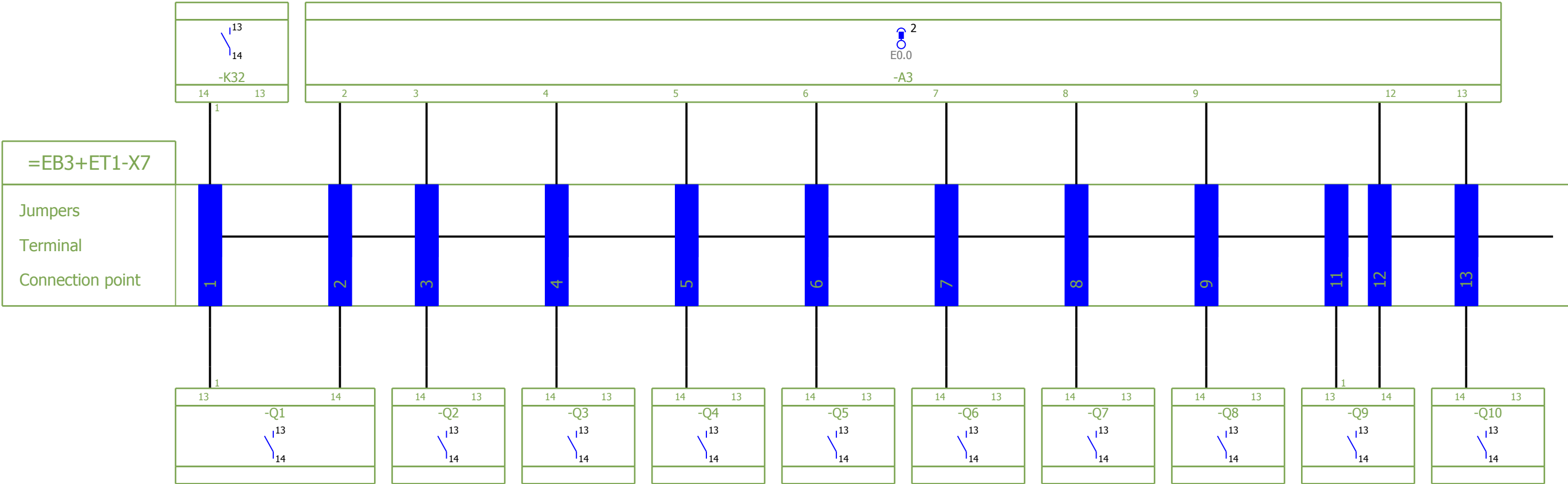

External targets

=EB3+ET1-X7  
Jumpers  
Terminal  
Connection point



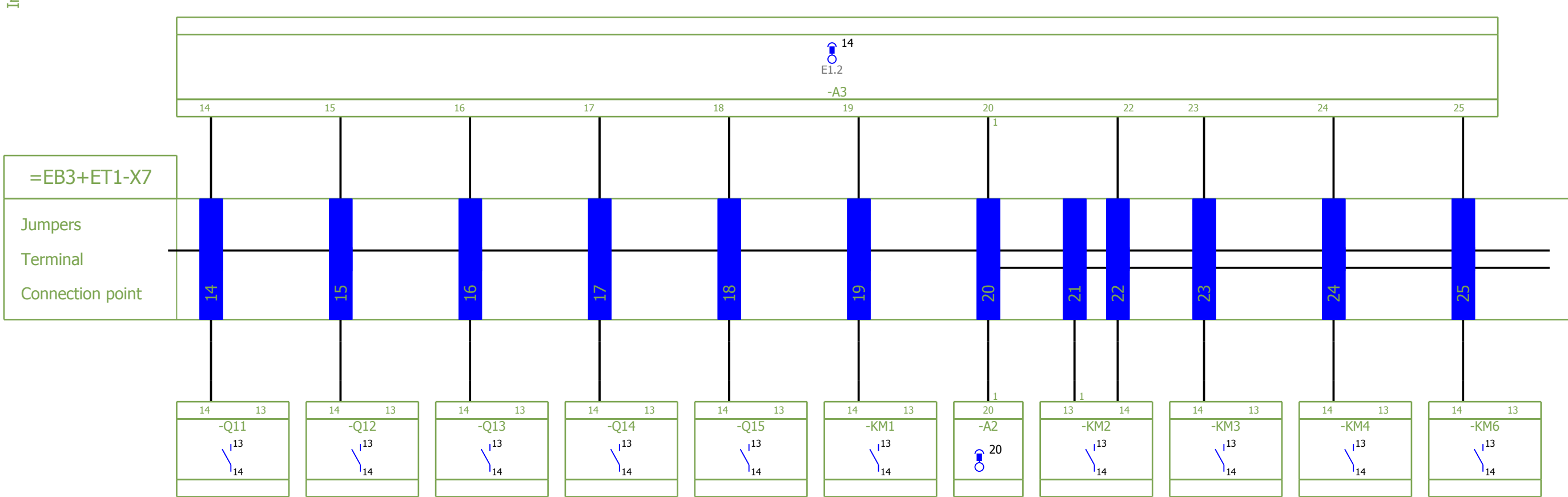

External targets

IT

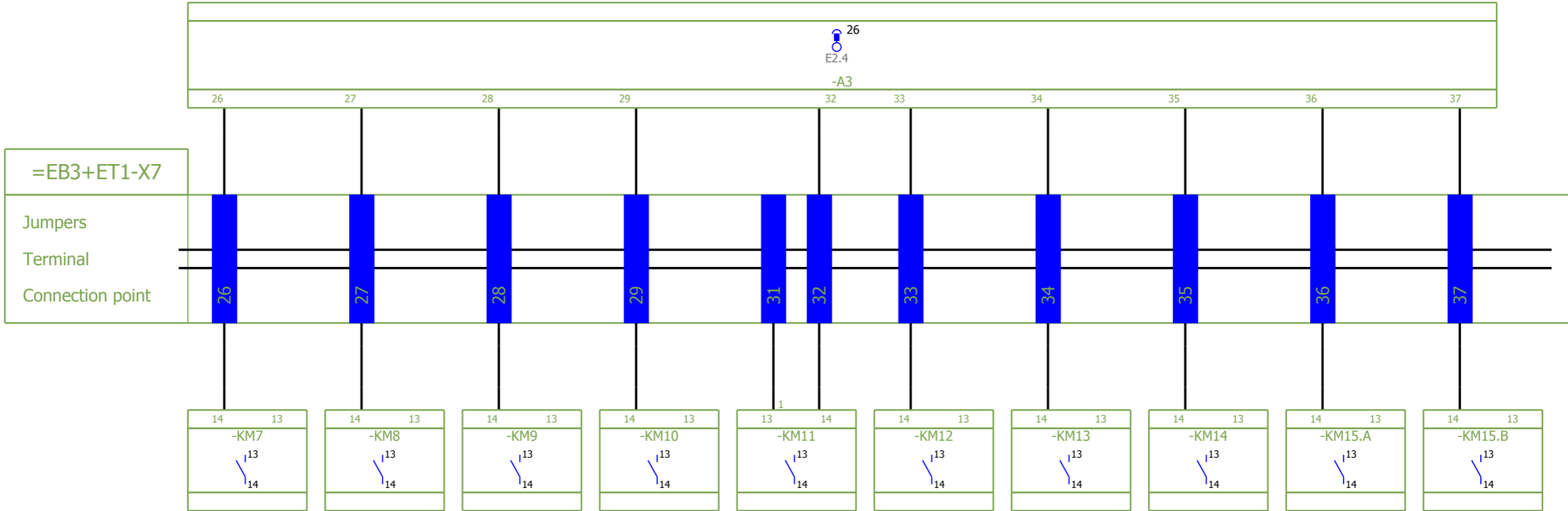

External targets

IT

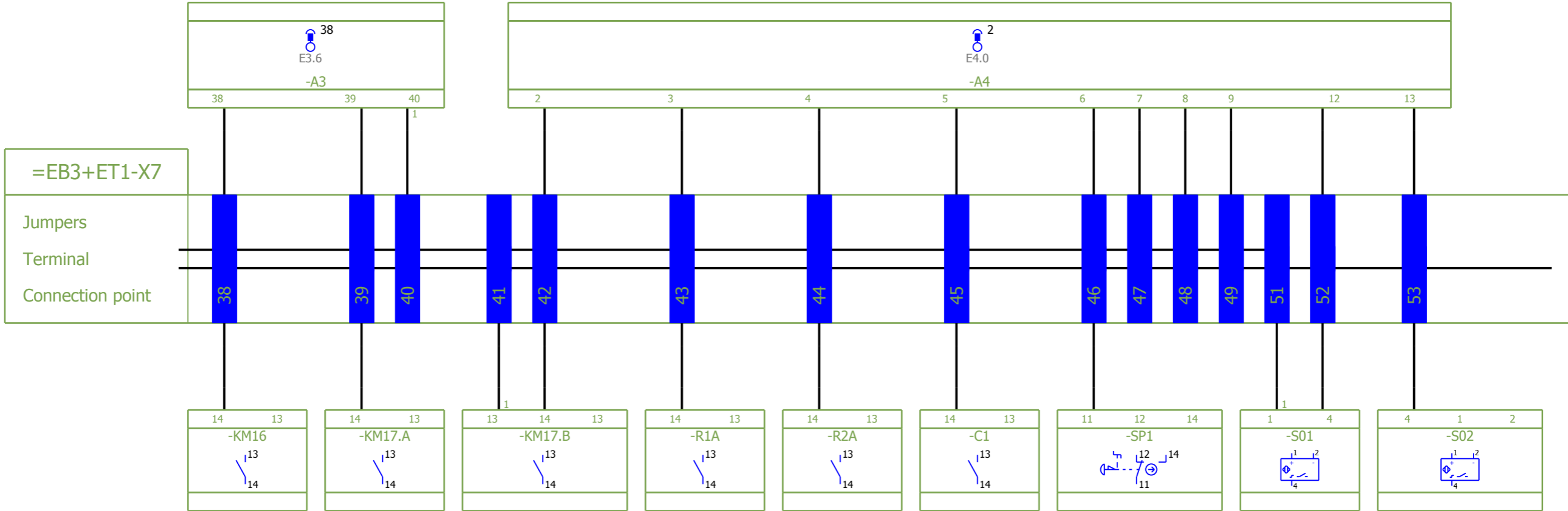

External targets

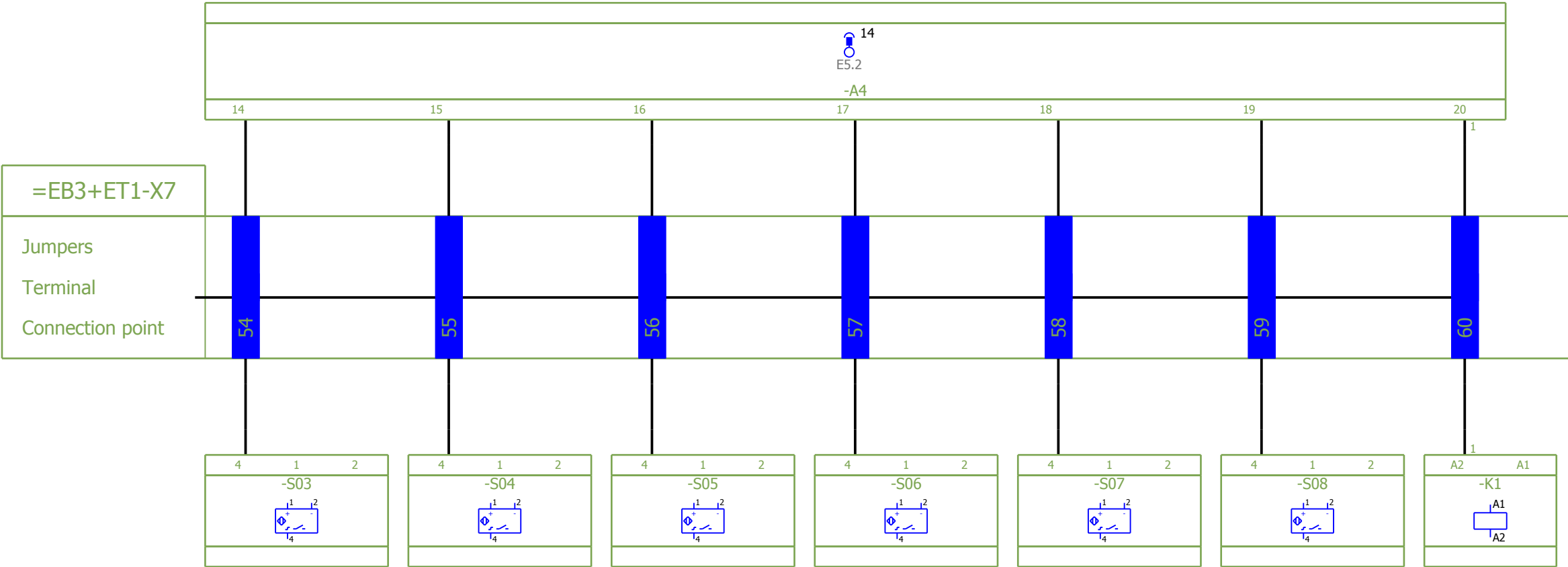

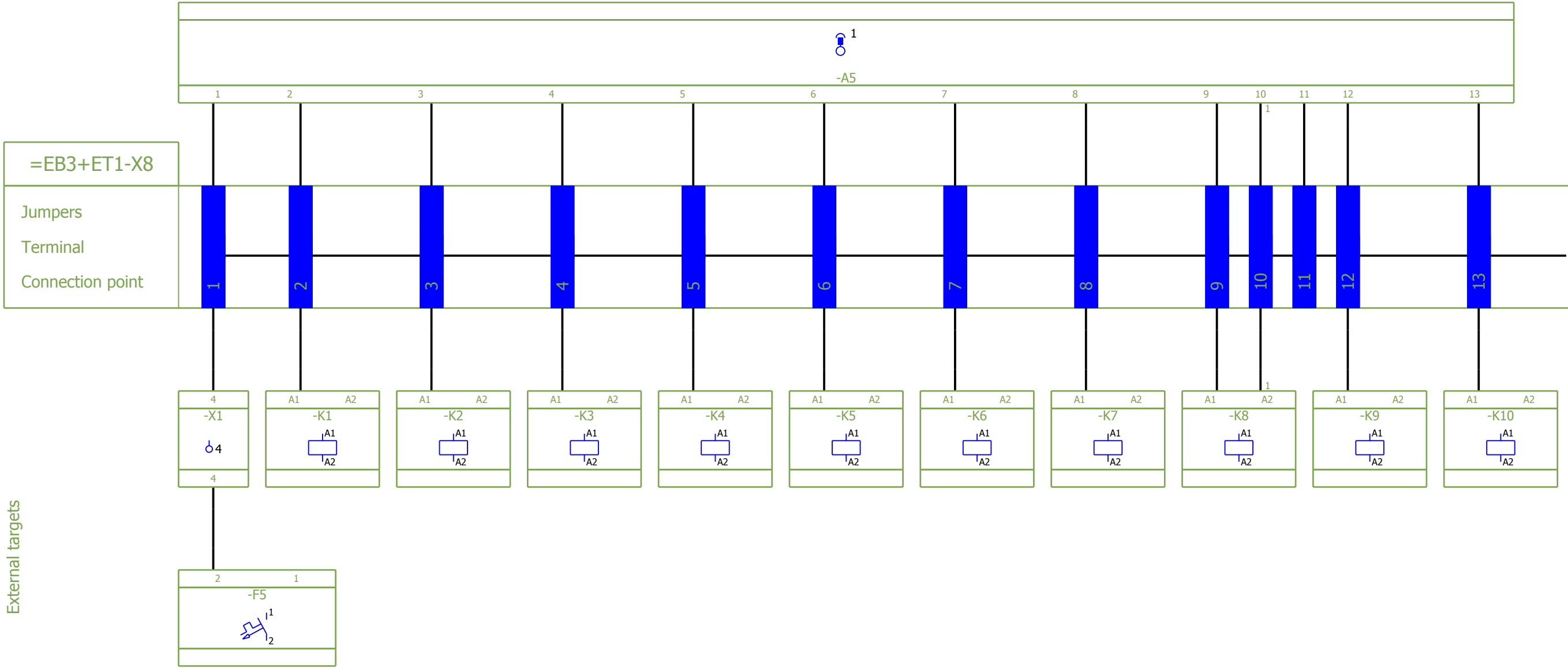

External targets

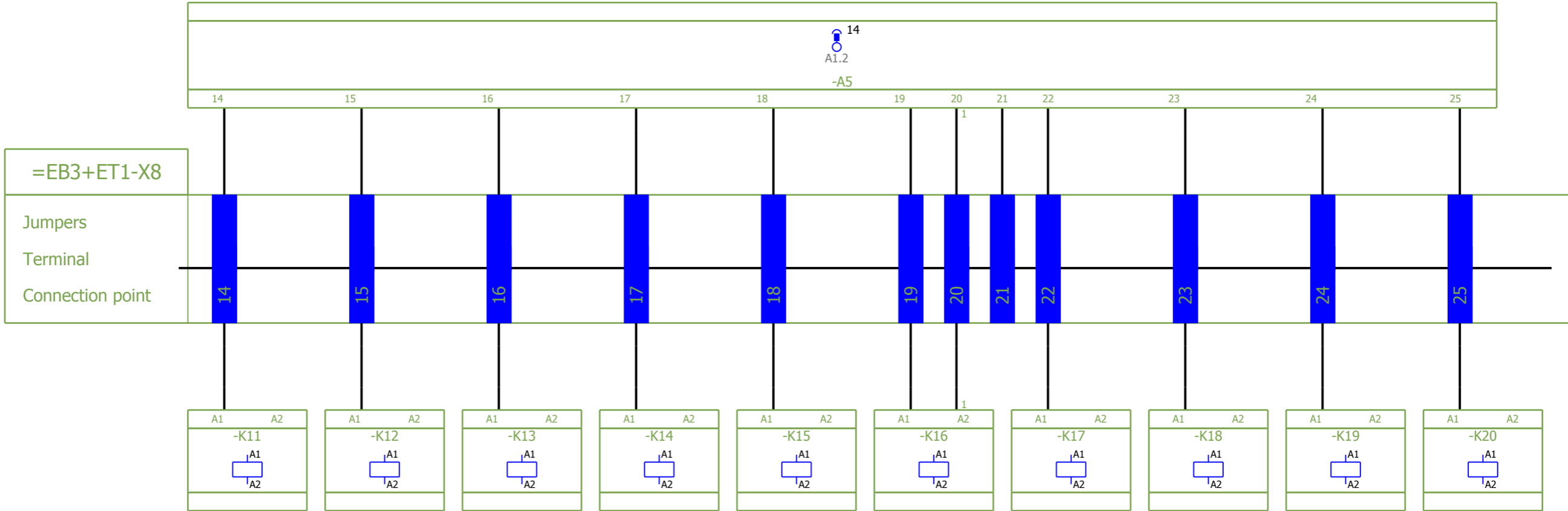

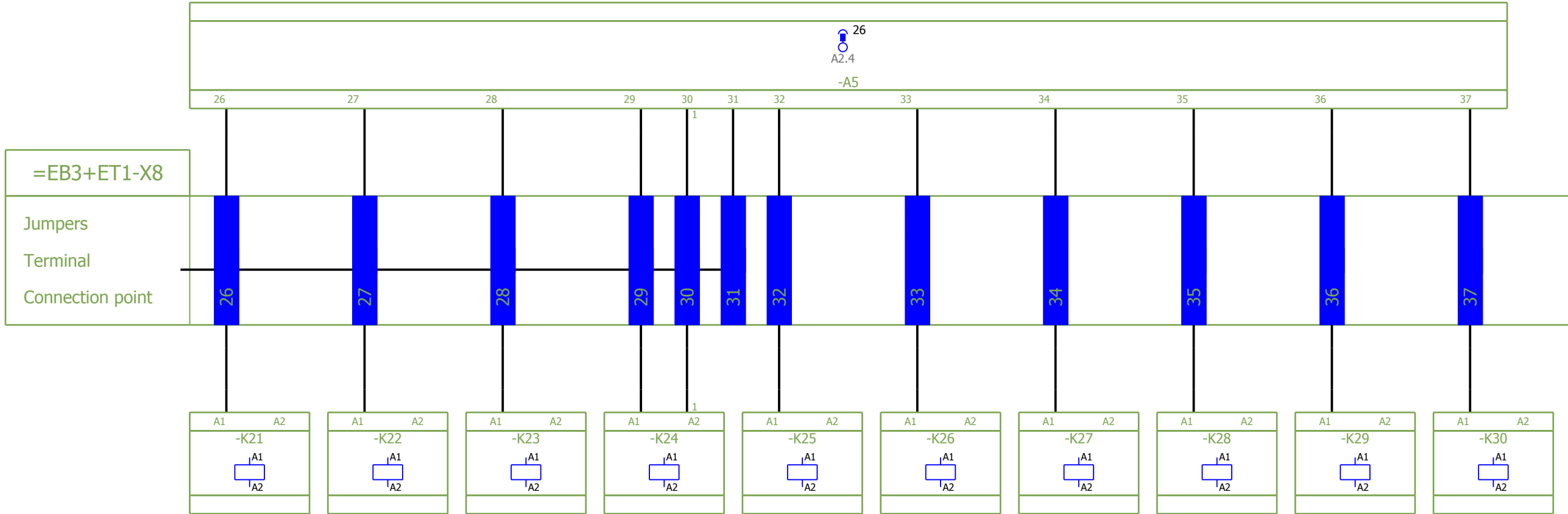

External targets

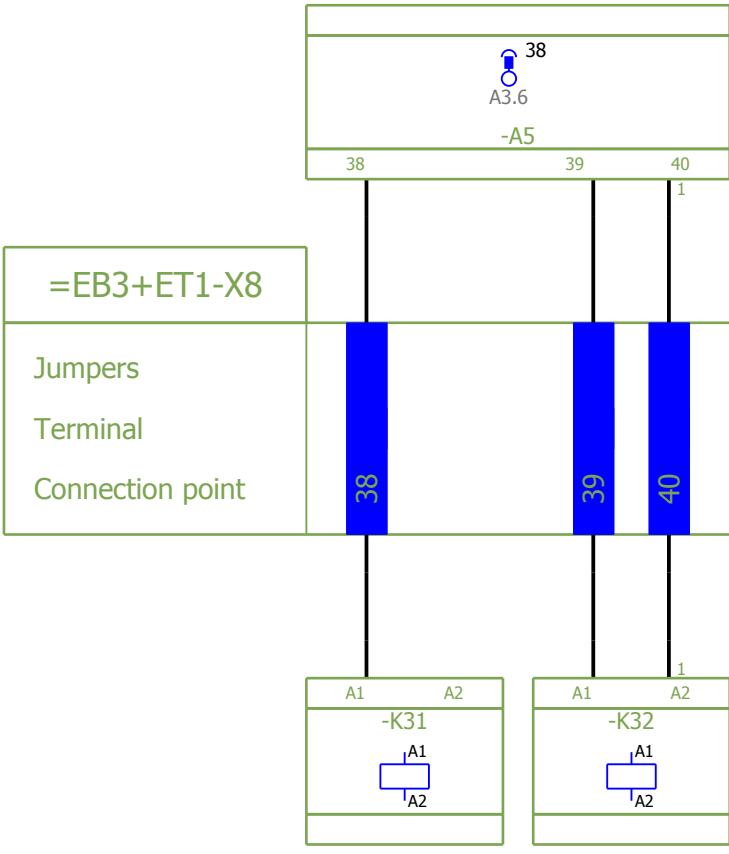



Internal targets

=EB3+ET2-X1

Jumpers

Terminal

Connection point

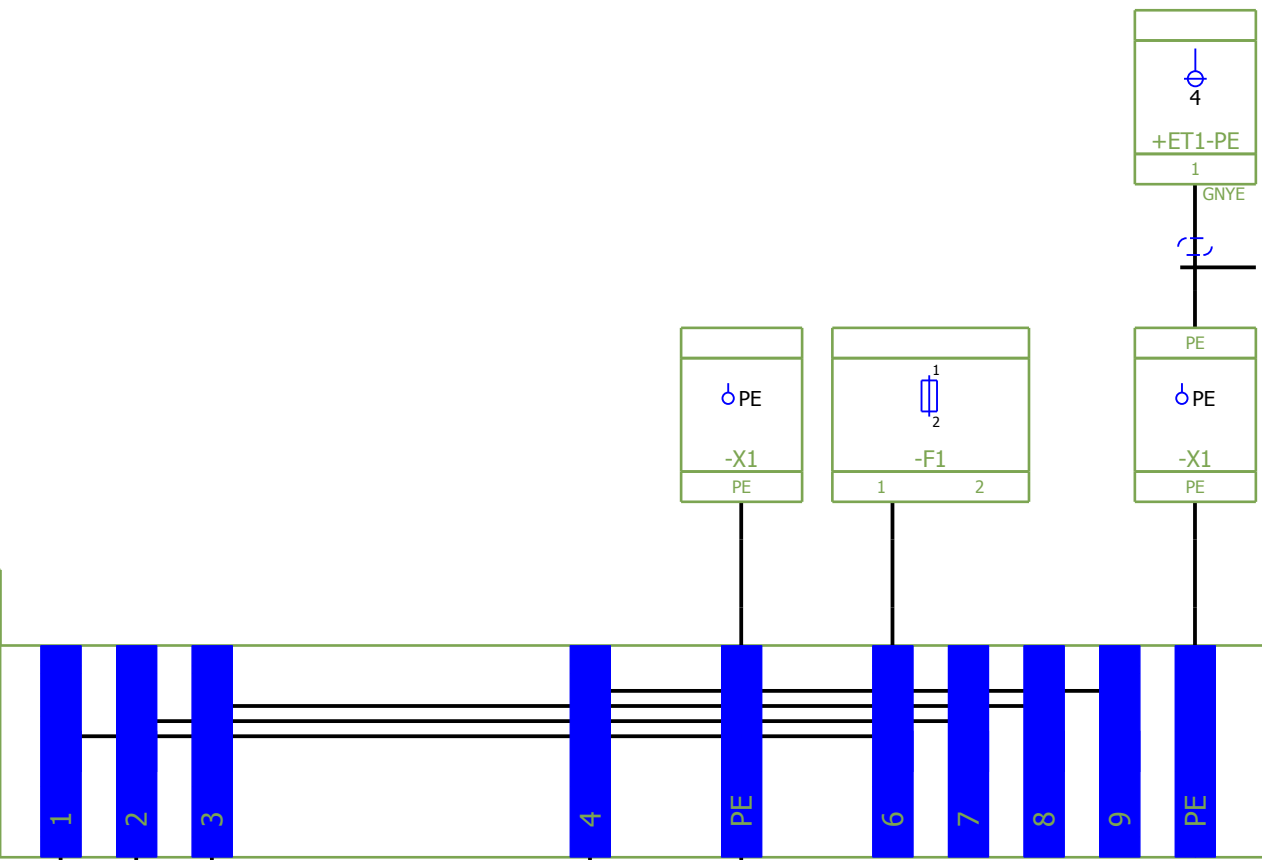

External targets

BK BN GY 1 3 5

+ET1-F200

1 2 3 4 5 6

BU 1

+ET1-N

4

GNYE 1

+ET1-PE

4

External targets

=EB3+ET2-X5
Jumpers
Terminal
Connection point

-K50
14                      13

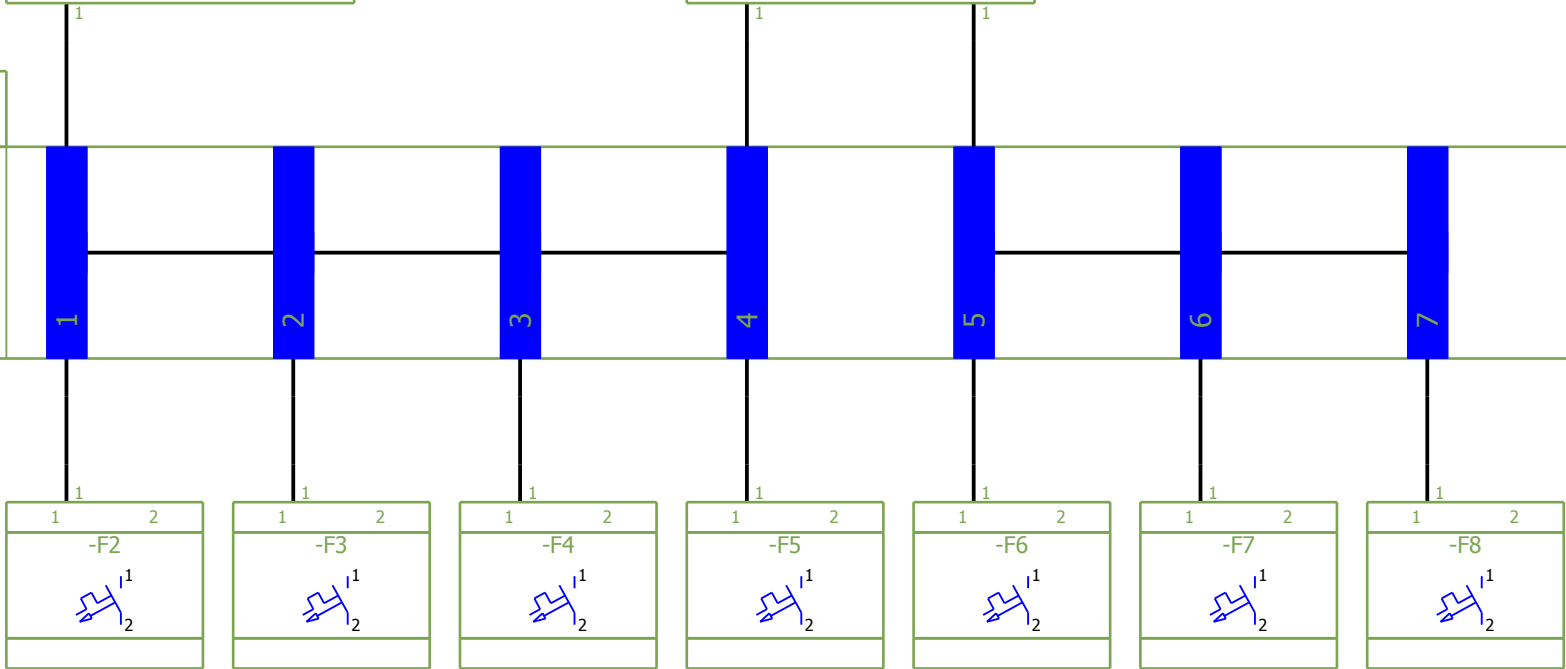

-T1
+                      +

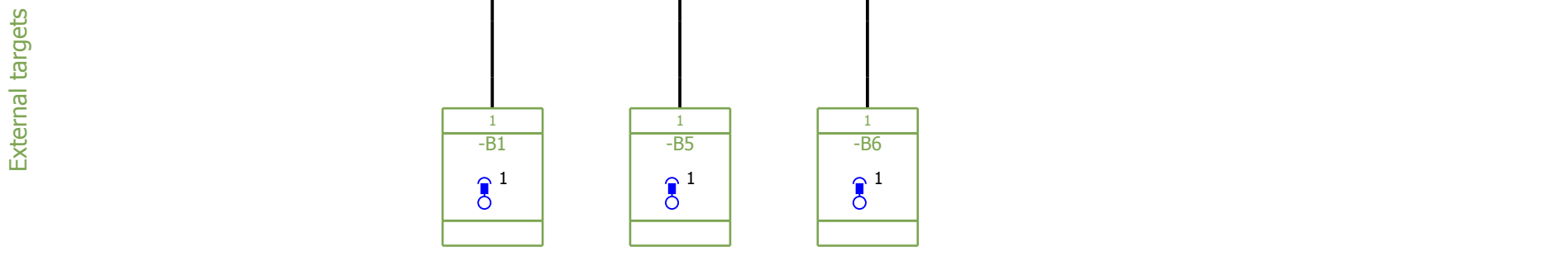
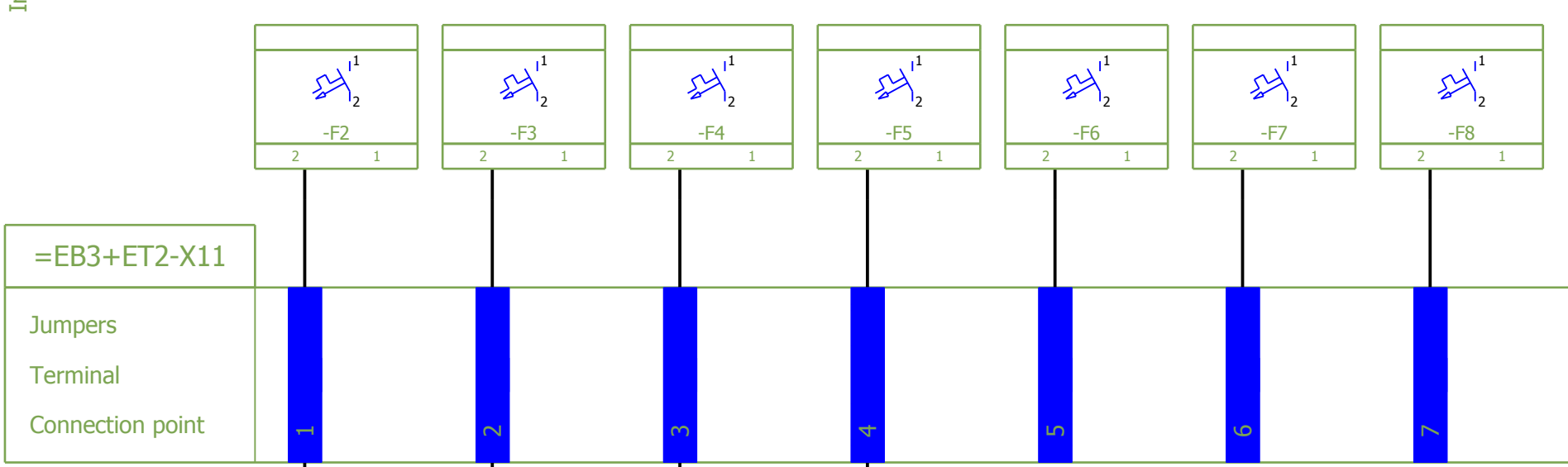

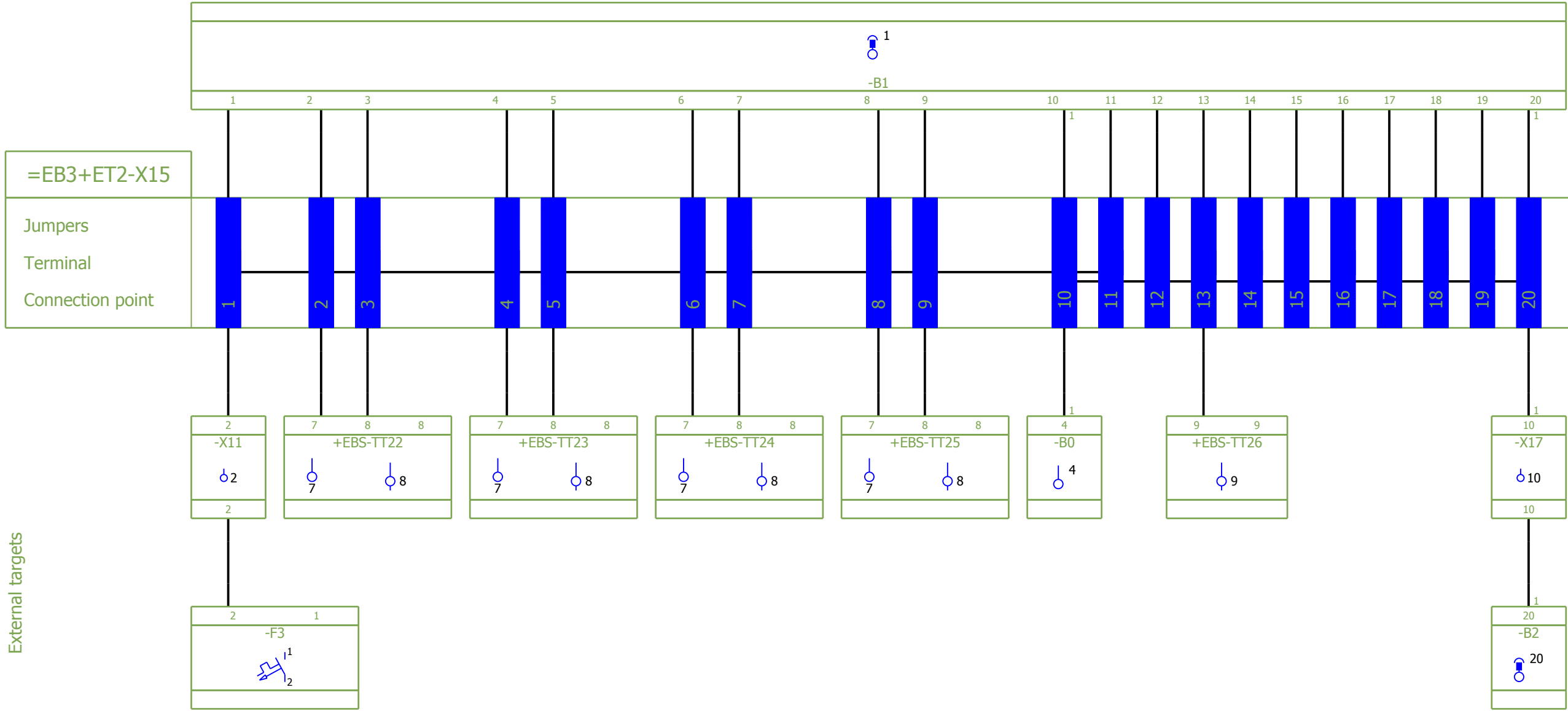

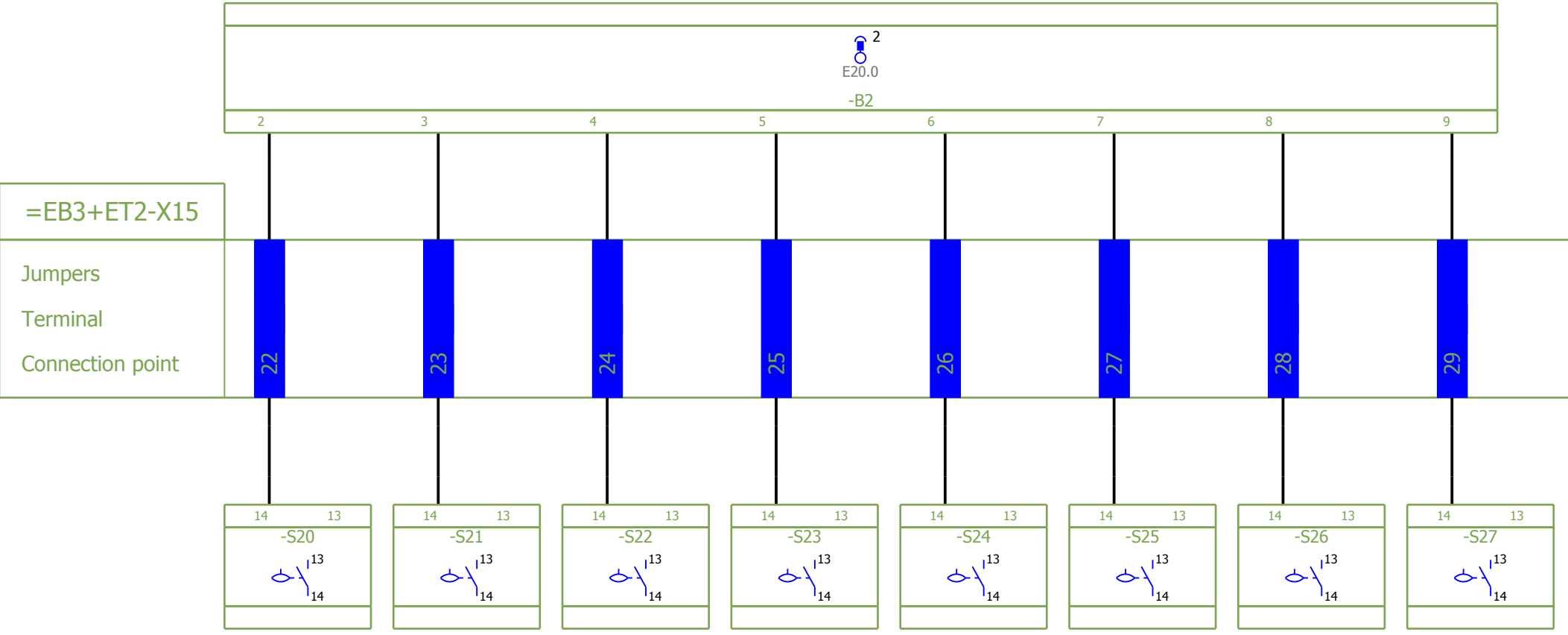

External targets



IT

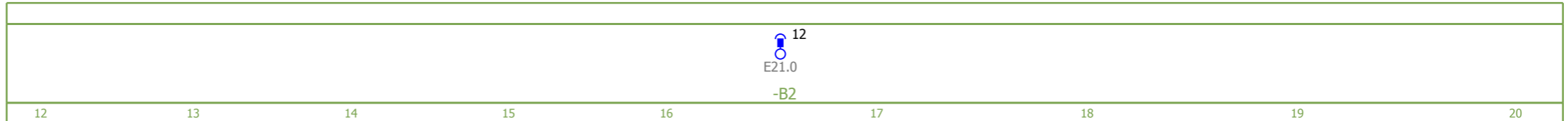

=EB3+ET2-X17

Jumpers

Terminal

Connection point

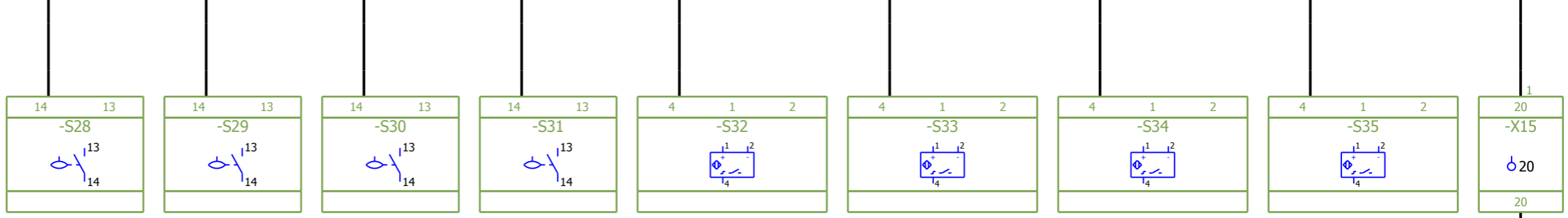
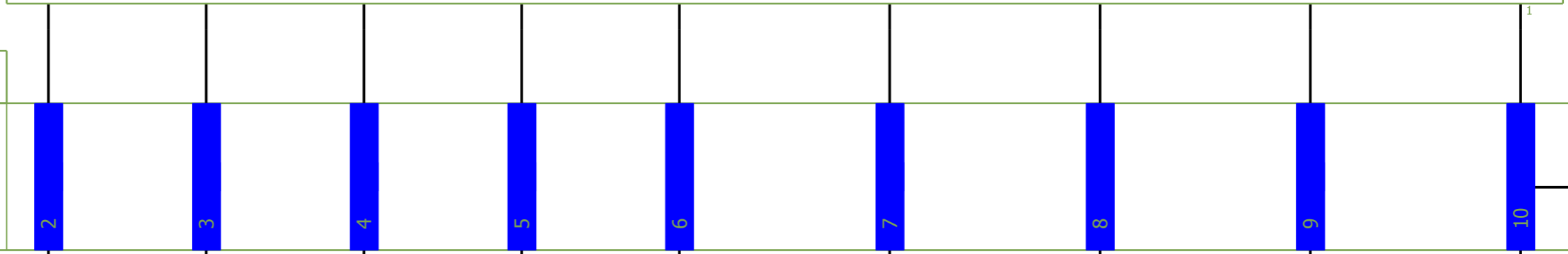

External targets

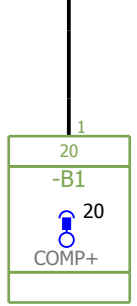

IT

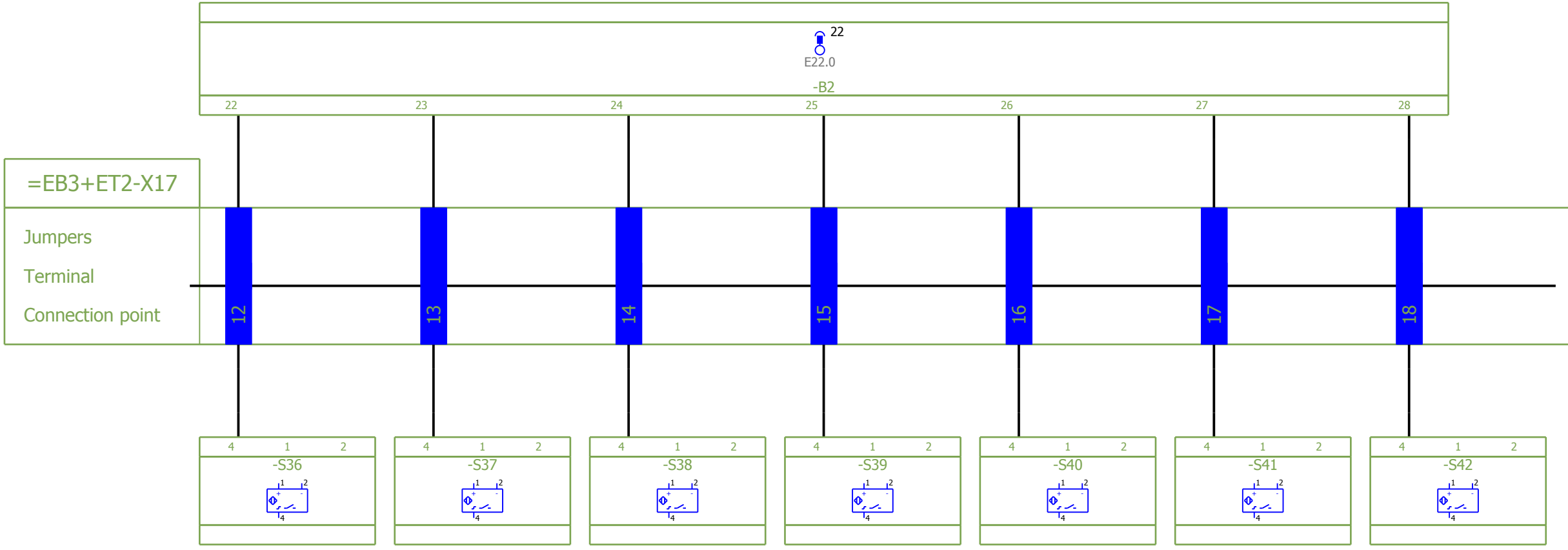

External targets

External targets

=EB3+ET2-X17  
Jumpers  
Terminal  
Connection point

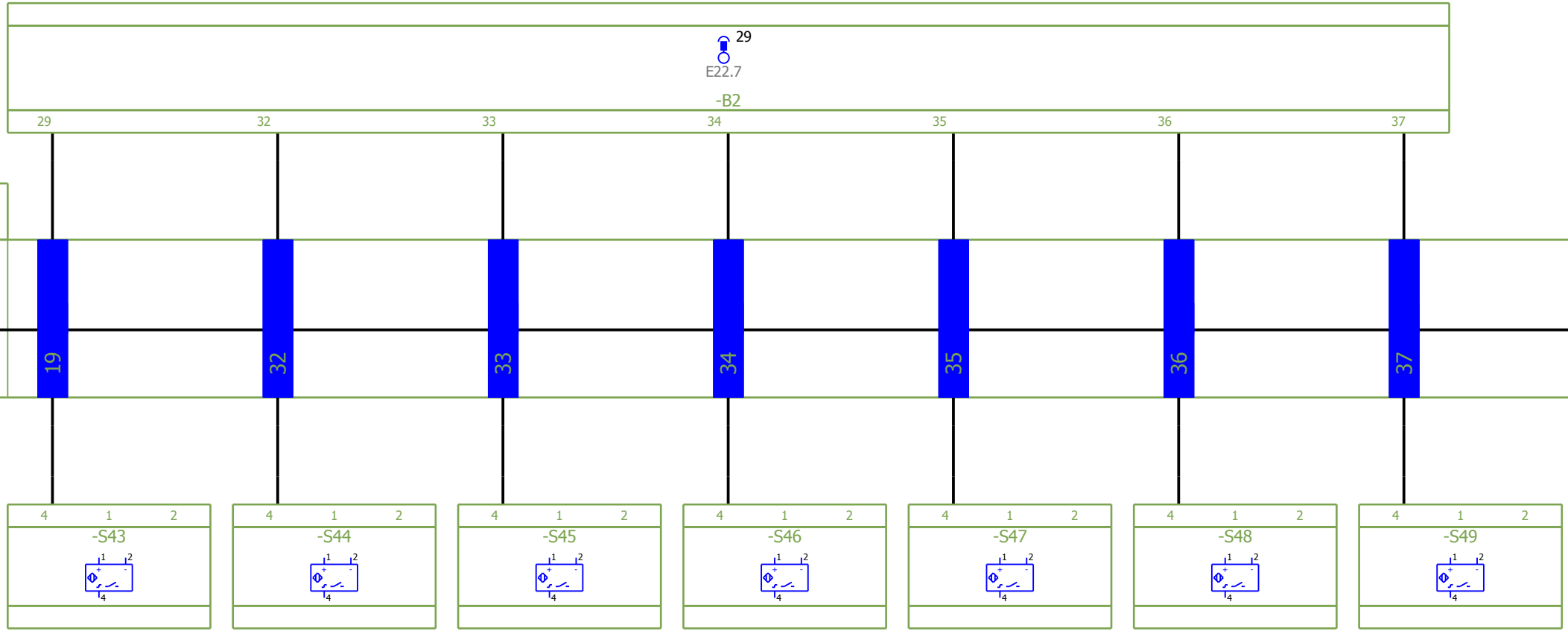



IT

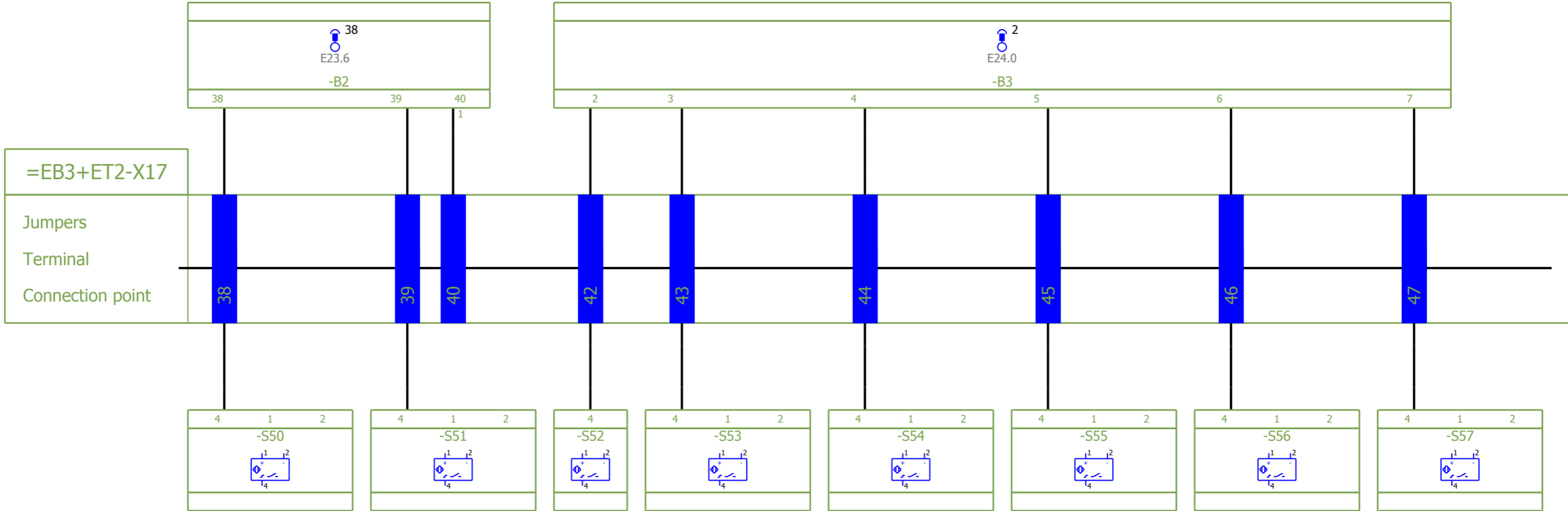

External targets

IT

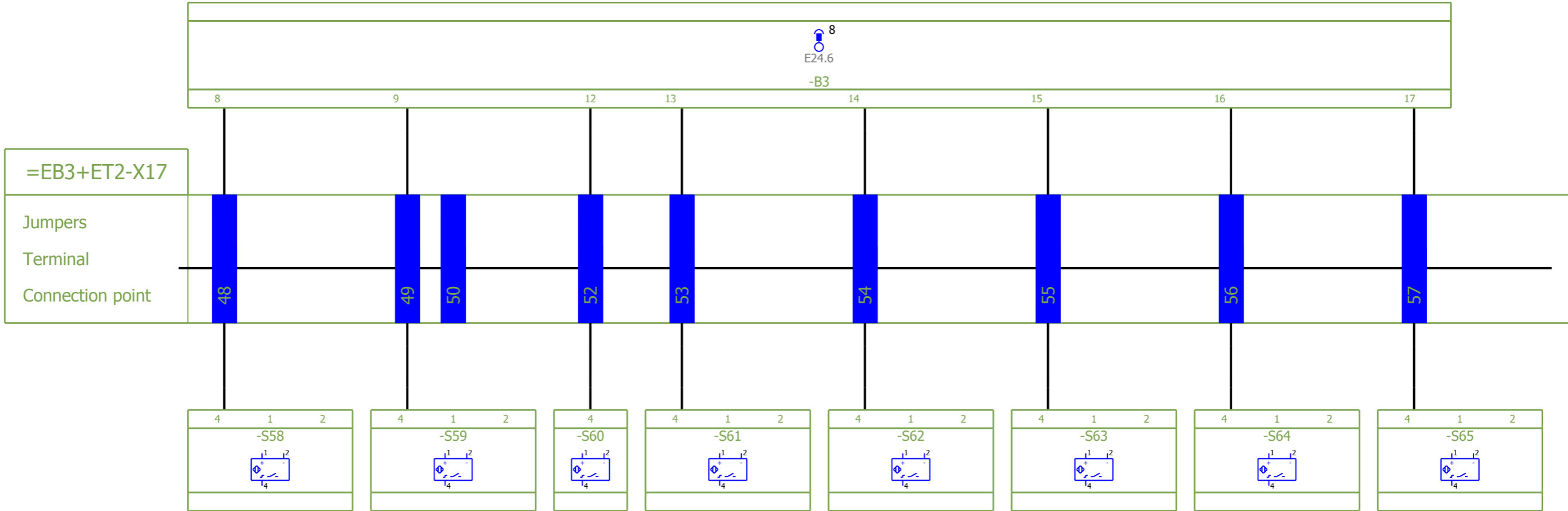

External targets

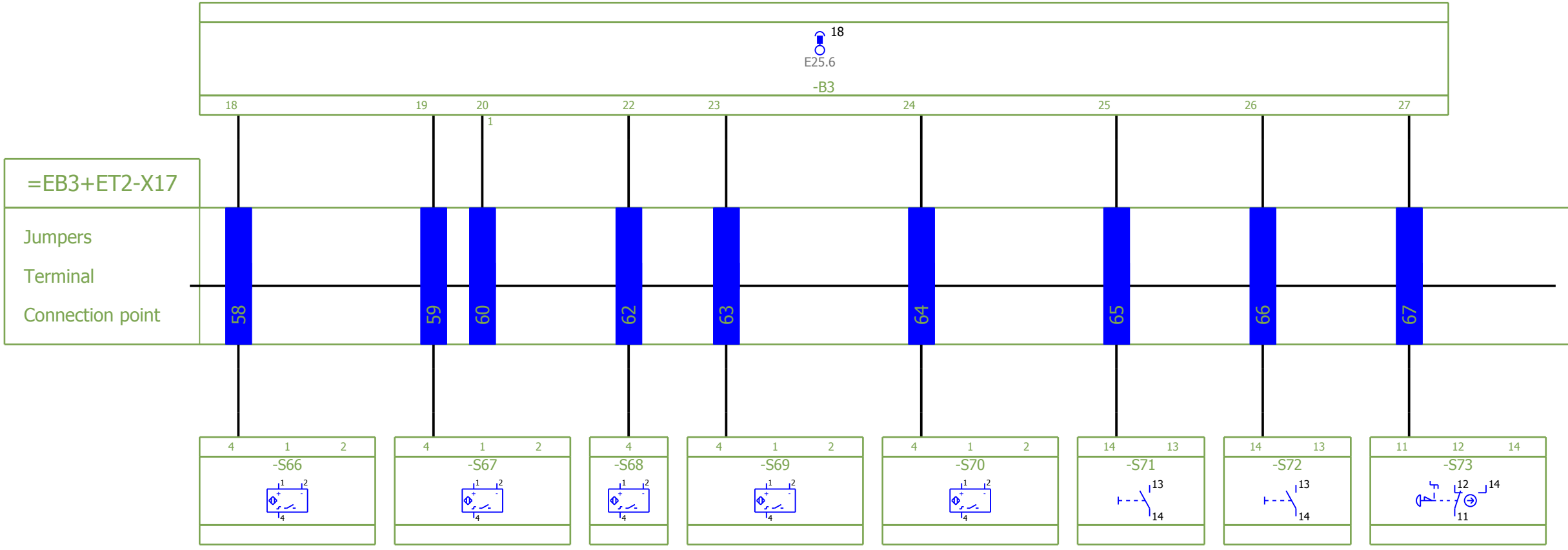

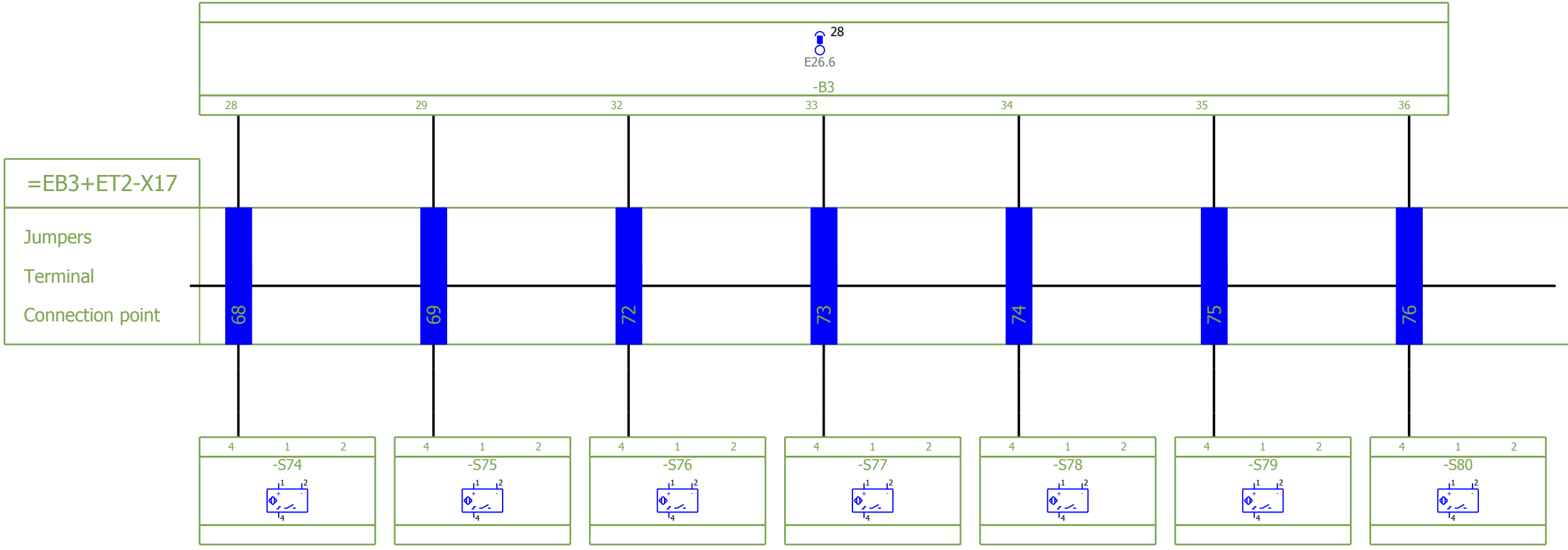

IT

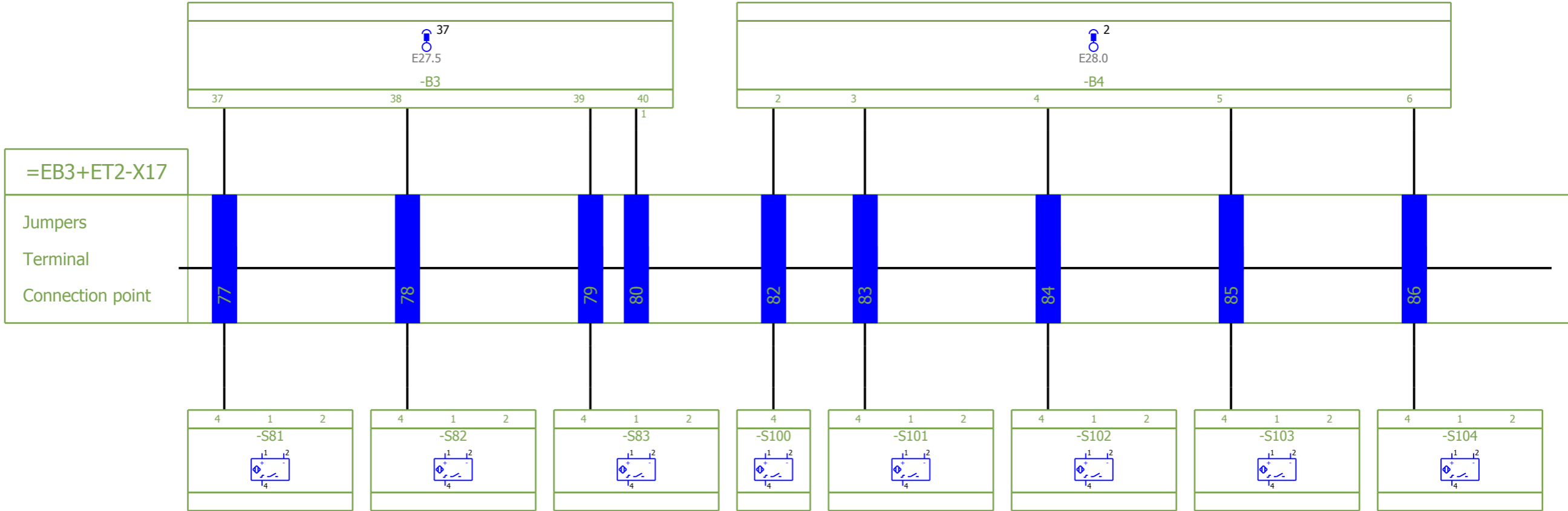

External targets

IT

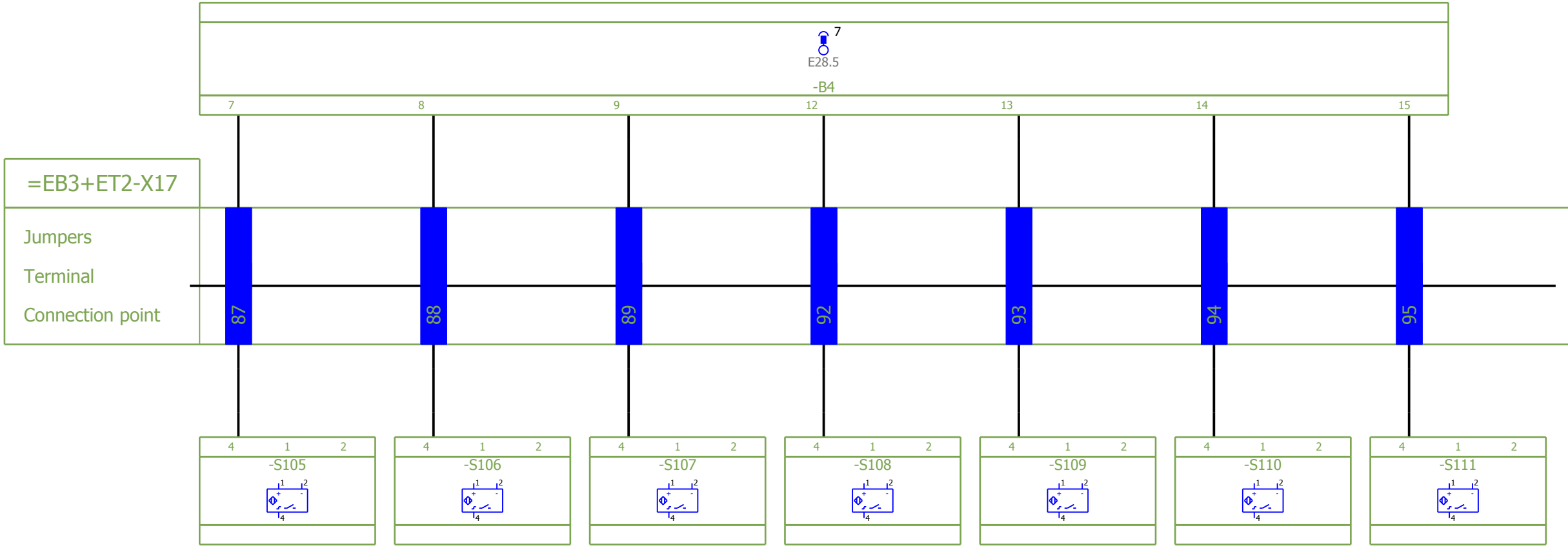

External targets

IT

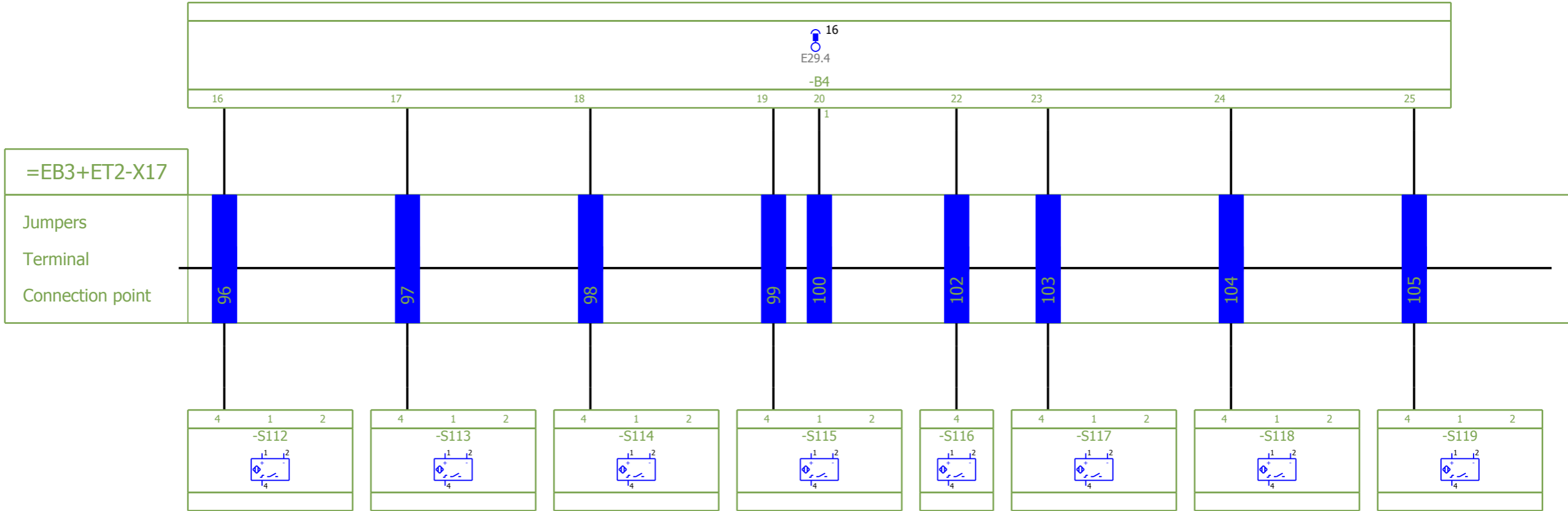

External targets

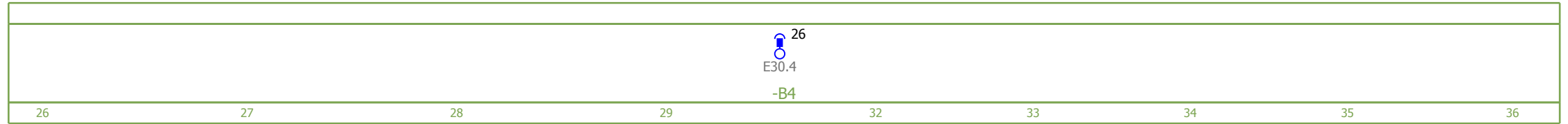

=EB3+ET2-X17  
Jumpers  
Terminal  
Connection point

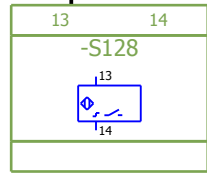
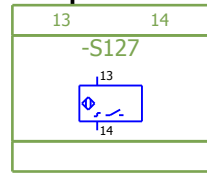
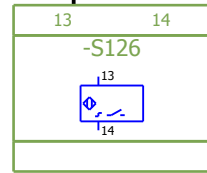
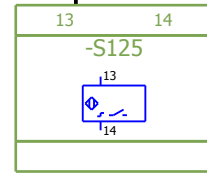
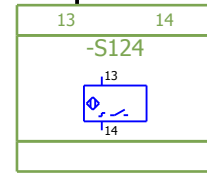
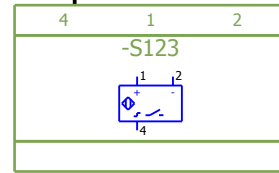
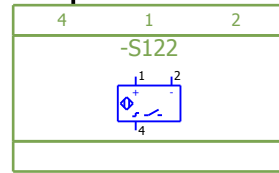
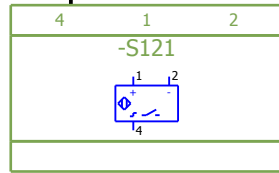
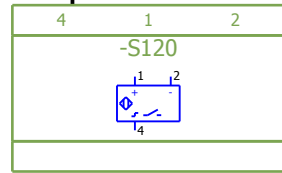
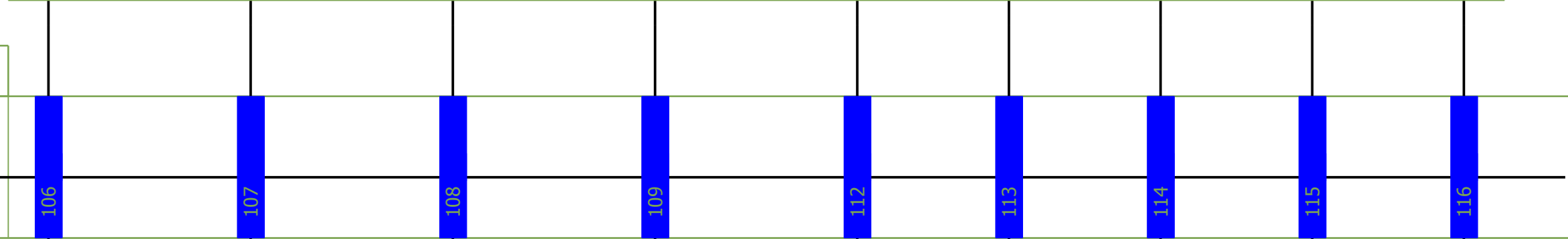

External targets



I

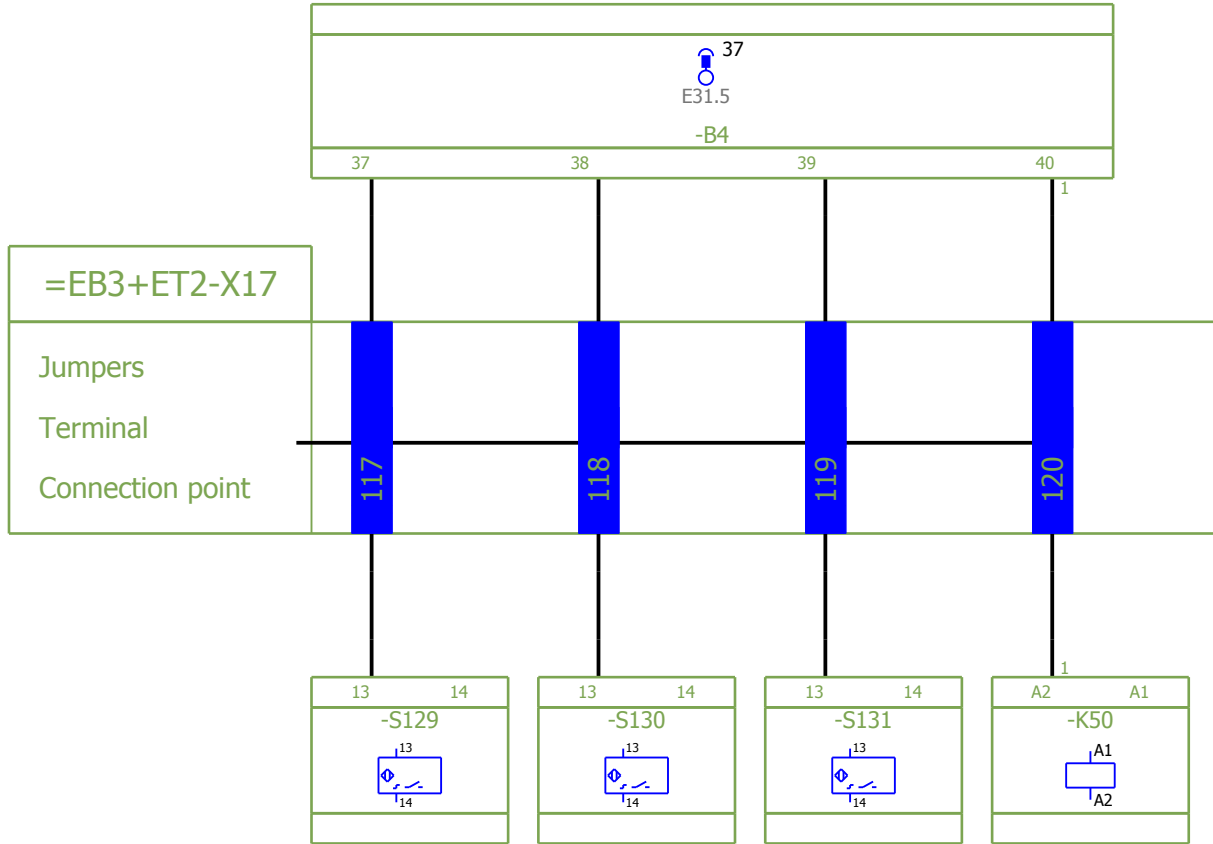

External targets

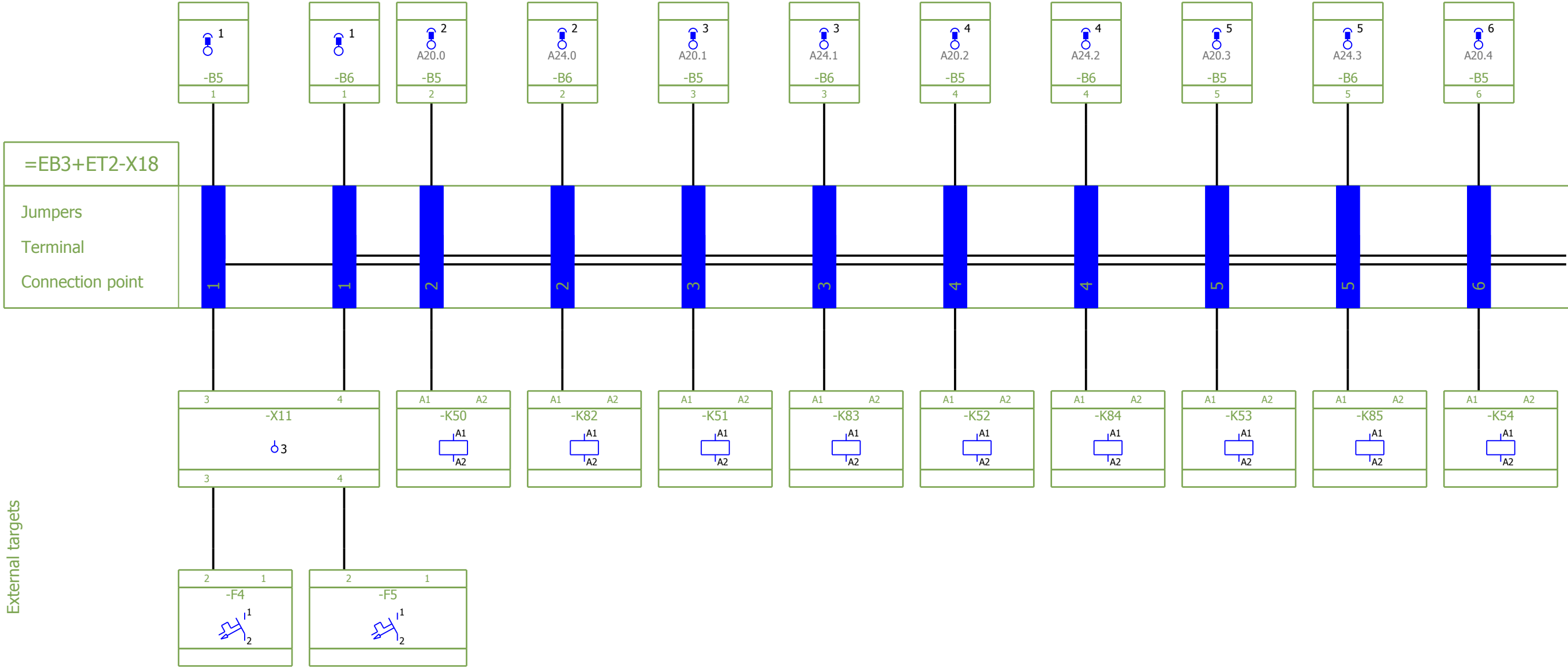

External targets

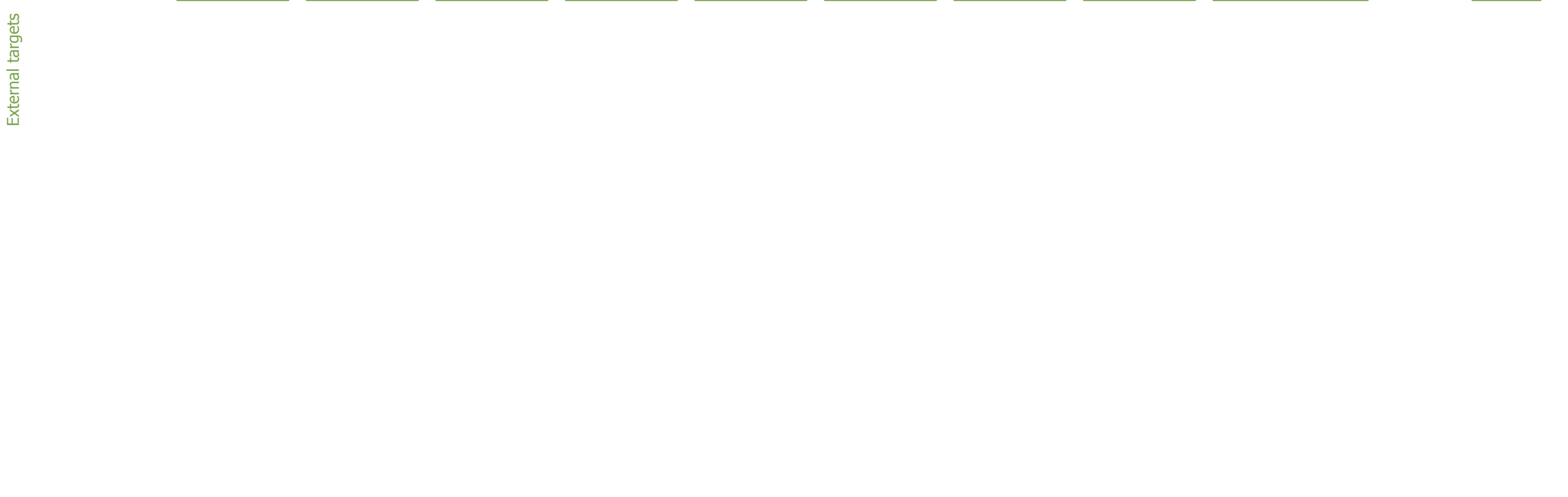
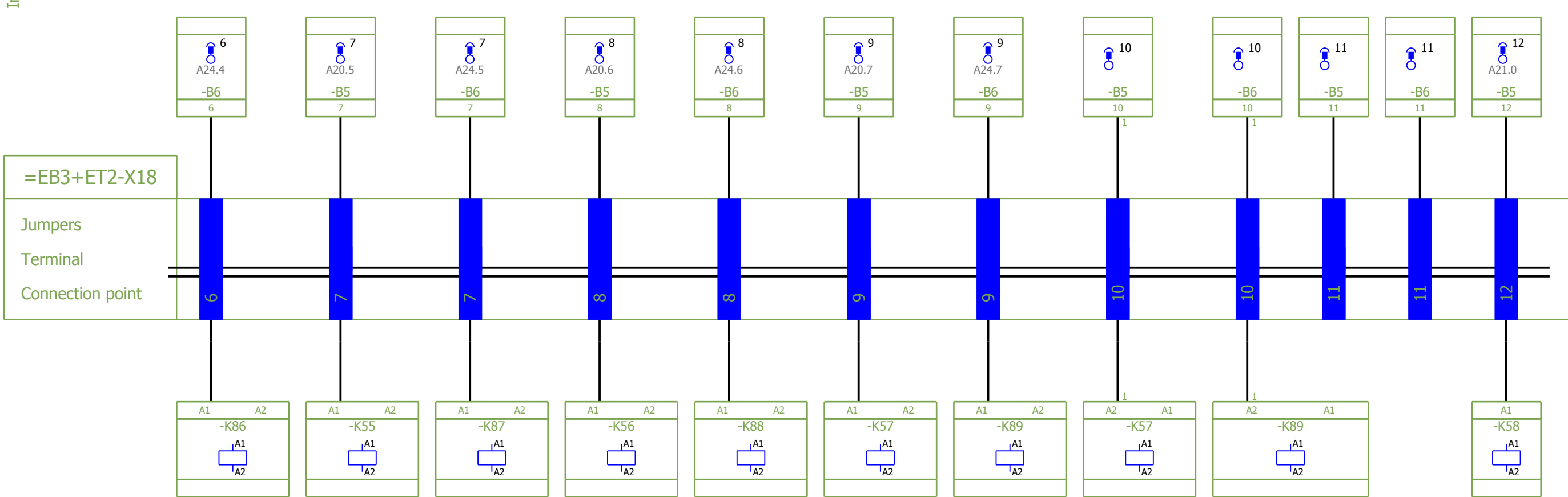

IT

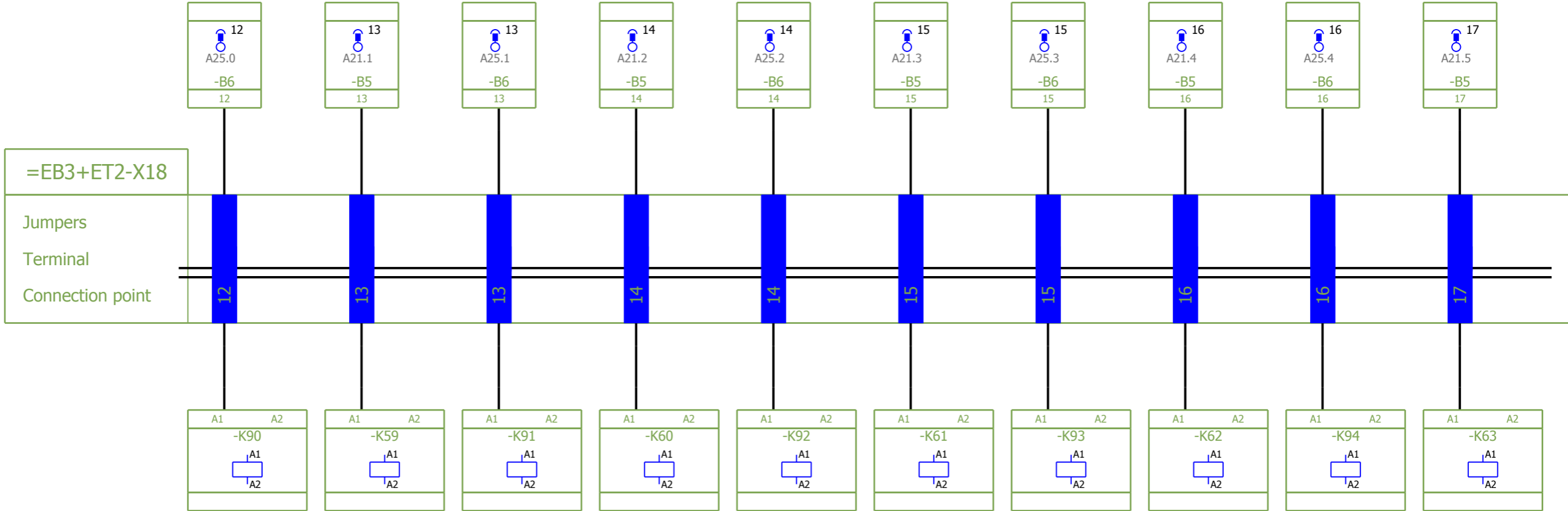

External targets

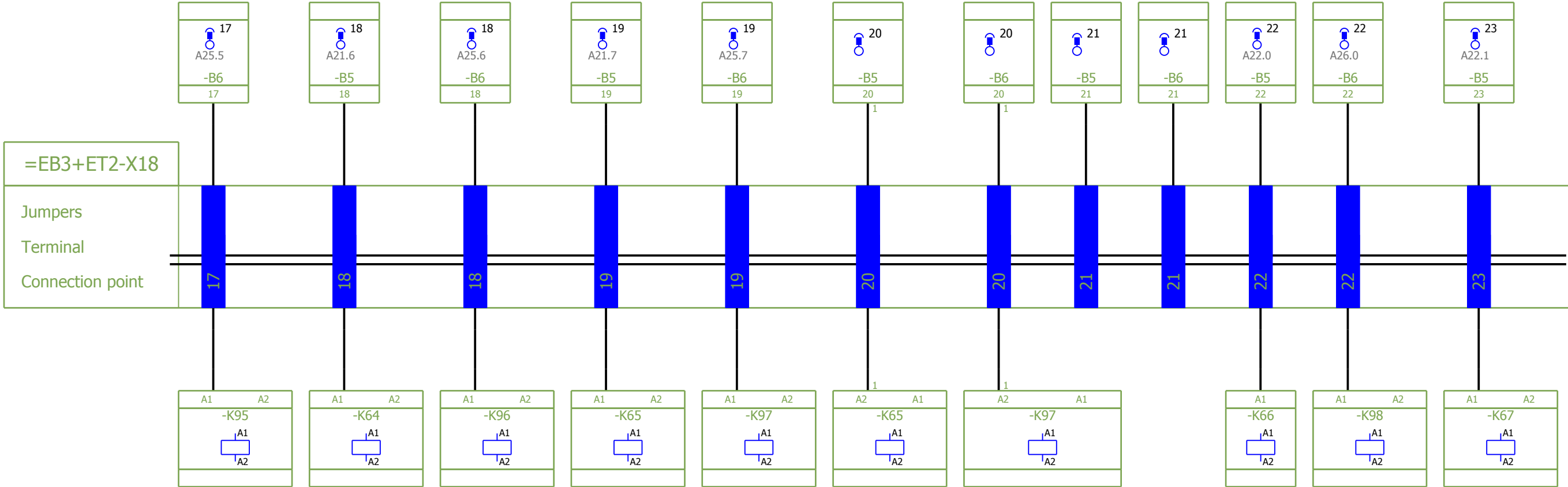

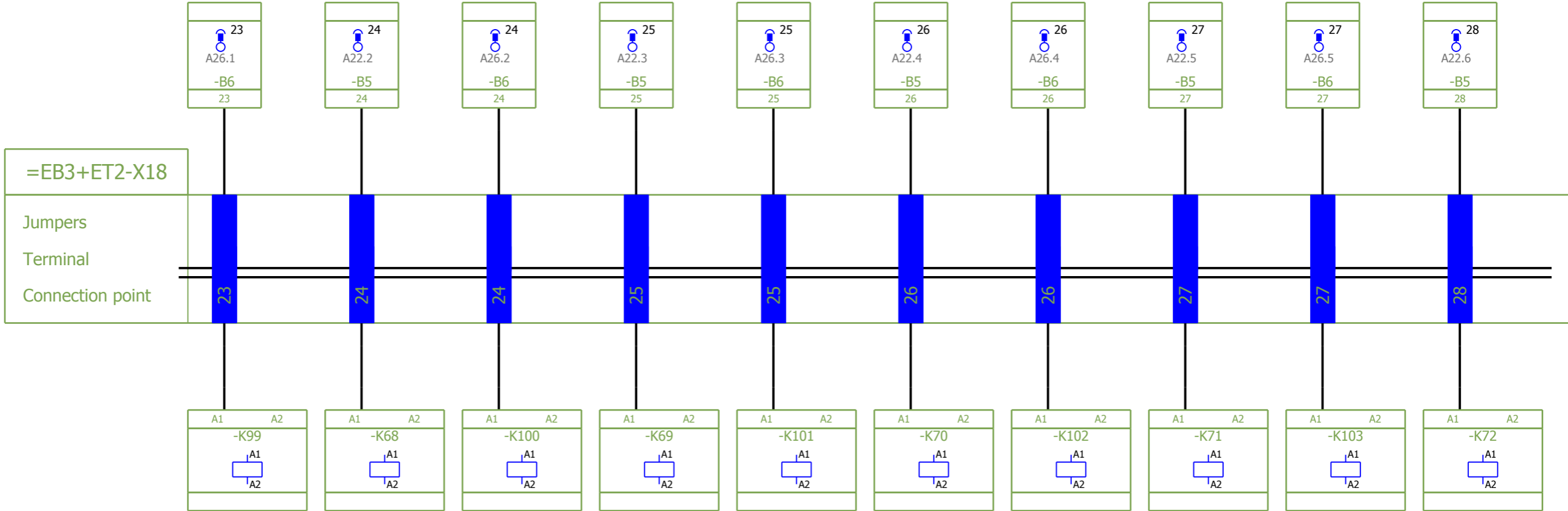

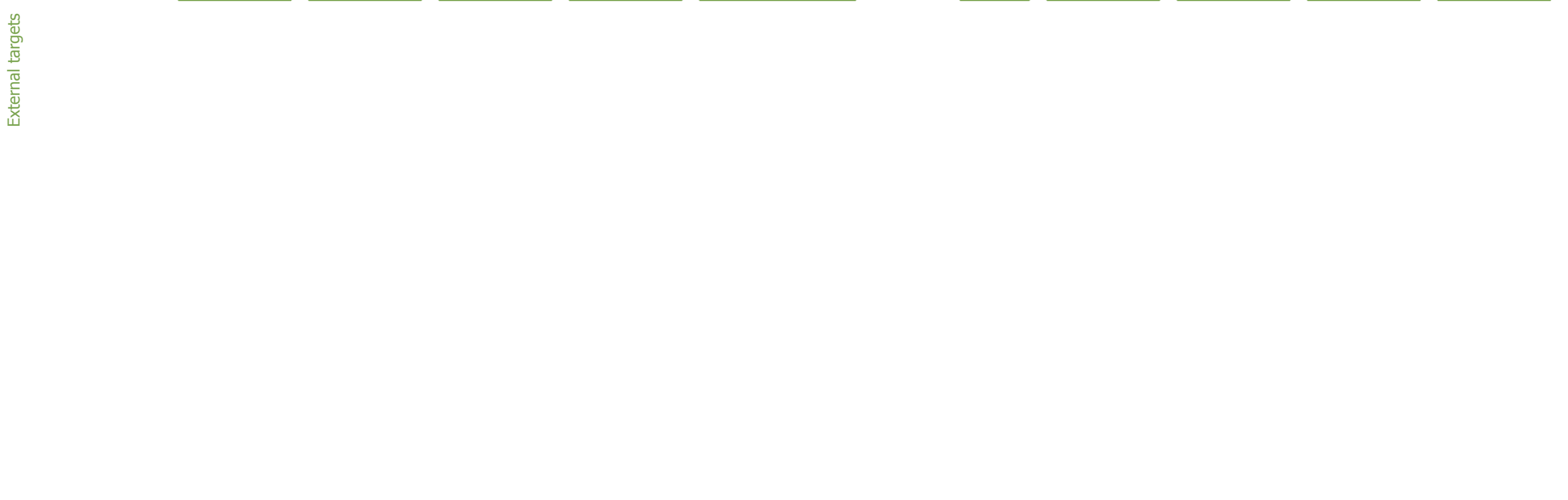
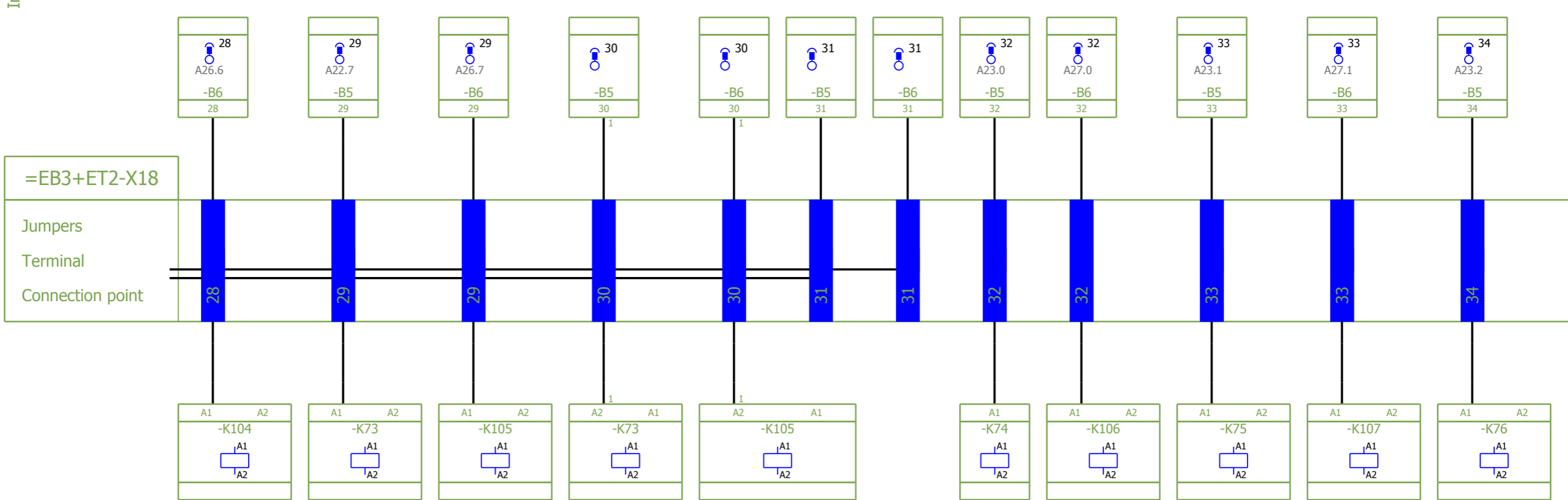

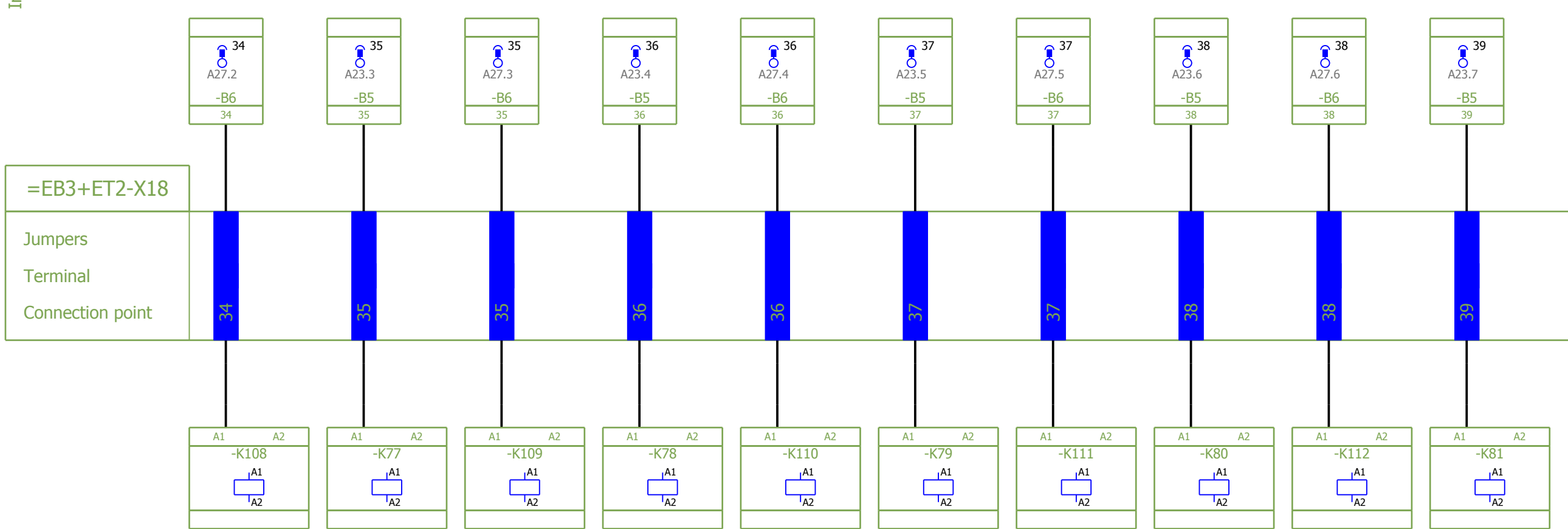

External targets



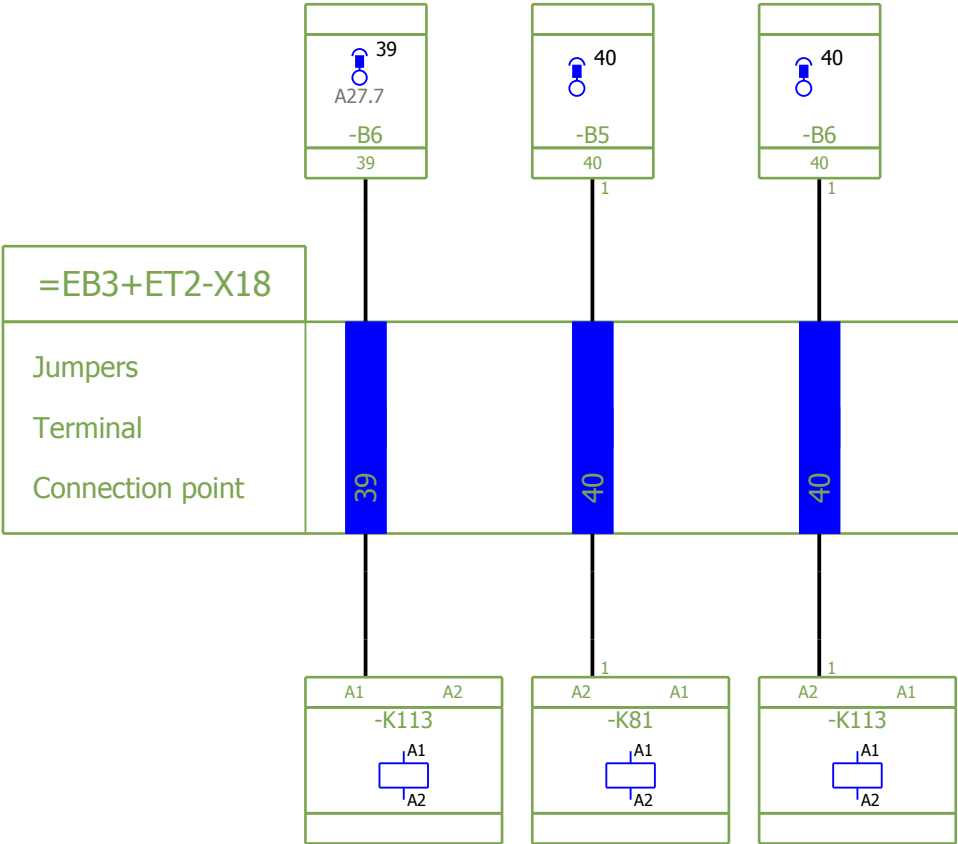

External targets

=EB3+EBS-T10	1	Resistance thermometer measuring transducer	MCR-PT100-I-DC	PXC	PXC.2810337
=EB3+EBS-T11	1	Resistance thermometer measuring transducer	MCR-PT100-I-DC	PXC	PXC.2810337
=EB3+EBS-T12	1	Resistance thermometer measuring transducer	MCR-PT100-I-DC	PXC	PXC.2810337
=EB3+EBS-T14	1	Resistance thermometer measuring transducer	MCR-PT100-I-DC	PXC	PXC.2810337
=EB3+EBS-T15	1	Resistance thermometer measuring transducer	MCR-PT100-I-DC	PXC	PXC.2810337
=EB3+EBS-T16	1	Resistance thermometer measuring transducer	MCR-PT100-I-DC	PXC	PXC.2810337
=EB3+EBS-T18	1	Resistance thermometer measuring transducer	MCR-PT100-I-DC	PXC	PXC.2810337
=EB3+EBS-T19	1	Resistance thermometer measuring transducer	MCR-PT100-I-DC	PXC	PXC.2810337
=EB3+EBS-TT22	1	Resistance thermometer measuring transducer	MCR-PT100-I-DC	PXC	PXC.2810337
=EB3+EBS-TT23	1	Resistance thermometer measuring transducer	MCR-PT100-I-DC	PXC	PXC.2810337
=EB3+EBS-TT24	1	Resistance thermometer measuring transducer	MCR-PT100-I-DC	PXC	PXC.2810337
=EB3+EBS-TT25	1	Resistance thermometer measuring transducer	MCR-PT100-I-DC	PXC	PXC.2810337
=EB3+EBS-TT26	1	Resistance thermometer measuring transducer	MCR-PT100-I-DC	PXC	PXC.2810337
=EB3+ET1-A0	1	CPU 315-2 PN/DP	6ES7315-2EH14-0AB0	SIE	SIE.6ES7315-2EH14-0AB0
=EB3+ET1-A1	1	SM 331, 8AI, 9/12/14BIT	6ES7331-7KF02-0AB0	Siemens AG	SIE.6ES7331-7KF02-0AB0
=EB3+ET1-A2	1	SIMATIC S7-300, analog output SM 332	S7	SIEMEN	SIE.6ES7332-5HF00-0AB0
=EB3+ET1-A3	1	SM 321, 32DI, DC 24V	6ES7321-1BL00-0AA0	Siemens AG	SIE.6ES7321-1BL00-0AA0
=EB3+ET1-A4	1	SIMATIC S7-300, digital input SM 321	S7	SIEMEN	SIE.6ES7321-1BH02-0AA0
=EB3+ET1-A5	1	SIMATIC S7-300, digital output SM 322	S7	SIEMEN	SIE.6ES7322-1BL00-0AA0
=EB3+ET1-F1	1	NEOZED fuse insert	S 6 A/380 V	PHÖNIX	PHO.0913032
=EB3+ET1-F2	1	Miniature circuit-breaker	5SX2102-8	SIEMEN	SIE.5SX2102-8
=EB3+ET1-F3	1	Miniature circuit-breaker	5SX2102-8	SIEMEN	SIE.5SX2102-8
=EB3+ET1-F4	1	Miniature circuit-breaker	5SX2102-8	SIEMEN	SIE.5SX2102-8
=EB3+ET1-F5	1	Miniature circuit-breaker	5SX2102-8	SIEMEN	SIE.5SX2102-8
=EB3+ET1-F6	1	Miniature circuit-breaker	5SX2102-8	SIEMEN	SIE.5SX2102-8
=EB3+ET1-F7	1	Miniature circuit-breaker	5SX2102-8	SIEMEN	SIE.5SX2102-8
=EB3+ET1-F8	1	Miniature circuit-breaker	5SX2102-8	SIEMEN	SIE.5SX2102-8
=EB3+ET1-F9	1	Miniature circuit-breaker	5SX2102-8	SIEMEN	SIE.5SX2102-8
=EB3+ET1-F10	1	Miniature circuit-breaker	5SX2102-8	SIEMEN	SIE.5SX2102-8
=EB3+ET1-F200	1	3-pole Neozed fuse 25A kpl.	3-polige Neozed-Sicherung 25A kpl.	SIEMEN	SIE.3-polige Neozed-Sicherung 25A
=EB3+ET1-KM1	1	Motor contactor	GJL1211001R0101	ABB	ABB.GJL1211001R0101
=EB3+ET1-KM2	1	Motor contactor	GJL1211001R0101	ABB	ABB.GJL1211001R0101
=EB3+ET1-KM3	1	Motor contactor	GJL1211001R0101	ABB	ABB.GJL1211001R0101
=EB3+ET1-KM4	1	Motor contactor	GJL1211001R0101	ABB	ABB.GJL1211001R0101
=EB3+ET1-KM6	1	Motor contactor	GJL1211001R0101	ABB	ABB.GJL1211001R0101
=EB3+ET1-KM7	1	Motor contactor	GJL1211001R0101	ABB	ABB.GJL1211001R0101
=EB3+ET1-KM8	1	Motor contactor	GJL1211001R0101	ABB	ABB.GJL1211001R0101
=EB3+ET1-KM9	1	Motor contactor	GJL1211001R0101	ABB	ABB.GJL1211001R0101
=EB3+ET1-KM10	1	Motor contactor	GJL1211001R0101	ABB	ABB.GJL1211001R0101
=EB3+ET1-KM11	1	Motor contactor	GJL1211001R0101	ABB	ABB.GJL1211001R0101
=EB3+ET1-KM12	1	Motor contactor	GJL1211001R0101	ABB	ABB.GJL1211001R0101
=EB3+ET1-KM13	1	Motor contactor	GJL1211001R0101	ABB	ABB.GJL1211001R0101
=EB3+ET1-KM14	1	Motor contactor	GJL1211001R0101	ABB	ABB.GJL1211001R0101
=EB3+ET1-KM15.A	1	Motor contactor	GJL1211001R0101	ABB	ABB.GJL1211001R0101
=EB3+ET1-KM15.B	1	Motor contactor	GJL1211001R0101	ABB	ABB.GJL1211001R0101
=EB3+ET1-KM16	1	Motor contactor	GJL1211001R0101	ABB	ABB.GJL1211001R0101
=EB3+ET1-KM17.A	1	Motor contactor	GJL1211001R0101	ABB	ABB.GJL1211001R0101
=EB3+ET1-KM17.B	1	Motor contactor	GJL1211001R0101	ABB	ABB.GJL1211001R0101
=EB3+ET1-M1	1	Three-phase motor	DV112M4	SEW	SEW.DV112M4
=EB3+ET1-M2	1	Three-phase motor	DV112M4	SEW	SEW.DV112M4
=EB3+ET1-M3	1	Three-phase motor	DV112M4	SEW	SEW.DV112M4
=EB3+ET1-M4	1	Three-phase motor	DV112M4	SEW	SEW.DV112M4
=EB3+ET1-M5	1	Three-phase motor	DV112M4	SEW	SEW.DV112M4
=EB3+ET1-M6	1	Three-phase motor	DV112M4	SEW	SEW.DV112M4
=EB3+ET1-M7	1	Three-phase motor	DV112M4	SEW	SEW.DV112M4
=EB3+ET1-M8	1	Three-phase motor	DV112M4	SEW	SEW.DV112M4

