

1 **Impact of anaerobic digestion and**
2 **centrifugation/decanting processes in**
3 **bacterial communities fractions**

4 **Short title: “Impact of anaerobic digestion in bacterial communities”**

5 Ana Isabel Díaz¹, Paula Oulego¹, Sergio Collado¹, Adriana Laca¹, J. Manuel González²
6 and Mario Díaz^{1*}

7 ¹Department of Chemical and Environmental Engineering, University of Oviedo, C/
8 Julián Clavería, s/n, Oviedo, E-33006, Spain

9 ² R&D, COGERSA SAU, C/ La Zoreda, s/n, Gijón, E-33697, Spain

10 *E-mail: mariodiaz@uniovi.es, Phone: +34 985 10 34 39, Fax: +34 985 10 34 34

11 **ABSTRACT**

12 Sewage sludge can be treated by anaerobic processes that frequently are followed by
13 physical separation processes. In this work, a high-throughput sequencing technology,
14 based on variation in the bacterial 16S rRNA gene, has been used to characterise the
15 bacterial populations present in samples taken from different points of an industrial
16 anaerobic digestion process fed with sewage sludge. Relative abundances of phyla and
17 classes throughout the biological process and the subsequent separation steps were
18 determined. Results revealed that the *Bacteroidetes*, *Firmicutes* and *Proteobacteria* phyla
19 were the most representative. However, significant changes in relative abundance were
20 detected along treatments, showing the influence of operational parameters on the
21 distribution of microorganisms throughout the process. After anaerobic digestion, phylum
22 *Firmicutes* doubled its relative abundance, which seems to indicate that the anaerobic
23 conditions and the nutrients favoured its growth, in contrast to other phyla that almost
24 disappeared. After centrifugation, *Proteobacteria* went preferentially to the solid phase,
25 in contrast to *Firmicutes* which was the dominant phylum in the liquid phase. After
26 decanting the liquid phase during 14 h, an important growth of *Proteobacteria*,
27 *Spirochaetes* and *Tenericutes* was detected. At class level, only significantly changes
28 were observed for *Proteobacteria* classes being α -*proteobacteria* dominant in the
29 digestate, while γ -*proteobacteria* was the majority since this point to the final steps. To
30 know the changes on the kind and abundance of microbial populations throughout the
31 anaerobic and separation processes is very important to understand how the facilities
32 design and operation conditions can influence over the efficiencies of next biological
33 treatments.

34 **KEYWORDS**

35 16S rRNA gene; anaerobic digestion; PGM sequencing; bacterial community; separation
36 processes; sewage sludge.

37 INTRODUCTION

38 The anaerobic processes take place in four stages: hydrolysis, acidogenesis, acetogenesis
39 and methanogenesis. The microorganisms of two biological domains, Bacteria and
40 Archaea, carry out interdependent and complex biological reactions during the process.
41 Bacteria microorganisms produce enzymes which hydrolyze polymers to monomers.
42 These are subsequently converted by acidogenic and acetogenic bacteria to H₂ and
43 volatile fatty acids (1). The Archaea domain is mainly involved in the last stage, forming
44 methane by the reduction of CO₂ or by the decarboxylation of acetate. Microorganisms
45 within this domain can also utilize a limited number of other substrates, such as methanol,
46 methylamines and formate, to produce methane (2).

47 Anaerobic digestion is the most widely employed method for sewage sludge treatment,
48 and since the last years, it is an attractive technology for processing various organic
49 wastes produced in urban, industrial, and agricultural settings (3). In this process, a large
50 fraction of the organic matter, which is degraded by a complex community of
51 microorganisms, is broken down into carbon dioxide (CO₂) and methane (CH₄). Such
52 decomposition occurs in the absence of oxygen and two main final products can be
53 distinguished: digestate and biogas, which is considered a product of high added value to
54 be used as biofuel in a sustainable and environmentally friendly way (4). After the
55 anaerobic digestion, the digestate can be treated to remove liquid fraction and
56 simultaneously concentrate nutrients, so a solid–liquid phase separation is usually carried
57 out prior to any further post-treatment. The solid fraction mixed with vegetable wastes, is
58 mainly used in composting processes to be employed as a fertilizer (5).

59 Regarding the liquid fraction, depending on substrates used and final disposal, a
60 biological post-treatment could be necessary to reduce its toxicity and nitrogen content.

61 Microorganisms play a main role in anaerobic digestion treatments, so it is essential to
62 characterize the microbiota at each stage of the process in order to detecting the core
63 functional groups responsible of anaerobic degradation and key for the further post-
64 treatment. The substrate characteristics and operational parameters are determining
65 factors for the stability of the microbial communities.

66 Previous studies describing the microbial communities employing methods such as
67 terminal restriction fragment length polymorphism (T-RFLP), denaturing gradient gel
68 electrophoresis (DGGE), single-strand conformation polymorphism (SSCP), or Sanger
69 sequencing of clone libraries (3, 6).

70 Just few years ago, the next generation of sequencing (NGS) based on 16S rRNA gene
71 sequencing has been applied to characterize anaerobic digestion processes. This
72 technology allows the generation of thousands to millions of short sequencing reads for
73 massive studies of genes and a higher taxonomic resolution (7). Most of such works
74 investigated only a few hypervariable regions, mainly V3, V4 and V5, so the phylogenetic
75 and taxonomic information obtained was limited. In this study, 7 of the 9 hypervariable
76 regions of the 16S rRNA gene have been sequenced to obtain extensive phylogenetic
77 information by using the Ion Torrent PGM system of mass sequencing.

78 The microbiota present in anaerobic processes has been studied by several authors as
79 Chen et al (8) which studied the microbiota present in a anaerobic digestion of
80 pharmaceutical wastewater and Zhou et al (9) which showed the variation of the microbial
81 community in thermophilic anaerobic digestion of pig manure mixed with different ratios
82 of rice straw.

83 However, as far as we know, the evolution of the microbial population throughout the
84 anaerobic digestion of sludge and the subsequent separation processes, i.e. centrifugation

85 and decanting, have not been previously studied. Obviously, changes in microbiota
86 distribution, especially in their relative abundance and activity, are ultimately reflected in
87 the reactor performance and the efficiency of following biological treatments, where the
88 bacteria also play an important role.

89 In particular, the aims of this work were: i) To characterize the bacterial population in the
90 anaerobic digestion process and compare the results with the microbiota present in raw
91 material. ii) To study the distribution of the bacterial communities between the separated
92 fractions to determine the effect of the separation processes as centrifugation and
93 decanting.

94 **MATERIALS AND METHODS**

95 *Plant operation parameters and sample description*

96 The samples used in this study were taken from the anaerobic digestion plant sited the
97 waste treatment centre, COGERSA (Asturias, Spain).

98 Anaerobic digestion process was conducted with mixed sludge, sludge (primary and
99 activated sludge) that has been dehydrated by centrifugation or press filter. Previously to
100 the digestion, the sewage sludge was received in two concrete pits, each one with an
101 operational capacity of 175 m³. The sludge was pumped from these pits to a mixer, where
102 the sludge is mixed with recirculated process water, in a ratio of 1: 1.2 (v/v), respectively.
103 This raw mixture was stirred for 60 minutes. This treatment was carried out in order to
104 disintegrate the biodegradable waste for improving the subsequent digestion process and
105 removing the non-biodegradable contaminants, such as the heavy fraction (stones, large
106 bones, glass, batteries and metal objects) and the light one (textiles, wood, plastic sheets
107 and thread, etc.). The mixture was sent to the Grit Removal System (GRS) consisting of
108 three hydro-cyclones connected in cascade for removing any sand or impurities that might

109 remain in the suspension. All impurities removed were sent to the reject container.
110 Finally, it was stored in a 1000 m³ capacity tank to enable continuous feeding to the
111 digester.

112 The anaerobic digestion process was carried out in two anaerobic completely stirred tanks
113 with a total capacity of 6000 m³, under mesophilic conditions (36 ± 0.6°C). The digester
114 was heated up by means of external heat exchangers. Proper mixing system inside the
115 digester was achieved by injecting part of the produced biogas through an air-cooled
116 rotary vane compressor. The plant produces around 50000 m³/week of biogas with 64%
117 of CH₄.

118 After anaerobic digestion process, biogas and digestate was obtained. The biogas was
119 extracted and leaded to the general biogas network of the landfill. The digestate was
120 separated in solid and liquid phase using an industrial centrifuge at 3000 rpm. The
121 percentage of solid and liquid phase obtained was around 20% and 80% of the incoming
122 digestate, respectively. For this process, it was necessary the addition of a polyelectrolyte
123 (Chemipol CZ-600) in a concentration of 0.35% (v/v). The solid phase was sent to a
124 composting plant and the liquid phase was decanted for 45 hours in an open tank with a
125 volume of 80 m³, before being sent to the biological subsequent treatment. Occasionally,
126 some biodegradable-organic effluents from other treatments carried out in the waste
127 treatment centre are spilled into the decanter. The volume is always lower than 10% of
128 the incoming water flow. A flow diagram of the treatment plant is shown in Figure 1.

129 **FIGURE 1**

130 ***Sample processing and DNA extraction***

131 Different samples were collected in the anaerobic digestion plant in order to be analysed
132 microbiologically. Such samples were the following: the feed to the anaerobic digester

133 (S1), the digestate (S2), the solid fraction (S3) and the liquid fraction (S4) obtained after
134 centrifugation and the liquor obtained after decanting (S5). Detailed information for each
135 sample is shown in Table 1.

136 TABLE 1

137 In all cases, 160 ml of each of the samples were centrifuged for 20 minutes at 13000g.
138 The supernatant was discarded, and the solid fraction was preserved for DNA extraction.
139 DNA extraction was performed with the Power Biofilm DNA Isolation Kit (MoBio
140 Laboratories, Inc., Carlsbad, CA), which is specific for sludge samples. The extraction
141 was carried out with 0.25 g of wet sludge (solid fraction) according to the manufacturer's
142 instructions. The only modification was the addition of 200 µl of solution BF3 due to the
143 excessive colour of the samples (recommended in the protocol of the kit).

144 Extracted DNA was concentrated using Concentrator Plus Vacufuge® (Eppendorf,
145 Germany) and the concentrations were determined through the BioPhotometer Plus
146 (Eppendorf, Germany), ensuring that the amount of DNA was high enough to continue
147 the process.

148 ***DNA amplification and purification***

149 For DNA amplification, Ion 16S Metagenomics Kit (Ion Torrent, Life Technologies) was
150 employed. This kit simultaneously examines 7 of the 9 hypervariable regions in the
151 bacterial 16S rRNA gene, using one primer for the V2-4-8 regions and another primer for
152 V3-6 and V7-9. This method has a wide range of uses, including the characterization of
153 bacterial populations, taxonomical analysis, and species identification.

154 The DNA samples and the primers with their respective linkers were amplified by PCR
155 reaction, which was performed in several steps: i) initial heating at 95 °C for 10 minutes,
156 ii) 25 cycles of denaturation at 95 °C for 30 seconds, iii) alignment at 58 °C for 30

157 seconds, iv) extension at 72 °C for 30 minutes seconds, and v) elongation at 72 ° C for 7
158 minutes. Next, a preservation step at 4 °C for 20 minutes was carried out. The resulting
159 products were purified using the Agencourt AMPure XP Kit (Beckman Coulter, USA)
160 and finally the 16S rRNA amplicons were quantified through Qubit® 2.0 Fluorometer
161 using dsDNA HS Assay Kit (Invitrogen, USA).

162 *Library construction and sequence analysis*

163 Once the DNA was purified, the sequencing step was performed. First, the library was
164 prepared using the Ion Plus Fragment Library Kit (AB Library Builder™). During this
165 process, the fragmentation of the DNA obtained in the purification phase was carried out
166 in order to obtain smaller fragments of up to 150 base pairs (bp). For the library
167 construction, each fragment of the DNA obtained was coupled to a marker or barcode and
168 two adapters. Each library corresponds to a different collection of DNA fragments to be
169 sequenced and is unique to each sample. Construction of the library was conducted using
170 the PGM™ Hi-Q™ OT2 Kit. Subsequently, the samples were sequenced using the
171 PGM™ Hi-Q™ Sequencing Ion Kit and the Ion 318™ Chip Kit v2, which has a minimum
172 capacity of 4 million readings.

173 The final results obtained were analysed with Life Technologies Ion Reporter™ Software,
174 which provided the final sequencing results. The restriction criteria applied, was as
175 follows: i) read length filter: 150 bp, ii) minimum alignment coverage: 90%, iii) read
176 abundance filter: 10, iv) genus cut off (level of coincidence to determine gender): 97%,
177 and v) species cut off (level of coincidence to determine species): 99%.

178 **RESULTS AND DISCUSSION**

179 PGM sequencing and the amplification of hypervariable regions of 16S rRNA allowed us
180 to obtain a detailed taxonomic bacterial classification. Twenty-one different phyla were

181 identified in the samples. The classification of the microorganisms up to specie level is
182 shown in Fig.S1 to Fig.S5. Taxonomic classification is represented by Krona plot, which
183 depicts different bacteria taxonomic levels in concentric circles, from subspecies in the
184 outermost circle to the bacteria kingdom in the innermost circle. The relative abundance
185 of bacterial phyla was estimated in each sample as the percentage of mapped reads.

186 The phyla *Firmicutes*, *Bacteroidetes* and *Proteobacteria* were the more representative in
187 all the samples. Nelson et al (10) and Sundberg et al (11) found in samples taken from
188 anaerobic processes the cited phyla and also *Chloroflexi* and *Actinobacteria*.

189 In this work, *Actinobacteria*, and *Chloroflexi* were detected, but with relative abundances
190 below 15% and 1%, respectively, in contrast to data reported in other anaerobic digestion
191 processes (12, 13).

192 Finally, other phyla as *Synergistetes* and *Thermodesulfobacteria* were also detected in all
193 analysed samples, although in low concentrations.

194 **Anaerobic digestion process**

195 The mixture fed to the digester (S1) and the digestate (S2) were analysed. Fig.2.A,
196 presents the relative abundance of the different phyla in the initial mixture (S1) fed to the
197 anaerobic digester.

198 **FIGURE 2**

199 In sample S1, that contains the pretreated sludge mixed with the recirculation, *Firmicutes*
200 was the majority phylum representing 41% of the total abundance. Its presence has been
201 reported by several authors as one of the most abundant phyla in anaerobic digestion
202 processes (14, 15, 16). During the hydrolysis, the complex molecules are broken down
203 into simpler ones. This phylum is related to the production of extracellular enzymes with
204 cellulases, lipases or proteases (17). Therefore, a high relative abundance of this phylum

205 in S1 is an advantage for the subsequent anaerobic digestion process. The recirculation
206 of the clarified during the sludge treatment is an important aspect that can influence
207 significantly in the relative abundance of each phylum in the anaerobic reactor. In this
208 case, *Firmicutes* is present in the recirculation (S4, see Fig.3B), contributing to its high
209 relative abundance in S1. Zamanzadeh et al (12) studied the microbial communities
210 present in mesophilic and thermophilic anaerobic digesters, with and without
211 recirculation. The study showed that phylum *Firmicutes* was dominant in processes with
212 recirculation and the phylum *Chloroflexi* was dominant in processes without
213 recirculation. This last phylum was identified in this work with a relative abundance lower
214 than 1% in all samples.

215 The phyla *Bacteroidetes*, *Proteobacteria* and *Spirochaetes*, which are associated with
216 fermentative metabolism of macromolecular organic compounds, represent 19%, 15%
217 and 15% of the total abundance in S1, respectively (18).

218 The phylum *Bacteroidetes* is composed of gram-negative bacteria which are specialist for
219 the degradation of high molecular weight organic matter to acetic and propionic acid (19).
220 This phylum has been frequently detected in anaerobic reactors loaded with sludge,
221 vegetal biomass or mixed organic residues (20, 21).

222 *Proteobacteria* and *Spirochaetes* phyla contain anaerobic and aerobic bacteria, and they
223 are associated with hydrolysis, acidogenesis and acetogenesis reactions in anaerobic
224 digestion processes (22). Within *Proteobacteria* phylum, order *Syntrophobacterales* was
225 detected. Some bacteria belonging to this order are known for its syntrophic acetogenesis
226 activity, especially due to its propionate-oxidizing capacity. Syntrophic acetogenesis is a
227 crucial step to maintain stable the anaerobic digestion because high concentrations of
228 propionate inhibit methanogenesis (2). Also, genus *Paracoccus*, *Hyphomicrobium*,

229 *Comamonas* and *Nitrosomonas* were detected. These bacteria are also characterized for
230 its nitrifying and denitrifying activity, which may greatly contribute to the nitrogen
231 removal.

232 Other phyla as *Tenericutes*, *Actinobacteria* and *Synergistetes* do not exceed 5% of the
233 total abundance which is in accordance to results obtained in other studies for similar
234 samples (15, 23).

235 Fig.2B, presents the relative abundance of the different phyla in the digestate after
236 anaerobic digestion (S2). Results showed that an important variation occurs in the
237 microbiota during the process. The phylum *Firmicutes* increases severely reaching 83%
238 of total abundance. On the opposite, *Bacteroidetes* and *Proteobacteria* decreased
239 drastically below 10%. In the case of *Spirochaetes*, almost the disappearance of the
240 phylum occurred during the anaerobic process.

241 The majority of microorganisms who belong to *Firmicutes* phylum are mesophilic, so
242 its growth was favoured at 36°C. Its predominance in the S2 sample showed a correct
243 functioning of the digester. The presence of *Bacteroidetes* phylum is also closely related
244 with operating temperature, decreasing their relative abundance with the increase in
245 operating temperature (24). *Proteobacteria* and *Spirochaetes* were reduced in the
246 digestate because of the absence of oxygen during the anaerobic process (1).

247 With respect to the classes, five different classes were detected within the phylum
248 *Proteobacteria* in S1 and S2: δ -*proteobacteria*, ϵ -*proteobacteria*, α -*proteobacteria*, β -
249 *proteobacteria*, and γ -*proteobacteria* (see Fig.2)

250 After anaerobic digestion, in the digestate (S2), the α -*proteobacteria* class significantly
251 increased their relative abundance reaching values higher than 50%, while β -
252 *proteobacteria* and γ -*proteobacteria* classes decreased. The α -*proteobacteria* class

253 include mainly fermentative anaerobic bacteria, while *β-proteobacteria* and *γ-*
254 *proteobacteria* classes contain aerobic bacteria, so the anaerobic conditions limited the
255 viability of these microorganisms. Previous studies described *α-proteobacteria* as
256 predominant class in mesophilic digesters while *γ-proteobacteria* was dominant in
257 thermophilic digesters (11). Pervin et al (25) detected *β-proteobacteria* as dominant class
258 in a thermophilic reactor, especially genus *Comamonas* that can metabolise a wide variety
259 of organic acids.

260 For *Firmicutes* and *Bacteroidetes* phyla, no significant changes were detected in the
261 distribution of the classes after anaerobic treatment (Fig.2B).

262 Within *Firmicutes* phyla in S1 sample, *Clostridia* was the most abundant class,
263 represented mainly for the *Clostridial* order. Bacteria of the genus *Clostridium* are strict
264 anaerobes, typical in biogas plants, which have the capacity of producing hydrogen (26).
265 Many species of *Clostridia* class had been defined as typical anaerobic cellulolytic
266 bacteria. Areas of strong degradation in cellulose structures with these bacteria occupying
267 these depressions had been reported (27). Michalke et al (28) have reported that
268 microorganisms belonging to *Clostridia* class and sulphate-reducing bacteria are
269 producers of trimethylarsines and small amounts of arsine in sewage sludge digestion.
270 These compounds are considered with environmental risks because of their toxicity. Guo
271 et al (29) have described that this class performed the acidogenic process at the second
272 stage and produced VFA, CO₂ and H₂.

273 Jaenicke et al (30) carried out metagenomic studies during the anaerobic digestion of a
274 mixture of maize silage, green rye and chicken manure. Results showed that *Clostridia*
275 populations were in syntrophic association with hydrogenotrophic methanogens. For this

276 reason, the presence of this class supposes an advantage to maintain efficient biogas
277 production.

278 For the digestate (S2), the *Bacilli* and *Clostridia* classes represented 19% and 80%
279 respectively; increasing their relative abundance compared with other classes as
280 *Erysipelotrichi*, *Erysipelotrichia* and *Negativicutes* which have hydrolytic properties.

281 The class *Bacilli*, was mainly represented by the order *Lactobacillales*, where the family
282 of the *Carnobacteriaceae*, which contains bacterial species for decomposing fat and
283 carbohydrate, supposed more than 90% (31).

284 For *Bacteroidetes* phylum, the class *Bacteroidia* was the most representative in both
285 samples (S1 and S2), previously reported as the most abundant in mesophilic reactors.

286 This class play an important role in hydrolyzing and fermenting organic materials and
287 producing organic acids, CO₂ and H₂ during the anaerobic digestion process (29). The
288 relative abundance found for other classes as *Flavobacteria* and *Sphingobacteria* were
289 lower in comparison with other studies that reported these classes as dominant (32).

290 **Separation process I: Centrifugation**

291 The data obtained for the solid phase (S3) and the clarified (S4) resulting after the
292 centrifugation process are shown in Fig.3.

293 **FIGURE 3**

294 With respect to the centrifuge feed (S2), in the solid phase (S3), the abundance of the
295 phylum *Firmicutes* decreased to a value of 57%. On the opposite, the phylum
296 *Proteobacteria* increased its abundance reaching a value of 31%. Therefore, it can be
297 concluded that bacteria belonging to the phylum *Proteobacteria* have a greater tendency
298 to be removed by centrifugation. Yi et al (33) studied the effect of total solids
299 concentration on microbial communities involved anaerobic digestion processes of food

300 waste and, in agreement with our results, reported an increase in *Proteobacteria*
301 abundance for higher solid concentrations.

302 After the centrifugation process, sample S3 is mixed with vegetable wastes and sent to a
303 composting process. *Proteobacteria* and *Firmicutes*, between others, are able to
304 synthesize enzymes that catalyse the hydrolysis of plant polymers (34). For this reason,
305 the high abundance of these phyla in S3 is an advantage for the subsequent composting
306 process.

307 In the clarified (S4) important variations were not observed compared to the digestate
308 (S2). It should be noted that the majority of *Firmicutes* microorganisms from the digestate
309 were preserved in the liquid fraction after the centrifugation process.

310 Gao et al (35) studied the microbial populations in a bioreactor fed with sludge mixed
311 with sewage from cat food and they reported high relative abundance of the phylum
312 *Firmicutes* in the bioreactor suspension, as occurs here in the clarified (S4). This fact,
313 together with the recirculation of sample S4 during the sewage sludge treatment,
314 contributes to a correct operation of the anaerobic reactor.

315 With respect to the classes, in the solid phase (S3), γ -*proteobacteria* represented the 90%
316 of relative abundance, within *Proteobacteria* phylum, being the predominant families
317 *Pseudomonadaceae* and *Xanthomonadaceae*. This class showed a greater ability to be
318 removed by centrifugation than the β -*proteobacteria* and the α -*proteobacteria* classes
319 whose abundances were higher in the clarified (S4). This fact may be due to a lower
320 interaction of the β -*proteobacteria* and the α -*proteobacteria* with the polyelectrolyte
321 added for the centrifugation process and a lower tendency to the form flocs.

322 De Gannes et al (36) studied microbiota diversity in composts employing 454-
323 pyrosequencing, and they observed that γ -*proteobacteria* was especially abundant in the

324 mesophilic stage, whereas during thermophilic and mature stages *α-proteobacteria* and
325 *γ-proteobacteria* classes were more abundant. The high relative abundance of *γ-*
326 *proteobacteria* class in S3 sample, may be important in favour of the initial phase of
327 composting.

328 With respect to *Firmicutes* phylum, 6 different classes were detected in solid phase and
329 clarified samples (S3 and S4), i.e. *Bacilli*, *Clostridia*, *Erysipelotrichi*, *Erysipelotrichia*,
330 *Negativicutes* and *Thermolithobacteria* (Fig.3).

331 Significant differences in the relative abundances were not observed compared with
332 digestate. The class *Clostridia* was again the most representative and, as previously
333 commented, these bacteria are known to metabolize relatively recalcitrant materials such
334 as cellulose and lignin. In addition, species of *Bacilli* are known to secrete catabolic
335 enzymes, such as proteases (37). Therefore, the presence of these classes in the S3 sample
336 is convenient for the subsequent composting process.

337 Similarly to *Firmicutes* phylum, the distribution of the classes within phylum
338 *Bacteroidetes* was not affected by the centrifugation process and *Bacteroidia* was again
339 the predominant class.

340 **Separation process II: Decanting**

341 The results obtain for the decanted supernatant (S5) are shown in Fig. 4. After the
342 decanting process a great variety of phyla were detected, whose distribution varies
343 significantly in comparison with the liquid before decanting (S4).

344 **FIGURE 4**

345 The phylum *Firmicutes* was reduced to 37% of total abundance. On the contrary, other
346 phyla such as *Bacteroidetes*, *Proteobacteria*, *Spirochaetes* or *Tenericutes* increase their
347 total abundance reaching values of 10%, 37%, 8% and 6% respectively.

348 To understand these change, it is important to take into consideration that the decanting
349 process takes place into an open tank during 45 h as previously commented, in S4,
350 *Clostridia* was the class most abundant and these bacteria are strict anaerobes, thus it is
351 expectable that, during decanting step, its concentration decrease, being replaced for other
352 aerobic or facultative microorganisms.

353 The composition of relative abundance for the classes belonging to *Bacteroidetes* and
354 *Firmicutes* phyla were almost not affected by the decanting being again *Bacteroidia* and
355 *Clostridia* classes the most representative respectively. These classes contain well-known
356 fermentative bacteria which are closely involved in degradation of organic materials and
357 volatile fatty acids. Their presence is potentially associated with hydrolysis in wastewater
358 treatment plant (38).

359 The phylum *Proteobacteria* was the most affected by decantation, with an increase of the
360 γ -*proteobacteria* class and a drastic decrease of the α -*proteobacteria* class. The α -
361 *proteobacteria* class is mostly anaerobic microorganisms, so the decanting process in an
362 open tank for almost 2 days compromises their survival. On the contrary, the class of γ -
363 *proteobacteria* includes groups of aerobic bacteria that can grow during this process, as
364 *Pseudomonas*. The high relative abundance of γ -*proteobacteria* is important since these
365 microorganisms together with β -*proteobacteria* class, as *Nitrosomonas* bacteria, play a
366 crucial role in biological treatment processes as nitrification-denitrification (38), which is
367 the final destination of the decanted product.

368 In conclusion, the study indicated that the methodology employed, based on PGM
369 sequencing and the amplification of all variable regions of the 16S gene allowed us to
370 obtain an exhaustive taxonomic classification of bacterial populations throughout the
371 processes considered. The main phyla detected throughout the digestion, centrifugation

372 and decanting processes corresponded with microorganisms previously identified in
373 anaerobic digestion of sludge. However, the relative abundance for the phyla throughout
374 the process was very different depending on the treatment phase.

375 In the digestate (S2) from anaerobic digestion, *Firmicutes* was the predominant phylum,
376 constituted mainly by bacteria of the genus *Clostridia* followed by the genus *Bacilli*. Their
377 presence was crucial for a correct development of the anaerobic process. In related to
378 class level, only important variation was observed within *Proteobacteria* phylum where
379 *α-proteobacteria* was the most abundant after the process.

380 The relative abundance of the phyla in the clarified (S4) from centrifugation was very
381 similar to that found in the digestate (S2) and only a light decreasing of *Actinobacteria*
382 phylum was detected. This may be an advantage due to the recirculation of S4 sample to
383 the initial phase of anaerobic digestion. On the contrary, *Firmicutes* showed a sharp
384 decrease in the solid phase (S3), while the phylum *Proteobacteria* increased. This fact
385 indicates the different predisposition of these microorganisms to be removed by
386 centrifugation. *Proteobacteria* classes were again the most affected by the process being
387 *γ-proteobacteria* the dominant one.

388 Finally, after the decanting process, in the supernatant (S5), it was observed an increase
389 in the relative abundance of phyla that were minority in the clarified from the
390 centrifugation step (S4), especially the phyla *Proteobacteria*, *Spirochaetes* and
391 *Tenericutes*. On the other hand, *Firmicutes* phylum suffered a sharp descent again in its
392 relative abundance. This was attributed to the presence of oxygen in the decanter which
393 is an open tank, where the water remains for almost 2 days. Although the oxygen dissolve
394 concentration in the decanter was always below 0.5 mg/L, it is possible that in the upper
395 levels aerobic bacteria are favoured. At the class level, an increase of *γ-proteobacteria*,

396 which includes denitrifying microorganisms, was observed. The presence ammonia-
397 oxidizing bacteria as *Nitrosomonas* and denitrifiers as *Pseudomonas*, may be beneficial
398 for the subsequent biological treatment. It is necessary to consider that the small quantities
399 of biodegradable organic effluents that are occasionally spilled into the tank may
400 contribute to the differences detected in the microbiology. The variations observed on the
401 relative abundances of bacterial phyla and classes are important to understand the
402 influence of operation ways over the efficiencies of the following biological processes.

403 **ACKNOWLEDGMENTS**

404 The work upon which this paper is based on was co-financed by COGERSA, SAU
405 (Projects FUE-EM-138-15, FUE-139-16), IDEPA (Project IDE/2015/000245), Spanish
406 MINECO (Project CTM2015-63864-R) and FEDER funds from European Union.
407 Technical assistance from the Scientific-Technical Services of the University of Oviedo
408 is gratefully acknowledged.

409 **REFERENCES**

- 410 1. **Cardinali-Rezende, J., Debarry, R.B., Colturato, L.F., Carneiro, E.V.,**
411 **Chartone-Souza, E., and Nascimento, A.M. (2009).** Molecular identification
412 and dynamics of microbial communities in reactor treating organic household
413 waste. *Appl. Microbiol. Biotechnol*, 84 (4), 777-789.
- 414 2. **Venkiteswaran, K., Bocher, B., Maki, J., and Zitomer, D. (2015).** Relating
415 Anaerobic Digestion Microbial Community and Process Function. *Water*
416 *Research*, 8, 37–44. <https://doi.org/10.4137/MBI.S33593>.
- 417 3. **Liu, A.C., Chou, C.Y., Chen, L.L. and Kuo, C.H. (2015).** Bacterial community
418 dynamics in a swine wastewater anaerobic reactor revealed by 16S rDNA
419 sequence analysis. *Journal of Biotechnology*, 194, 124-131.
- 420 4. **Fykse, E.M., Aarskaug, T., Marslien, E.H. and Dybwad, M. (2016).** Microbial
421 community structure in a full-scale anaerobic treatment plant during start-up and
422 first year of operation revealed by high-throughput 16S rRNA gene amplicon
423 sequencing. *Bioresource Technology*, 222, 380-387.
- 424 5. **Zeng, Y., De Guardia, A. and Dabert P. (2016).** Improving composting as a
425 post-treatment of anaerobic digestate. *Bioresource Technology*, 201, 293–303.
- 426 6. **Sancha, M., Laca, A., Laca, A., González, J.M., Mayo, B. and Diaz, M. (2014).**
427 Approaches for Microbiological Characterization of a Landfill Leachate
428 Treatment. *Journal of Residuals Science & Technology*, 11 (2) 1544-8053/14/02
429 039-06.
- 430 7. **Vincent, A.T., Derome, N., Boyle, B., Culley, A.I. and Charette, S.J. (2017).**
431 Next-generation sequencing (NGS) in the microbiological world: How to make
432 the most of your money. *Journal of Microbiological Methods* 138, 60-71.

- 433 8. **Chen, Z., Wang, Y., Li, K., and Zhou, H. (2014).** Effects of increasing organic
434 loading rate on performance and microbial community shift of an up-flow
435 anaerobic sludge blanket reactor treating diluted pharmaceutical wastewater.
436 *Journal of Bioscience and Bioengineering*, 118 (3), 284–288.
437 <https://doi.org/10.1016/j.jbiosc.2014.02.027>
- 438 9. **Zhou, S., Nikolausz, M., Zhang, J., Riya, S., Terada, A., and Hosomi, M.**
439 **(2016).** Variation of the microbial community in thermophilic anaerobic digestion
440 of pig manure mixed with different ratios of rice straw. *Journal of Bioscience and*
441 *Bioengineering*, 122 (3), 334–340. <https://doi.org/10.1016/j.jbiosc.2016.02.012>
- 442 10. **Nelson, M., Morrison, M. and Yu, Z. (2011).** A meta-analysis of the microbial
443 diversity observed in anaerobic digesters. *Bioresource Technology*, 102, 3730–
444 3739.
- 445 11. **Sundberg, C., Al-Soud, W.A., Larsson, M., Alm, E., Yekta, S.S., Svensson,**
446 **B.H., Sorensen, S.J., and Karlsson, A. (2013).** 454 pyrosequencing analyses of
447 bacterial and archaeal richness in 21 full-scale biogas digesters. *FEMS Microbiol.*
448 *Eco.*, 85 (3), 612-626.
- 449 12. **Zamanzadeh, M., Hagen, L.H., Svensson, K. and Linjordet, R. (2016).**
450 Anaerobic digestion of food waste - Effect of recirculation and temperature on
451 performance and microbiology. *Water Research*, 96, 246-254.
- 452 13. **Shu, D., He, Y., Yue, H. and Wang, Q. (2015).** Microbial structures and
453 community functions of anaerobic sludge in six full-scale wastewater treatment
454 plants as revealed by 454 high-throughput pyrosequencing. *Bioresource*
455 *Technology*, 186, 163–172.

- 456 14. **Hu, M., Wang, X., Wen, X. and Xia, Y. (2012).** Microbial community structures
457 in different wastewater treatment plants as revealed by 454-pyrosequencing
458 analysis. *Bioresource Technology*, 117, 72–79.
- 459 15. **Zhang, T., Shao, M. and Ye, L. (2012).** 454 Pyrosequencing reveals bacterial
460 diversity of activated sludge from 14 sewage treatment plants. *The ISME Journal*,
461 6, 1137-1147.
- 462 16. **Abendroth, C., Vilanova, C., Günther, T., Luschig, O. and Porcar, M.**
463 **(2015).** Eubacteria and archaea communities in seven mesophile anaerobic
464 digester plants in Germany. *Biotechnology of Biofuels*, 8 (87). DOI
465 10.1186/s13068-015-0271-6
- 466 17. **Yang, Z., Xu, R., Zheng, Y., Chen, T., Zhao, L. and Li, M. (2016).**
467 Characterization of extracellular polymeric substances and microbial diversity in
468 anaerobic co-digestion reactor treated sewage sludge with fat, oil, grease.
469 *Bioresource Technology*, 212, 164–173.
- 470 18. **Narihiro, T., Nobu, M. K., Kim, N.-K., Kamagata, Y. and Liu, W.T. (2015).**
471 The nexus of syntrophy-associated microbiota in anaerobic digestion revealed by
472 long-term enrichment and community survey. *Environmental Microbiology*, 17,
473 1707–1720. doi: 10.1111/1462-2920.12616
- 474 19. **Gulhane, M., Pandit, P., Khardenavis, A., Singh, D., and Purohit, H. (2017).**
475 Study of microbial community plasticity for anaerobic digestion of vegetable
476 waste in Anaerobic Baffled Reactor. *Renewable Energy*, 101(February), 59–66.
477 <https://doi.org/10.1016/j.renene.2016.08.021>
- 478 20. **Riviere, D., Desvignes, V., Pelletier, E., Chaussonnerie, S., Guermazi, S.,**
479 **Weissenbach, J., Li, T., Camacho, P. and Sghir, A. (2009).** Towards the

- 480 definition of a core of microorganisms involved in anaerobic digestion of sludge.
481 ISME J, 3(6), 700-714.
- 482 21. **Regueiro, L., Veiga, P., Figueroa, M., Alonso-Gutierrez, J., Stams, A.J.M.,**
483 **Lema, J.M. and Carballa, M. (2012).** Relationship between microbial activity
484 and microbial community structure in six full-scale anaerobic digesters.
485 *Microbiological Research*, 167(10), 581-589.
- 486 22. **Maspolim, Y., Zhou, Y., Guo, C., Xiao, K. and Ng, W.J. (2015).** Determination
487 of the archaeal and bacterial communities in two-phase and single-stage anaerobic
488 systems by 454 pyrosequencing. *Journal of Environmental Sciences*, 36, 121-129.
- 489 23. **Dao, H., Kuroda, K., Nakahara, N., Danshita, T., hatamoto, M. and**
490 **Yamaguchi, T. (2016).** 16S rRNA gene-based comprehensive analysis of
491 microbial community compositions in a full-scale leachate treatment system.
492 *Journal of Bioscience and Bioengineering*, 122 (6), 708-715.
- 493 24. **Sun, L., Pope, P. B., Eijssink, V. G. H. and Schnürer, A. (2015).**
494 Characterization of microbial community structure during continuous anaerobic
495 digestion of straw and cow manure. *Microbial Biotechnology*, 8: 815–827.
496 doi:10.1111/1751-7915.12298
- 497 25. **Pervin, H. M., Batstone, D. J., and Bond, P. L. (2013).** Previously unclassified
498 bacteria dominate during thermophilic and mesophilic anaerobic pre-treatment of
499 primary sludge. *Systematic and Applied Microbiology*, 36(4), 281–290.
500 <https://doi.org/10.1016/j.syapm.2013.03.003>
- 501 26. **Ziganshin, A.M., Liebetrau, J., Pröter, J. and Kleinstüber, S. (2013).**
502 Microbial community structure and dynamics during anaerobic digestion of

503 various agricultural waste materials. *Applied Microbiology and Biotechnology*,
504 97(11), 5161-5174.

505 27. **McDonald, J. E., Houghton, J. N. I., Rooks, D. J., Allison, H. E. and**
506 **McCarthy, A. J. (2012).** The microbial ecology of anaerobic cellulose
507 degradation in municipal waste landfill sites: evidence of a role for fibrobacters.
508 *Environmental Microbiology*, 14: 1077–1087. doi: 10.1111/j.1462-
509 2920.2011.02688.x

510 28. **Michalke, K., Wickenheiser, E. B., Mehring, M., and Hirner, A. V. (2000).**
511 Production of Volatile Derivatives of Metal(loid)s by Microflora Involved in
512 Anaerobic Digestion of Sewage Sludge. *Applied and Environmental*
513 *Microbiology*. 66(7), 2791–2796.

514 29. **Guo, J., Peng, Y., Ni, B.-J., Han, X., Fan, L., and Yuan, Z. (2015).** Dissecting
515 microbial community structure and methane-producing pathways of a full-scale
516 anaerobic reactor digesting activated sludge from wastewater treatment by
517 metagenomic sequencing. *Microbial Cell Factories*, 14(1), 33.
518 <https://doi.org/10.1186/s12934-015-0218-4>

519 30. **Jaenicke, S., Ander, C., Bekel, T., Bisdorf, R., Dröge, M., Gartemann, K. H.,**
520 **and Goesmann, A. (2011).** Comparative and joint analysis of two metagenomic
521 datasets from a biogas fermenter obtained by 454-pyrosequencing. *PLoS ONE*,
522 6(1). <https://doi.org/10.1371/journal.pone.0014519>

523 31. **Li, A., Chu, Y., Wang, X., Ren, L., Yu, J., Liu, X., and Li, S. (2013).** A
524 pyrosequencing-based metagenomic study of methane-producing microbial
525 community in solid-state biogas reactor. *Biotechnology for Biofuels*, 6(1), 3.
526 <https://doi.org/10.1186/1754-6834-6-3>

- 527 **32. Di Maria, F., Barratta, M., Bianconi, F., Placidi, P. and Passeri, D. (2017).**
528 Solid anaerobic digestion batch with liquid digestate recirculation and wet
529 anaerobic digestion of organic waste: Comparison of system performances and
530 identification of microbial guilds. *Waste Management*, 59, 172–180.
- 531 **33. Yi, J., Dong, B., Jin, J. and Dai, X. (2014).** Effect of Increasing Total Solids
532 Contents on Anaerobic Digestion of Food Waste under Mesophilic Conditions:
533 Performance and Microbial Characteristics Analysis. *PLoS ONE*, 9, (7)
534 e102548.doi:10.1371/journal.pone.0102548
- 535 **34. Wang, Z., Zhang, X-X., Lu, X., Liu, B., Li, Y., Long, C. and Li, A. (2014).**
536 Abundance and diversity of bacterial nitrifiers and denitrifiers and their functional
537 genes in tannery wastewater treatment plants revealed by high throughput
538 sequencing. *PLOS ONE*, DOI:10.1371/journal.pone.0113603.
- 539 **35. Gao, D., Zhang, T., Tang, C., Wu, W., Wong, C., Lee, Y., Yeh, D. and Criddle,**
540 **C. (2010).** Membrane fouling in an anaerobic membrane bioreactor: Differences
541 in relative abundance of bacterial species in the membrane floculant layer and in
542 suspension. *Journal of Membrane Science*, 364, 331–338.
- 543 **36. De Gannes, V., Eudoxie, G., and Hickey, W. J. (2013).** Prokaryotic successions
544 and diversity in composts as revealed by 454-pyrosequencing. *Bioresource*
545 Technology, 133, 573–580. <https://doi.org/10.1016/j.biortech.2013.01.138>
- 546 **37. Partanen, P., Hultman, J., Paulin, L., Auvinen, P., and Romantschuk, M.**
547 **(2010).** Bacterial diversity at different stages of the composting process. *BMC*
548 Microbiology, 10(1), 94. <https://doi.org/10.1186/1471-2180-10-94>
- 549 **38. Guo, J., Ni, B. J., Han, X., Chen, X., Bond, P., Peng, Y., and Yuan, Z. (2017).**
550 Unraveling microbial structure and diversity of activated sludge in a full-scale

551 simultaneous nitrogen and phosphorus removal plant using metagenomic
552 sequencing. *Enzyme and Microbial Technology*, 102(March), 16–25.
553 <https://doi.org/10.1016/j.enzmictec.2017.03.009>

554

555

FIGURE CAPTIONS

556

557

558

559

Figure 1. Process flow diagram of anaerobic digestion plant. Flow data have been shown in different unit of measurement depending on the operational mode: continuous process (m³/day) and discontinuous process (m³/week). The centrifugation process was carried out for 7 hours per day only 5 days per week.

560

561

562

563

Figure 2. Relative abundance for the phyla detected in the initial sludge (A) and digestate (B) samples (S1 and S2, respectively). In boxes are shown the relative abundance obtained for the classes within *Firmicutes*, *Bacteroidetes* and *Proteobacteria* phyla.

564

565

566

Figure 3. Relative abundance for the phyla detected in the solid phase (A) and clarified (B) samples (S3 and S4, respectively). In boxes are shown the relative abundance obtained for the classes within *Firmicutes*, *Bacteroidetes* and *Proteobacteria* phyla.

567

568

569

Figure 4. Relative abundance for the phyla detected in the decanted product (S5). In boxes are shown the relative abundance obtained for the classes within *Firmicutes*, *Bacteroidetes* and *Proteobacteria* phyla.

570

571

TABLE CAPTIONS

572

Table 1. Characteristics of the samples analysed

573

574

575

Figure 1

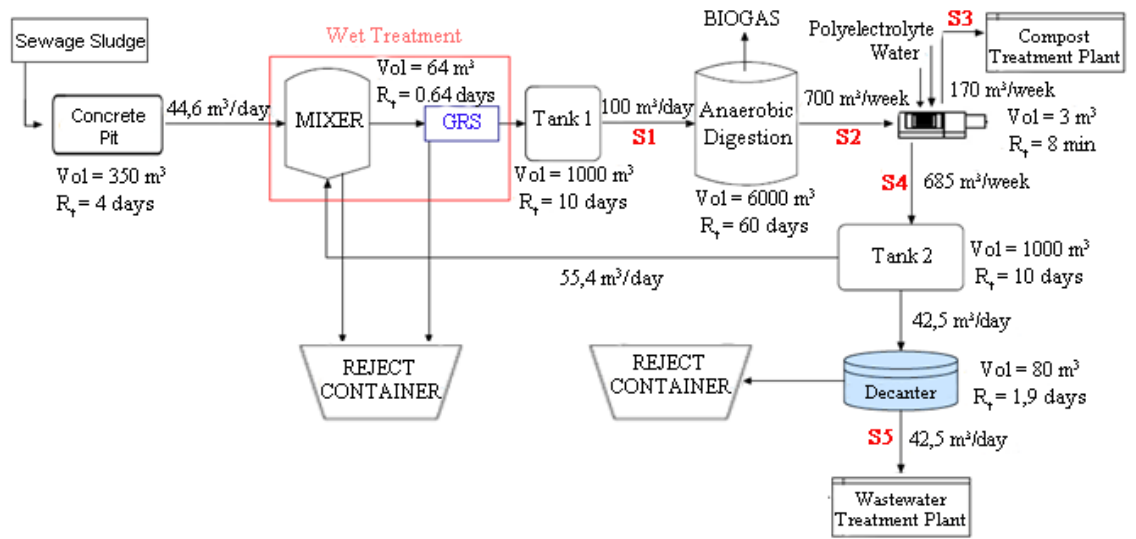
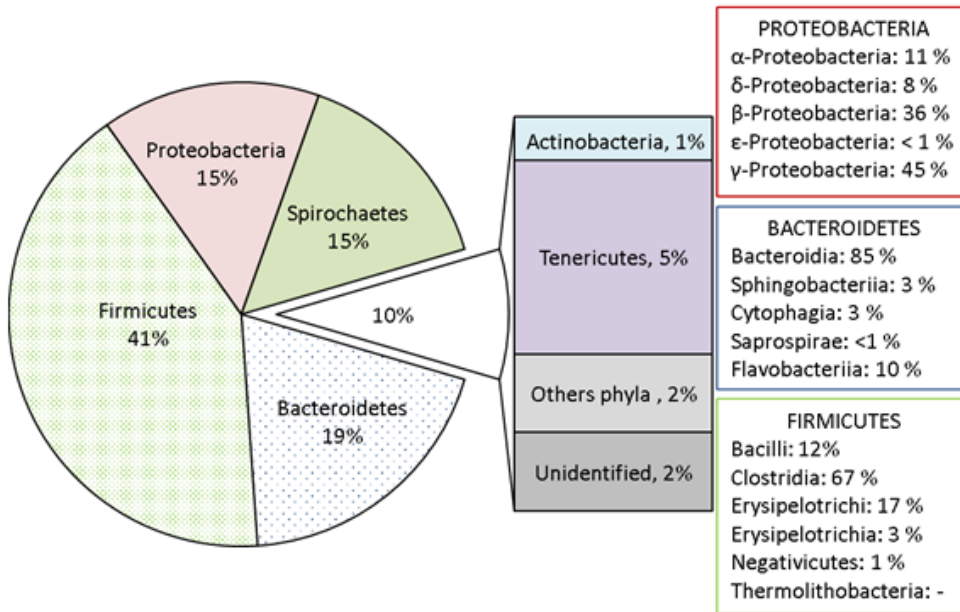

Figure 2

A)



B)

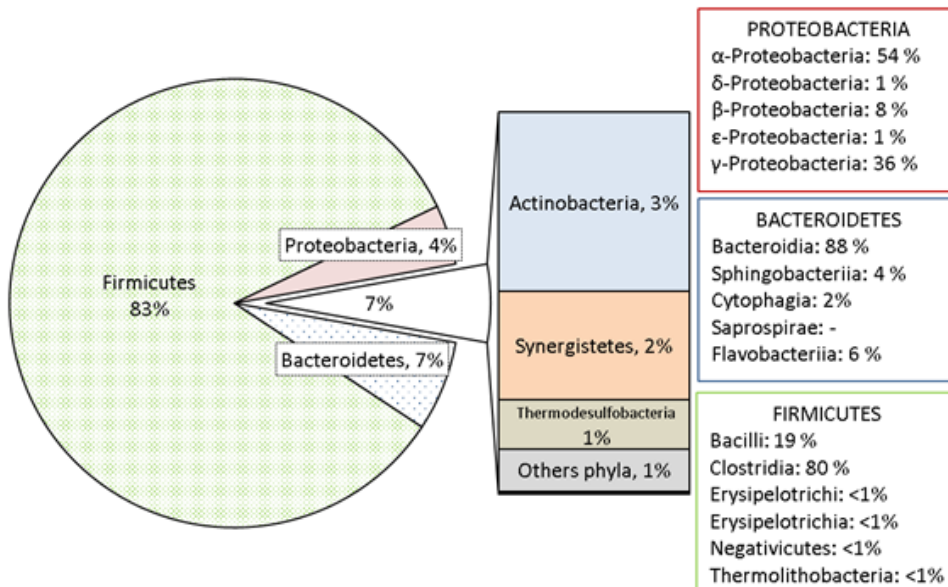
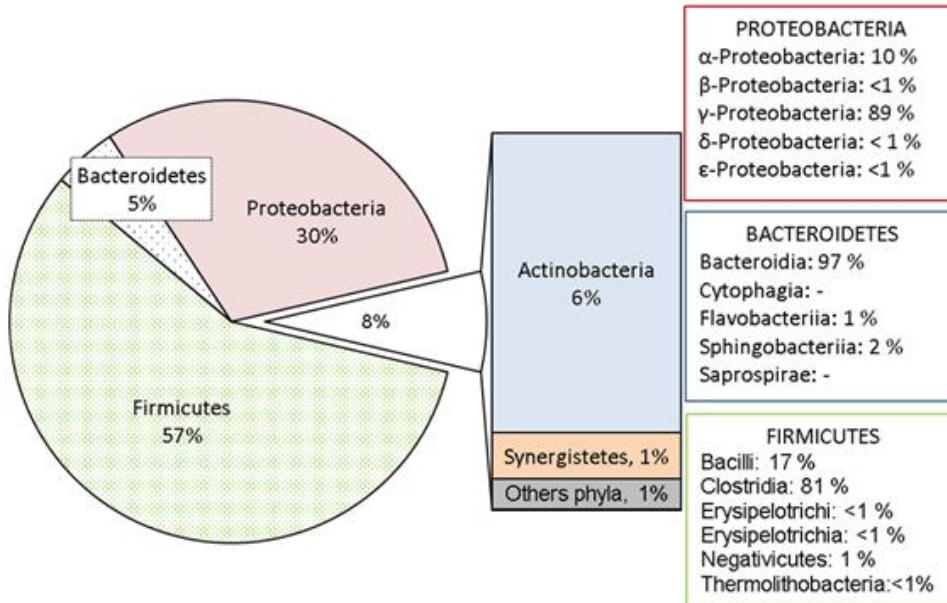

Figure 3

A)



B)

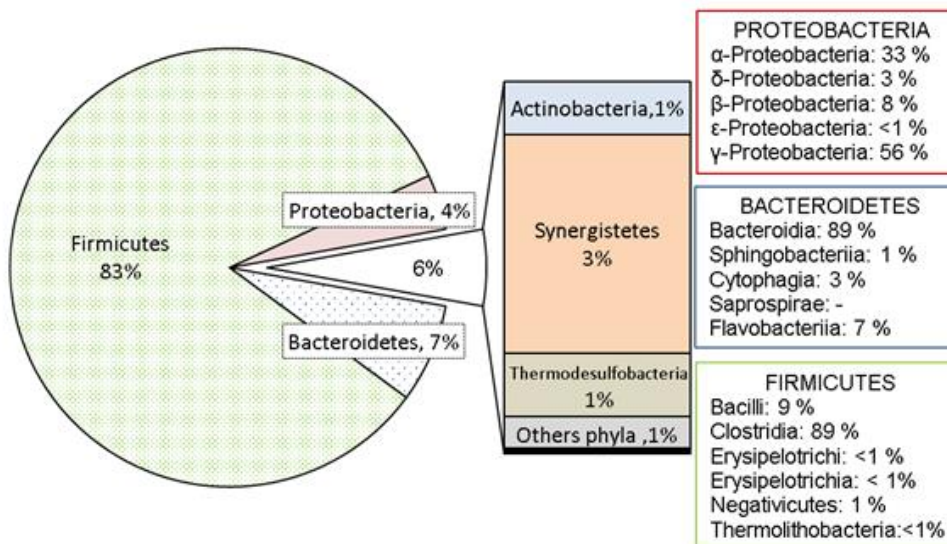

Figure 4

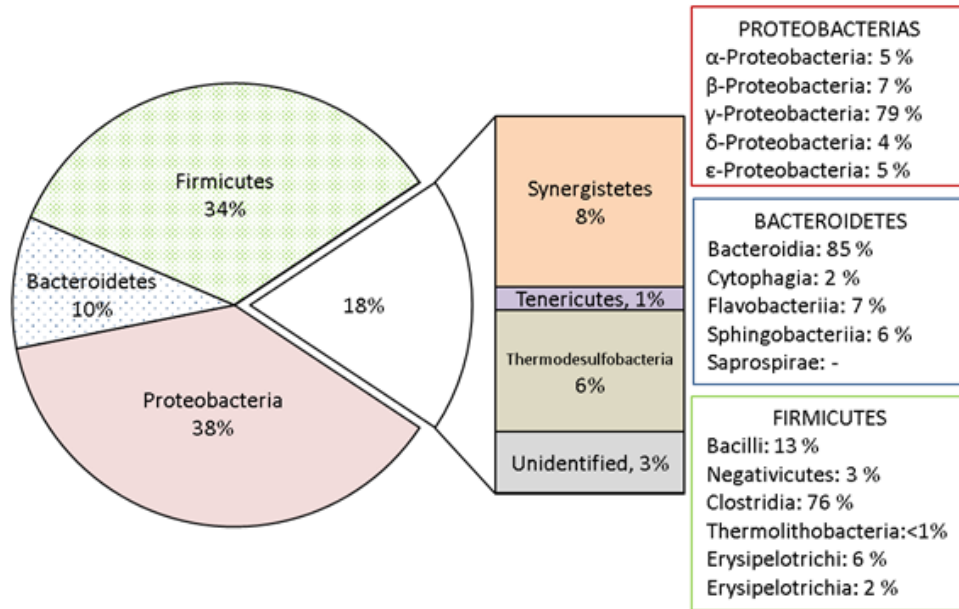

Table 1. Characteristics of the samples analyzed. The average values correspond to four samples taken along 2016.

Samples	Parameters					
	pH (ud.)	COD (mg/L)	NH ₄ (mg/L)	BOD ₅ (mg/L)	TS (mg/L)	Moisture (%)
S1	6.99 ± 0.26	N/A	N/A	N/A	81193 ± 7360	92 ± 0.69
S2	8.13 ± 0.07	56375 ± 1431	5501 ± 421	3750 ± 395	63670 ± 1422	94 ± 0.13
S3	8.21 ± 0.38	67475 ± 13530	17274 ± 1125	N/A	223125 ± 11442	79 ± 1.26
S4	8.39 ± 0.17	10405 ± 4269	4385 ± 428	1525 ± 540	10347 ± 2724	99 ± 0.33
S5	8.42 ± 0.09	10600 ± 4988	3989 ± 177	2735 ± 1572	10198 ± 3544	99 ± 0.30