

# Cooperative Control in a Hybrid DC/AC Microgrid based on Hybrid DC/AC Virtual Generators

Ángel Navarro-Rodríguez  
Dept. of Electrical Engineering  
University of Oviedo, LEMUR Group  
Gijón, Spain  
navarroangel@uniovi.es

Pablo García  
Dept. of Electrical Engineering  
University of Oviedo, LEMUR Group  
Gijón, Spain  
garciafpablo@uniovi.es

Cristian Blanco  
Dept. of Electrical Engineering  
University of Oviedo, LEMUR Group  
Gijón, Spain  
blancocristian@uniovi.es

Ramy Georgious  
Dept. of Electrical Engineering  
University of Oviedo, LEMUR Group  
Gijón, Spain  
georgiousramy@uniovi.es

Jorge García  
Dept. of Electrical Engineering  
University of Oviedo, LEMUR Group  
Gijón, Spain  
garciajorge@uniovi.es

**Abstract**—This paper deals with the dynamic control of the DC bus voltage and the AC voltage magnitude and frequency in a hybrid DC/AC Microgrid (MG). In order to allow a high penetration of renewable energies, provide an increased system reliability during islanding and reduce the dependency on the mains, Energy Storage Systems (ESSs) are included in both the DC and AC grids. The MG is composed by a multiport solid-state-based transformation center, with connexion to the mains and a central battery energy storage system (BESS), and a flexible number of AC Nanogrids (NGs) coupled to a Low Voltage DC bus (LVDC) through DC/AC 3-phase Power Electronic Converters (PECs) operated as grid forming, hereinafter referred as Nanogrid Head Converters (NGHCs). The MG control presents two main characteristics: 1) A DC bus regulation scheme is proposed based on DC virtual generators and P/V DC droop that allows to adapt the participation in the power sharing for DC bus regulation and provides with an automatic transition between *grid connected* and *islanding* modes; 2) In order to provide a cooperative operation between the different AC NGs, allowing the automatic power sharing between them through the DC bus, a DC/AC virtual generator control scheme, based on the theory of Virtual Synchronous Machines (VSM), is proposed for its implementation in the NGHCs, thus coupling the control of the LVDC and the NGs. The theoretical discussion is supported with simulations.

**Index Terms**—DC/AC Hybrid Microgrid, MG control, Virtual Inertia, Virtual Synchronous Generator

## I. INTRODUCTION

The increasing concern about environmental issues, the problematic of renewable energies integration, and the rising popularity of concepts such as local generation and self-

The present work has been partially supported by the predoctoral grants program Severo Ochoa for the formation in research and university teaching of Principado de Asturias PCTI-FICYT under the grant ID BP14-135. This work has been also partially supported by the government of Principality of Asturias, under IDEPA grant 2017 Thyssen SV-PA-17-RIS3-3, by the Research, Technological Development and Innovation Program Oriented to the Society Challenges of the Spanish Ministry of Economy and Competitiveness under grant ENE2016-77919-R and by the European Union through ERFD Structural Funds (FEDER).

consumption have led to an increasing interest on alternatives to the conventional utility grid as Microgrids (MGs), Nanogrids (NGs) and Smart grids. Despite its advantages, the weakness and stability problems associated to a MG, due to its low inertia and the presence of renewable energy systems (RES), have demanded a significant research interest since its apparition. Studies for different types of contingencies have been carried out, pursuing the power quality improvement [1], [2]. Furthermore, with the apparition of hybrid DC/AC MGs, where the Power Electronic Converters (PECs) may share power not only in the AC grid but also in the DC lines, new MG issues appears as the stability, voltage regulation and quality maintenance in both DC and AC grids [3]–[5].

Several methodologies and control topologies for distribution network (DN) and MGs have been presented in the literature to ensure the voltage control and power flow, as the central controller, the master-slave, the Q/V and P/f droops, the virtual impedance, and hybrid approaches [6]–[9]. In addition, during the recent years a relatively novel approach for MGs distributed control is becoming popular, consisting on the emulation of Synchronous Generators through PECs leading to the well-known terms of Virtual Synchronous Generators (VSG), Virtual Synchronous Machines (VSM), Synchronverters and Virtual Inertia (VI). The integration of VSGs in the MGs allows to imitate the behavior of conventional grids dominated by Synchronous Generators (SG), providing the MG with an additional inertia, softening the frequency and magnitude rate of change during active power transients. Moreover, VSGs avoid the use of frequency or phase detectors for synchronization and allows the integration of conventional SGs in the MGs together with DGs, RESs, ESS and loads interfaced by PECs. Additionally, the stability and dynamic active power balance in the grid can be improved by adding a VI using ESSs, increasing the grid inertia and damping, adding flexibility to the system [10]–[14]. Besides, the VSG scheme can also be combined with Q/V and P/f droops in order to

manage the steady state power sharing in the MG.

Regarding the dynamic power sharing between hybrid DC/AC MGs when 3-phase inverters operated as grid forming are used for the coupling between the Low Voltage DC line (LVDC) and the AC grid, few discussion is found in the literature. Some studies have been proposed based on cascaded converters stability [15], and power balancing between AC and DC using a  $V_g/V_{dc}$  droop [16]. However, these methods have been proposed for AC/DC/AC grid tied converters and they can not be directly applied to the AC/DC voltage control of a hybrid MG. In [17], an adaptive power sharing scheme for hybrid DC/AC is proposed for a MG where fixed frequency slack voltage-controlled converters are used to couple the AC grids to a LVDC, based on a central controller for the LVDC regulation and distributed compensation in the AC grids. Another approach related to the proposal in this paper is found in [18], where a VSM is proposed as an interface between a DC grid and a non-islanded AC grid. However, although the methods can be useful for the present study, the model is demonstrated only for a single phase grid and just consider the connection to one AC grid that operates as a grid feeding converter.

Thus, this paper deals with the dynamic control of the LVDC bus voltage and the AC voltage magnitude and frequency in a hybrid DC/AC MG with ESSs. The MG is composed by a multiport solid-state-based transformation center, with connection to the mains, a central Battery Energy Storage System (BESS), and multiple AC NGs coupled to a LVDC through DC/AC 3-phase PECs. They are referred as Nanogrid Head Converters (NGHCs), and play the role of grid forming converters in their corresponding NGs. The paper proposed two main strategies: 1) A DC voltage regulation scheme based on DC virtual generators and P/V DC droop that allows to adapt the participation of the mains and BESS in the transient and stationary power sharing for DC bus regulation, providing with an automatic transition between *grid connected* and *islanding* modes. 2) in order to provide a cooperative operation of the different AC NGs and the LVDC bus, allowing the automatic power sharing between them, a DC/AC virtual generator control scheme, based on the theory of Virtual Synchronous Machines (VSMs), but here extended to include a DC machine mechanically coupled using the virtual shaft concept, is proposed for its implementation in the NGHCs, coupling the control of the LVDC and the NGs. The proposal pursues a reduced dependency on the mains and the reduction of stress in the central BESS.

It is worth to point out that the transition between *grid connected* and *islanding* modes is automatic and no islanding detection is needed to maintain the DC bus under regulation.

The paper is organized as follows. Section II introduces the hybrid DC/AC Microgrid topology under study and the set-point control regarding DC bus and AC NGs regulation. Section III describes the proposed Hybrid DC/AC virtual generator. Section IV explains the basics of the proposed cooperative DC/AC MG control. Section V describes the operation of DERs for grid frequency support. Section VI

presents the simulation results. Finally, section VII states the conclusions.

## II. HYBRID MG DESCRIPTION AND PROPOSED SET-POINT CONTROL

The hybrid MG under study, shown in Fig. 1, is composed by a MG transformation center (MGTC) and multiple 3-phase 4-wires AC NGs based on VSG control topology. The MGTC consists of a BESS and a MG head converter (MGHC) coupled to the mains, interconnected by a common DC bus (LVDC) to the NG Head Converters (NGHCs) that interface the LVDC with the AC NGs. The BESS and MGHC are interfaced with the LVDC by a three-port solid-state transformer (SST). It is necessary to point out that, in the present study, the main aim of the SST is to provide galvanic isolation between the mains, BESS and LVDC bus and it operates at a high bandwidth compared to the rest of elements in the MG. Thus, its dynamics are neglected and, from the point of view of the MG control it is assumed to behave as a unitary gain.

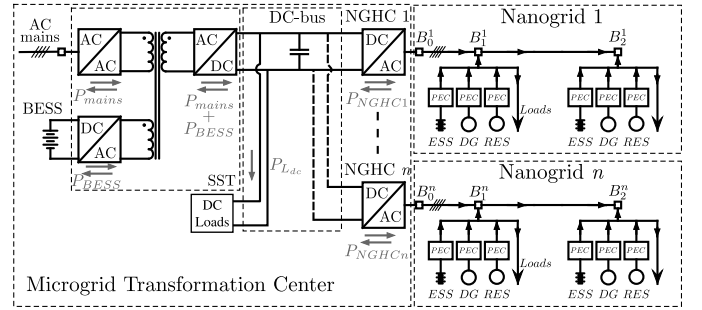

Fig. 1: Topology of the Hybrid DC/AC Microgrid under study.

As a starting point, the MG control is designed as follows: 1) The NGHC acts as Grid Forming converters with a dynamic control based on VSG scheme, regulating both the AC voltage magnitude and frequency, assuming they are the highest rated power source in each NG. As starting scenario, the MGs loads are located at the AC NGs and the LVDC bus. Under this configuration, the load as seen by the LVDC bus is drawn by the NGHCs and the DC loads. 2) Additionally, different distributed energy resources (DERs) such as Distributed Generation (DGs) and ESSs can be installed within the AC NGs. Those DERs can operate in a stiff PQ basis, P/f Q/V droop mode or as VSG or VI providing additional inertia to the grid. The power commands for the DGs and ESSs can be determined by the droop control, by a central controller performing a high level optimal power flow, or by the Maximum Power Point Tracking (MPPT) in the case of RESs. 3) The LVDC bus voltage is regulated by the MGHC (mains) and the BESS under a proposed control scheme based on DC virtual generators and P/V DC droop. During *islanding*, the DC voltage regulation relies only on the BESS.

In conventional grids, the power mismatches are absorbed by the high inertia of generators. However, in MGs, which are usually dominated by PECs or low inertia SGs, the grid inertia must be provided by the energy storage elements present in

the grid, including the DC link capacitors, and the inertia of generators in PEC based DERs. Nonetheless, the use of PECs as interface with the grid involves a decoupling from the generation system and energy storage devices, being the use of the inertial elements dependent on the PEC control. Applying the model of VSGs to the PEC control in DGs and DESS allows to increase the overall MG inertia and attach the active power to the grid frequency. Moreover, in the proposed MG scheme any DER can provide additional VI as an ancillary service taking advantage of its inherent inertia, and ESSs can be integrated in the NGs to improve the dynamic response by frequency compensation, adding flexibility to the grid [10]. As an initial set-point in the proposed MG, the DGs and DESS in the NG might contribute to the grid regulation or might operate with constant PQ commands, while the NGHCs, operated as a VSG, will regulate the voltage and frequency, being the highest inertial source in the NG, and thus absorbing the main part of the power mismatches in its corresponding NG. Under this scenario, the NGHCs are decoupled from the LVDC bus regulation, and the power mismatches supported by the NGHCs are entirely provided by the mains and the central BESS, being the NGs agnostic about each other. This creates an important dependency in the mains and a high stress on the central BESS.

Fig. 2 shows the simplified power scheme of one of the NGHCs including the different elements participating on the power sharing, where  $k$  is the NG identifier and  $n$  is the total number of AC NGs. Considering the given power topology for the NGHCs, it is worth noting that under a control based on grid forming, the NGHC cannot participate directly in the LVDC regulation.

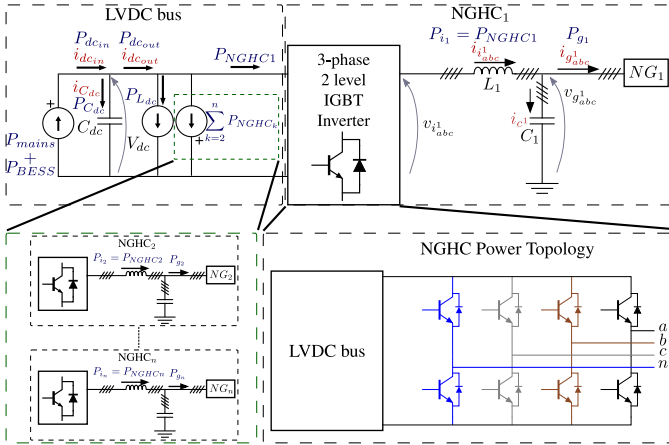

Fig. 2: Power sharing within the Hybrid DC/AC MG: NGHC topology and simplified equivalent power scheme for one of the NGHCs.

In this paper, some assumptions are established for simplification. 1) The DC bus is simplified to a capacitor. 2) The inner current control loop of the PECs interfacing the mains and the central BESS will be approximated by a low pass filter (LPF). 3) Although the application is implemented with 4

wires NGHCs (3ph+N), a balanced system will be considered, being the effect of unbalances out of the scope of this paper.

### A. Grid forming VSG-based NGHC control

The set-point VSG control topology proposed for the NGHCs is shown in 3. It is implemented in the dq synchronous reference frame and consists of: 1) a virtual stator impedance model (resistance  $R_s^k$  and inductance  $L_s^k$ ) that emulates the VSG stator and generates the current reference  $i_{i_{dq}^k}^*$ ; 2) a vector current controller; 3) an emulation of an Automatic Voltage Regulator (AVR) to regulate the NG voltage in steady state by generating a virtual voltage,  $E_d^k$ ; 4) a governor model that regulates the rotor speed,  $\omega_e^k$ , i.e., the frequency; and 5) the rotor model emulating a VI with the VSG swing function (damping  $b_r^k$ , inertia  $J_r^k$ ) that determines the grid frequency and the synchronization angle  $\theta_e^k$ .

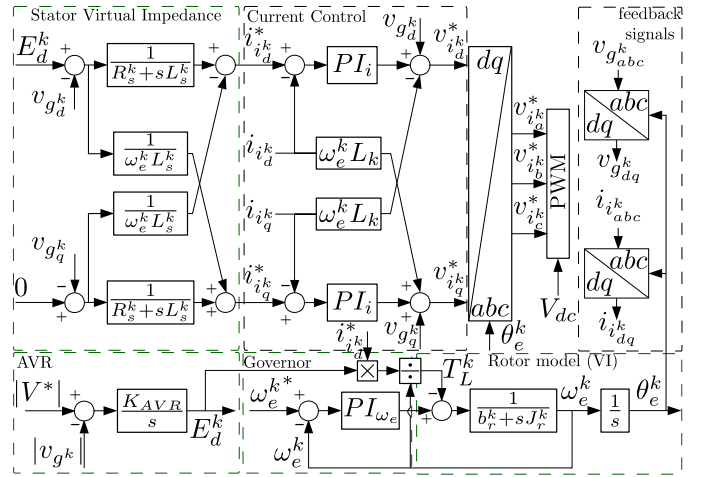

Fig. 3: Set-point grid forming VSG control block diagram proposed for the implementation in the NGHCs.  $k$  is the NG identifier.

### B. DC voltage regulation: The DC Virtual Generator

The DC link can be modeled as (1), where  $C_{dc}$  is the LVDC capacitor,  $P_{dcin}$  is the power shared by the SST (BESS & mains) (2) and  $P_{dcout}$  is the power drawn by the NGHCs and the DC loads. The power related to the NGHCs is defined by (3), assuming  $v_{gq} = 0$ . Thus, the NGHCs are seen as CPLs by the DC link. The power flowing into the capacitor is defined as  $P_{C_{dc}} = P_{dcin} - P_{dcout}$ .

$$\frac{dV_{dc}(t)}{dt} = \frac{1}{C_{dc}V_{dc}(t)} \left( P_{dcin}(t) - \underbrace{\left( \sum_{k=1}^n P_{NGHC_k}(t) + P_{L_{dc}}(t) \right)}_{P_{dcout}} \right) \quad (1)$$

$$P_{dcin}(t) = P_{mains}(t) + P_{BESS}(t) = V_{dc}(t)(I_{mains}(t) + I_{BESS}(t)) \quad (2)$$

$$\sum_{k=1}^n P_{NGHC_k(t)} = \sum_{k=1}^n \frac{3}{2} \left( v_{gd(t)}^k i_{id(t)}^k \right) \quad (3)$$

The proposed LVDC regulation scheme consists in the dynamic power sharing between the mains and the BESS through DC virtual generators (DCVGs) and P/V DC droops. This control topology presents two main characteristics: 1) The DC virtual generators enable to modify the DC bus inertia and to define the transient power sharing between the mains and BESS. For instance, in some cases it will be more desirable to provide the high frequency variations with the mains, reducing the stress in the BESS, while in others, it could be the opposite. 2) The P/V droop permits to establish a decentralized sharing mechanism during steady state.

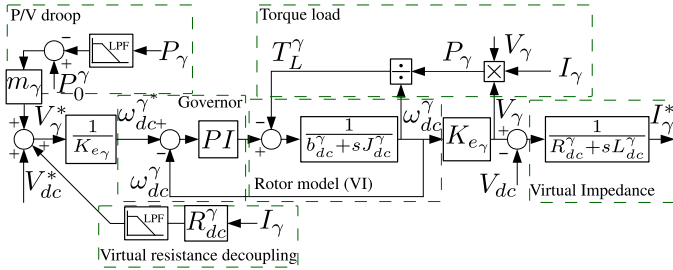

Fig. 4: DC virtual generator (DCVG) proposed for the distributed regulation of DC voltage and the power sharing between the mains and the central BESS. The identifier  $\gamma$  can be substituted by mains or BESS.

The proposed DCVG control scheme and its integration in the MG topology are shown in Fig. 4 and Fig. 5 respectively, valid for both the MGHC (mains) and the BESS.  $\gamma$  is a identifier that can represent mains or BESS. The scheme can be divided in 8 blocks:

- 1) *P/V droop*: where  $m_\gamma$  is the droop gain,  $P_0^\gamma$  is the offset commanded power and  $P_\gamma$  is the measured output power.
- 2) *Reference calculation*: the DCVG output voltage reference is calculated based on the P/V droop output, the LVDC bus nominal voltage  $V_{dc}$  and a virtual resistance decoupling. After the calculation of  $V_\gamma^*$ , a back electromotive force (bemf) constant ( $K_{e_\gamma}$ ) is applied to convert voltage to frequency ( $\omega_{dc}^\gamma$ ).
- 3) *Governor*: it consist of a feedback PI regulator which aim is to track the ( $\omega_{dc}^\gamma$ ) reference.
- 4) *Rotor model*: is the virtual plant that provides the virtual inertia ( $J_{dc}^\gamma$ ) and friction ( $b_{dc}^\gamma$ ) to the system.
- 5) *Torque load*: is the disturbance of the virtual system and is obtained from the instantaneous power shared by the mains or BESS.
- 6) *Frequency to voltage conversion*: the virtual generator voltage is obtained from the virtual frequency ( $\omega_{dc}^\gamma$ ), using the constant  $K_{e_\gamma}$ .
- 7) *Virtual Impedance*: a virtual impedance is used to determined the current reference which feed the inner control

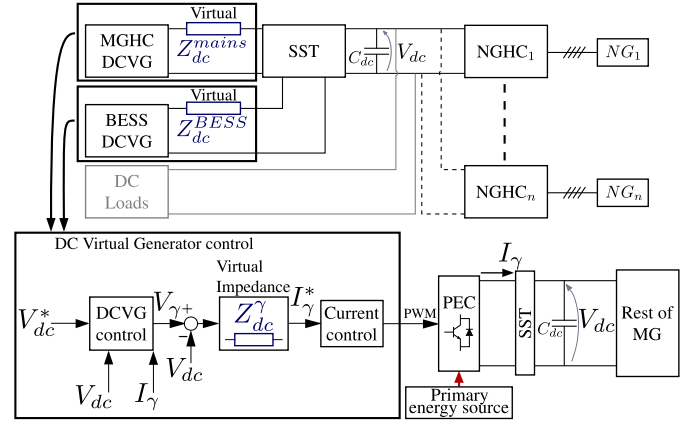

Fig. 5: Integration of the DC virtual generator in the DC bus. The identifier  $\gamma$  can be substituted by mains or BESS.

loops of the MGHC and BESS. The impedance consists of a resistance and an inductance ( $Z_{dc}^\gamma(s) = R_{dc}^\gamma + sL_{dc}^\gamma$ ).

- 8) *Virtual resistance decoupling*: suppress the voltage deviation during steady state due to the virtual impedance.

In order to demonstrate the operation of the proposed sharing scheme in DC, the power sharing performance for different values of inertia in the MGHC and the BESS is shown in Fig. 6. The figure shows the power shared by the mains ( $P_{mains}$ ), the BESS ( $P_{BESS}$ ), the load disturbance ( $P_{L_{dc}}$ ) and the power supplied by the LVDC bus capacitor ( $P_{C_{dc}}$ ). Three cases are compared: 1) the mains have a larger inertia, resulting in a higher contribution than the BESS during the transient; 2) both inertias are the same, contributing the mains and BESS equally to the initial transient; 3) the BESS presents higher inertia, supporting the transient power mismatch. In all the cases, the DC bus capacitor supplies the high bandwidth power mismatches. The stationary power sharing remains unchanged for the 3 cases and depends on the P/V DC droop ( $m_{mains} = 0.02$ ,  $m_{BESS} = 0.002$ ).

In this paper, the first scenario will be assumed, presenting the MGHC (mains) a higher inertia and power sharing contribution while the BESS remains as a MG back-up in case of contingencies in the mains, especially for *islanding* condition. The BESS inertia is kept low in order to reduce the stress on the battery and increase its life time. Fig. 7 illustrates the system behavior in the DC side for the set-point control under *grid connected* and *islanding* operation. As shown, once the mains is disconnected at  $t=3.65s$ , the battery has to fully support the DC link regulation, however, due to its low inertia, the DC voltage drop during transients becomes larger. At  $t=4.1s$  the mains is reconnected. It is worth to point out that the transition between *grid connected* and *islanding* modes is automatic and no islanding detection is needed to maintain the DC bus under regulation. The stationary voltage deviation with respect to the nominal DC voltage ( $V_{dc}^*$ ) is due to the P/V DC droop.

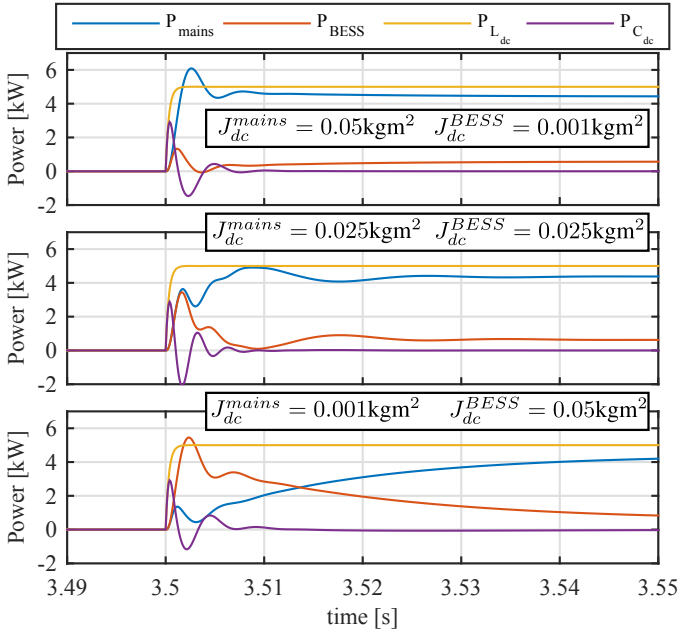

Fig. 6: Power sharing in the DC voltage regulation based on DC virtual generators. Comparison of the performance for different values of inertia in the MGHC (mains) and the BESS under a DC constant power load step disturbance in the DC bus.

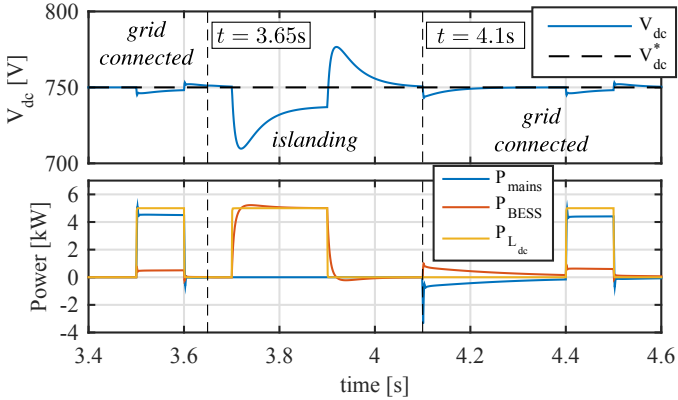

Fig. 7: LVDC control performance and power sharing during grid connected and islanding operation. The MG enters in islanding mode at  $t=3.65s$  and returns to grid connected at  $t=4.1s$

### III. VIRTUAL DC/AC GENERATOR SCHEME

The proposed Hybrid DC/AC virtual generator for the implementation of the NGHCs control is shown in Fig. 8. The proposed control is based on the model of a virtual DC generator mechanically coupled to a VSG through the rotor shafts. While the AC stator model, the current regulator and the AVR remains the same as in Fig. 3, the control related to the frequency regulation is modified to be dependent on the LVDC voltage. The governor is replaced by the model of a DC Virtual Machine (DCVM) and it consist of: 1) a DC

stator model ( $R_{dc}^k$  and  $L_{dc}^k$ ) that emulates a DC virtual stator impedance and establish the electrical torque applied to the DC machine depending on the LVDC voltage  $V_{dc}$  and a back electromotive force (bemf)  $E_{dc}^k$ ; 2) an AC/DC virtual rotor that provides the VI to the NGHC, determining the grid frequency; and 3) a frequency regulator based on the variation of the rotor flux  $\varphi$  to modify the relation between the rotational speed  $\omega_e^k$  and the bemf  $E_{dc}^k$ . The regulator  $R_{\omega_e^k}$  can be implemented as a slow PI or as an integrator, as the main function of this block is regulating the steady state frequency. In order to improve the response during start up, the inverse of the nominal bemf constant  $K_e^{-1}$  is applied as a feed-forward.

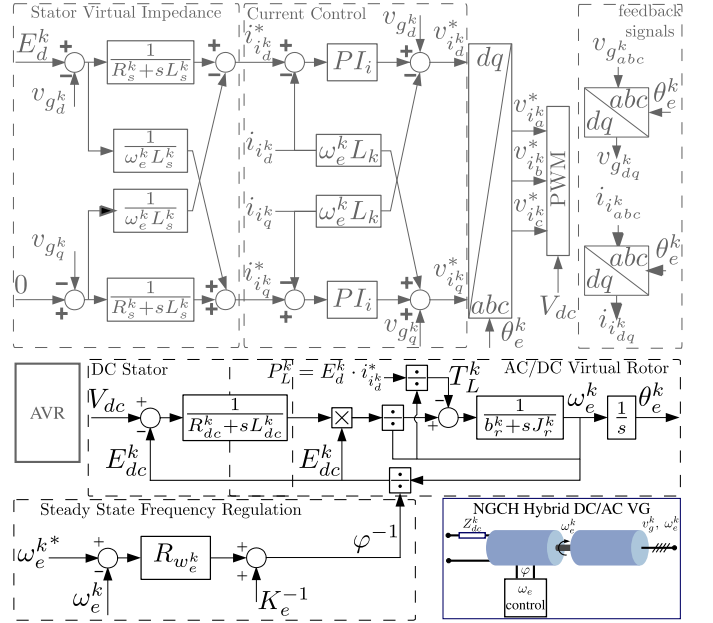

Fig. 8: Block diagram of the proposed Hybrid DC/AC virtual generator for enabling the cooperative power sharing between NGs through the LVDC.

The basic principle of operation consists on the following: in case the LVDC voltage varies, the frequency in the NGs will change, dynamically and proportionally, with the dynamics of the defined DC/AC virtual generator. The frequency regulator will allow to decouple the NGHC frequency  $\omega_e^k$  from the  $V_{dc}$  during steady state, thus the frequency can return to its nominal value even if the  $V_{dc}$  deviates from the nominal DC bus voltage.

### IV. COOPERATIVE DC/AC HYBRID MG CONTROL

The cooperative control consists in the integration of the Hybrid DC/AC virtual generator within the defined MG. Including the LVDC regulation based on DCVGs, the conceptual representation of the system based on virtual generators is shown in Fig. 9.

Unlike in the initial set-point presented in section II, once the proposed Hybrid DC/AC virtual generator is implemented in the NGHCs, the LVDC bus voltage behavior is coupled

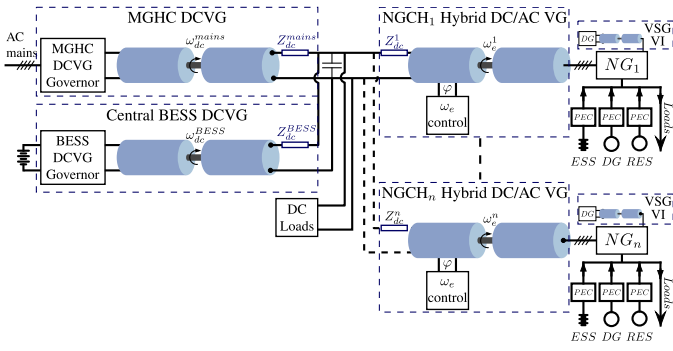

Fig. 9: MG representation with the proposed structure based on virtual generators.

to the grid frequency in the NGs. Thus, the NGHCs become sensitive to disturbances in the LVDC, and therefore, to the active power changes in other NGs, participating automatically in the LVDC regulation. This reduces the dependence on the mains, and alleviates the participation of the central BESS. During transients, the stiffness of the NGHCs will be softened and the inertial elements in the NGs (DERs operated as VSG or VI) will react to the frequency variation, injecting or absorbing active power. On the other hand, in case the BESS or the mains are not able to provide the required power during steady state, the system, including the LVDC bus, will be supported by those DERs in the NGs able to provide power during steady state. In order to allow this behavior, and increase the participation in the Hybrid DC/AC NG power sharing, either in transients or steady state, there should be DERs in the NGs that reacts to changes in frequency. This can be achieved by using VSG combined with droop controls or by using dedicated frequency compensation devices based on VI.

#### V. DGs AND ESS PARTICIPATION IN THE NGs

As mentioned before, apart from PQ mode and MPPT mode, some of the DERs within the NGs (DGs and ESS) can be operated as VI-based frequency compensators or VSGs in order to participate in the voltage magnitude and frequency regulation. This allows to provide additional inertia to the grid, and, if combined with P/f Q/V droop, decentralized cooperation during steady state. Two options are considered for voltage and frequency support in the NGs.

One of the most extended solutions for frequency compensation is to use ESSs operated as a virtual inertia. The controller in dq frame is defined by the swing equation (4), where  $i_{vi,d}^*$  is the current reference of the frequency compensator,  $K_{vi}$  the damping coefficient,  $J_{vi}$  the VI gain, and  $v_{pcc,d}$  is the voltage at the point of connection. The frequency  $\widehat{\omega}_e$  is the frequency estimated at the point of common coupling.

$$i_{vi,d}^*(t) = \left( \underbrace{K_{vi} \cdot (w_e^*(t) - \widehat{w}_e(t))}_{\text{Damping factor}} - \underbrace{J_{vi} \cdot \frac{d\widehat{w}_e(t)}{dt}}_{\text{Virtual Inertia}} \right) \frac{\widehat{w}_e(t)}{v_{pcc,d}(t)} \quad (4)$$

TABLE I: System Parameters

AC NGs and NGHCs Parameters	Values
AC Nominal Voltage ( $v_g^k, \omega_e^k$ )	230 V <sub>AC,rms</sub> / 50Hz
NGHCs Filter ( $L_k, C_k$ )	1mH / 80μF
NGHCs Virtual Impedance ( $L_s^k, R_s^k$ )	0.1mH / 2Ω
NGHCs AVR integral gain ( $K_{AVR}^k$ )	5
NGHCs Virtual Inertia ( $J_r^k, b_r^k$ )(case 1)	0.1kgm <sup>2</sup> / 1Nm/s
NGHCs Virtual Inertia ( $J_r^k, b_r^k$ )(case 2)	3kgm <sup>2</sup> / 0.01Nm/s
NGHCs Governor BW (case 1)	50Hz
NGHCs DC Virtual Impedance ( $L_{dc}^k, R_{dc}^k$ )	0mH / 1Ω
NGHCs freq reg $R_{\omega_e^k}$ ( $K_{p\omega_e^k}, K_{i\omega_e^k}$ )	0.01 / 0.01
NG <sub>2</sub> Frequency compensator ( $K_{vi}, J_{vi}$ )	6 / 1kgm <sup>2</sup>
LVDC Parameters	Values
DC Nominal Voltage ( $V_{dc}^*$ )	750 V
Current control BW (mains & BESS)	500Hz
DC bus Capacitor ( $C_{dc}$ )	750μF
$K_{e_{mains}}$ and $K_{e_{BESS}}$	2.38 V·s/rad
DCVGs Virtual impedance $L_{dc}/R_{dc}^\gamma$	0mH / 1Ω
mains droop gain $m_{mains}$	$2.5 \times 10^{-5}$
BESS droop gain $m_{BESS}$	$2.08 \times 10^{-4}$
mains Virtual Inertia ( $J_{dc}^{mains}, b_{dc}^{mains}$ )	0.005kgm <sup>2</sup> / 0.01Nm/s
BESS Virtual Inertia ( $J_{dc}^{BESS}, b_{dc}^{BESS}$ )	0.001kgm <sup>2</sup> / 0.015Nm/s
mains and BESS Governor BW	50Hz

#### VI. SIMULATION RESULTS

The proposed system has been validated through simulations in MATLAB/Simulink<sup>®</sup>. The parameters are summarized in Table I.

##### A. MG performance under the proposed control scheme

Two cases are simulated to evaluate the performance of the proposed cooperative control: 1) The first case consist in the simulation of the base set-point case describe in section II. The LVDC bus is regulated by the MGHC and BESS operated as DCVGs with a P/V DC droop as described in section II-B. The MGHC (mains) provides the majority of the inertia and steady state power sharing while the central BESS is mainly conceived as a back up for contingencies like *islanding*, presenting low inertia and reduced participation in the power sharing under normal conditions. The NGHCs are controlled as grid forming according to the VSG topology in Fig. 3, presenting a stiff governor response and a high VI. 2) In the second case, the control in the NGHCs is modified, introducing the Hybrid DC/AC virtual generator proposed in section III, shown in Fig. 8. The LVDC bus regulation remains the same as in the first case.

In both cases, the parameters in common are the same and similar conditions are established: 1) two NGs are connected to the LVDC line; 2) In the  $NG_1$  just active loads are connected to the grid. 3) a DC load ( $P_{Ldc}$ ) is directly connected to the LVDC bus. 4) In the  $NG_2$  not only active loads, but also a DER operated as a frequency compensator is present in the NG. The frequency compensator, operated based on the VI controller defined by (4), could be implemented by any DG or a local ESS with high dynamics; 5) two modes of operation are considered *grid connected* and *islanding*. Under *grid connected* the power to control the LVDC is shared by the mains and the central BESS. During *islanding*, the LVDC control relies only in the BESS. As the BESS is configure

with a reduced inertia, the DC voltage profile will be affected during transients. Moreover, due to the power limitations of the central BESS, the system stability can be compromised if an overrated operation is reached.

The simulations evaluate the 2 modes of operation under multiple active power steps in the NGs and LVDC bus. The results, comparing the two studied cases are shown in Fig. 10. It shows the DC voltage, the AC voltage in both NGs, grid frequency in each NG, the power delivered by the mains, central BESS and frequency compensator, and the load in each NG and DC bus. The figure is described as follows:

- From  $t = 0s$  to  $t = 1.2s$  the MG operates in *grid connected* mode. During this mode the  $V_{dc}$  response presents a high stiffness in both cases. For the case 1, the grid frequency is only affected by power changes in the corresponding NG, thus, the NGs does not react to the DC load. Conversely, in the second case, the frequency in both NGs is sensitive to changes in any NG and the DC bus, being slightly disturbed by the DC load connection and disconnection.
- From  $t = 1.2s$  to  $t = 3s$  the mains are disconnected and the MG changes to *islanding* mode. In case 1, the operation in the NGs is similar than in *grid connected*, however, the  $V_{dc}$  profile is notably worsen, presenting the case 2 a better LVDC profile thanks to the proposed cooperative control. For case 2, the coupling between NGs and DC bus becomes evident, in both voltage and frequency signals. Thus, the frequency compensator not only helps with the frequency regulation in  $NG_2$ , but also collaborate with the LVDC regulation and the frequency regulation in  $NG_1$  indirectly, reacting to the  $NG_1$  load and the DC load. It is clearly seen how the battery stress is reduced compared with case 1. In both cases a better frequency response is observed in the  $NG_2$ , due to the presence of the frequency compensator. Despite the  $V_{dc}$  steady state deviation due to P/V DC droop, it is worth noting how in the case 2 the frequency steady state error in both NGs is zero thanks to the frequency regulation block.
- At  $t = 3s$  the total load in the MG exceeds the central BESS maximum power. In case 1, as the NGHCs are decoupled from the  $V_{dc}$  regulation, the whole system leads to instability and collapses although there is available power in the frequency compensator of  $NG_2$ . On the other, the proposed control allows to maintain the system operation automatically, in trade of an steady state error in the  $V_{dc}$  and the NGs' frequencies, being the active power mismatch sustained by the frequency compensator of  $NG_2$ .

### B. P/V DC droop performance

In order to evaluate the functioning of the P/V DC droop and its effects on the system performance, an additional simulation, shown in Fig. 11, has been carried out for illustrating in detail its operation under a DC load step and a sudden change in the mains and BESS droop gains during *grid connected*

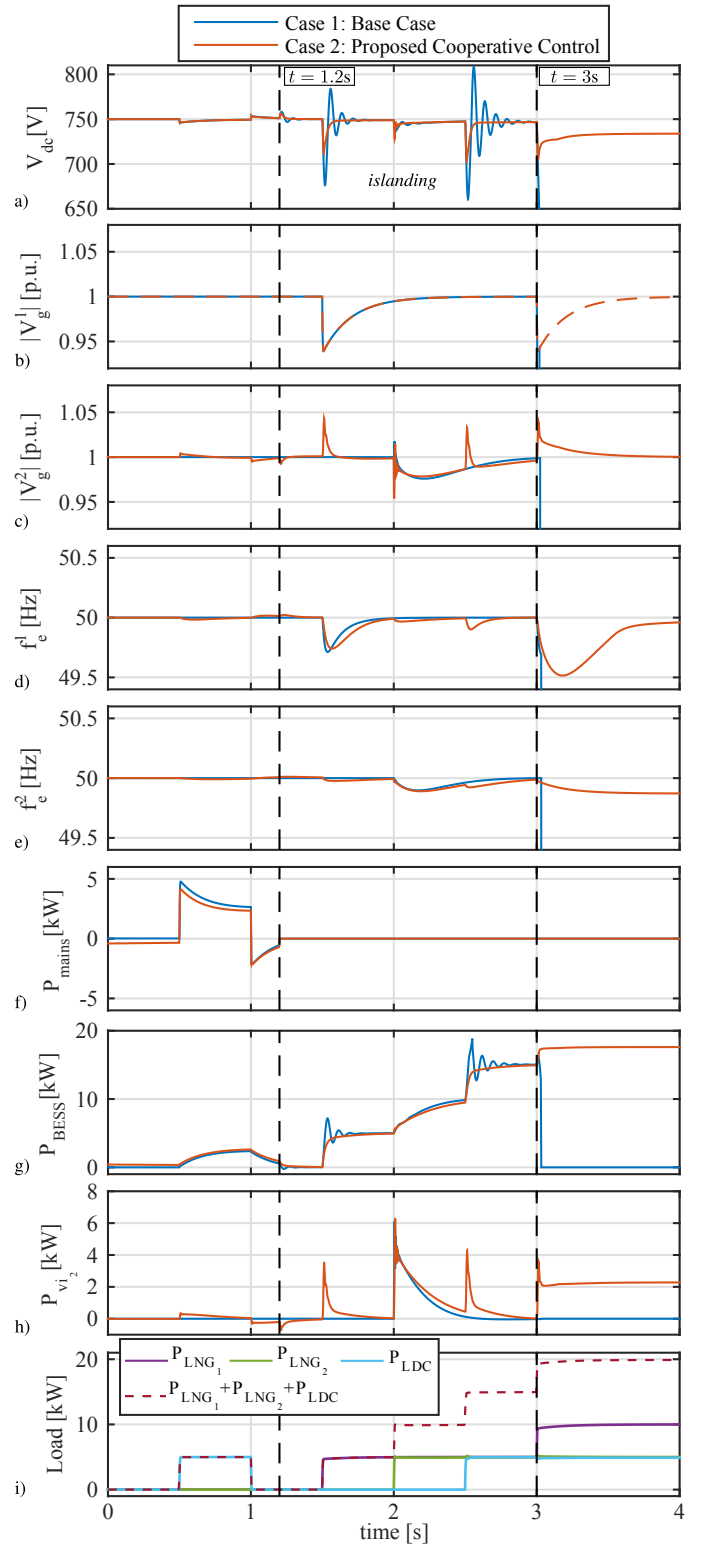

Fig. 10: Simulation results: comparison between the base case and the proposed cooperative hybrid MG control. a) LVDC bus voltage; b) and c) NGs voltage magnitude; d) and e) NGs frequency; f),g) and h) power shared by the mains, BESS and frequency compensator; i) NGs AC loads and DC load.

mode. At  $t=1$ s a DC load is connected. As a consequence the LVDC voltage drops due to the P/V droop and the mains and BESS virtual generator voltages are modified to provide a determined power sharing. The NGs frequencies are also affected, returning to its nominal value after the transient. At  $t=4$ s, the droop gains are changed, modifying the power shared by the mains and BESS as well as the virtual voltages.

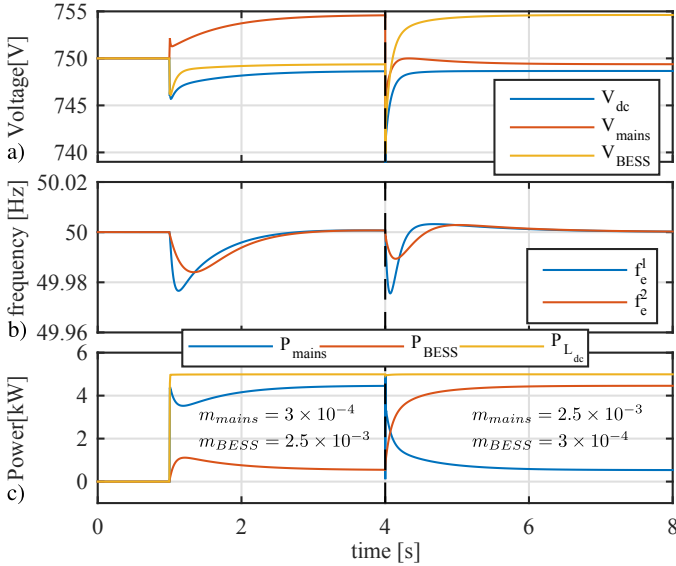

Fig. 11: Simulation results: P/V DC Droop operation. a) LVDC bus voltage and virtual mains and BESS voltages; b) NGs frequencies; c) power shared by the mains, BESS and DC load.

## VII. CONCLUSIONS

In this paper, a cooperative voltage and active power control is proposed for a hybrid AC/DC Microgrid with ESS, based on hybrid DC/AC virtual generators that allows the indirect collaboration between the regulation in the AC NGs and the LVDC bus, maintaining the grid quality in both the LVDC and the AC NGs. A control scheme based on DC virtual generators is proposed for the DC voltage regulation and power sharing between the mains and the central BESS that allows to adapt the participation of the mains and BESS in the transient and stationary power sharing for DC bus regulation and enable an automatic transition between *grid connected* and *islanding* modes. Meanwhile, the DC/AC virtual generators allow an automatic power sharing that couples the LVDC voltage and the NGs voltage and frequency, maintaining the power balance in the hybrid MG, not only reducing the stress in the central BESS and the dependence in the utility grid but also demonstrating the extended operation and improved transient response in the LVDC when the central BESS presents low inertia and power limitations. The theoretical discussion has been supported with simulations in MATLAB/Simulink.

## REFERENCES

- [1] J. M. Guerrero, "Editorial Special Issue on Power Electronics for Microgrids 2014;Part II," *IEEE Transactions on Power Electronics*, vol. 26, no. 3, pp. 659–663, March 2011.
- [2] J. Guerrero, P. C. Loh, T.-L. Lee, and M. Chandorkar, "Advanced Control Architectures for Intelligent Microgrids 2014;Part II: Power Quality, Energy Storage, and AC/DC Microgrids," *IEEE Transactions on Industrial Electronics*, vol. 60, no. 4, pp. 1263–1270, April 2013.
- [3] P. Wang, X. Liu, C. Jin, P. Loh, and F. Choo, "A hybrid AC/DC micro-grid architecture, operation and control," in *Power and Energy Society General Meeting, 2011 IEEE*, July 2011, pp. 1–8.
- [4] J. He, Y. W. Li, and F. Blaabjerg, "Flexible Microgrid Power Quality Enhancement Using Adaptive Hybrid Voltage and Current Controller," *Industrial Electronics, IEEE Transactions on*, vol. 61, no. 6, pp. 2784–2794, June 2014.
- [5] J. Zhang, D. Guo, F. Wang, Y. Zuo, and H. Zhang, "Control strategy of interlinking converter in hybrid AC/DC microgrid," in *Renewable Energy Research and Applications (ICRERA), 2013 International Conference on*, Oct 2013, pp. 97–102.
- [6] M. Ambia, A. Al-Durra, and S. Mueeen, "Centralized power control strategy for AC-DC hybrid micro-grid system using multi-converter scheme," in *IECON 2011 - 37th Annual Conference on IEEE Industrial Electronics Society*, Nov 2011, pp. 843–848.
- [7] Y.-R. Mohamed and E. El-Saadany, "Adaptive Decentralized Droop Controller to Preserve Power Sharing Stability of Paralleled Inverters in Distributed Generation Microgrids," *Power Electronics, IEEE Transactions on*, vol. 23, no. 6, pp. 2806–2816, Nov 2008.
- [8] M. Golsorkhi and D. Lu, "A Control Method for Inverter-Based Islanded Microgrids Based on V-I Droop Characteristics," *Power Delivery, IEEE Transactions on*, vol. 30, no. 3, pp. 1196–1204, June 2015.
- [9] P. Arbolea, C. Gonzalez-Moran, and M. Coto, "A hybrid central-distributed control applied to microgrids with droop characteristic based generators," in *Power Electronics and Motion Control Conference (EPE/PEMC), 2012 15th International*, Sept 2012, pp. LS7a.5–1–LS7a.5–8.
- [10] A. Navarro-Rodriguez, P. Garcia, R. Georgious, J. Garcia, and S. Saeed, "Observer-based transient frequency drift compensation in ac microgrids," *IEEE Transactions on Smart Grid*, vol. PP, no. 99, pp. 1–1, 2017.
- [11] A. Navarro-Rodriguez, P. Garcia, R. Georgious, and J. Garcia, "A communication-less solution for transient frequency drift compensation on weak microgrids using a D-statcom with an energy storage system," in *Energy Conversion Congress and Exposition (ECCE), 2015 IEEE*, Sept 2015, pp. 6904–6911.
- [12] I. Serban and C. Marinescu, "Control Strategy of Three-Phase Battery Energy Storage Systems for Frequency Support in Microgrids and with Uninterrupted Supply of Local Loads," *Power Electronics, IEEE Transactions on*, vol. 29, no. 9, pp. 5010–5020, Sept 2014.
- [13] M. Torres L., L. Lopes, L. Moran T., and J. Espinoza C., "Self-Tuning Virtual Synchronous Machine: A Control Strategy for Energy Storage Systems to Support Dynamic Frequency Control," *Energy Conversion, IEEE Transactions on*, vol. 29, no. 4, pp. 833–840, Dec 2014.
- [14] Y. Hirase, O. Noro, K. Sugimoto, K. Sakimoto, Y. Shindo, and T. Ise, "Effects of suppressing frequency fluctuations by parallel operation of virtual synchronous generator in microgrids," in *Energy Conversion Congress and Exposition (ECCE), 2015 IEEE*, Sept 2015, pp. 3694–3701.
- [15] L. Benadero, R. Cristiano, D. J. Pagano, and E. Ponce, "Nonlinear analysis of interconnected power converters: A case study," *IEEE Journal on Emerging and Selected Topics in Circuits and Systems*, vol. 5, no. 3, pp. 326–335, Sept 2015.
- [16] T. Vandoorn, B. Renders, L. Degroote, B. Meersman, and L. Vandevelde, "Active Load Control in Islanded Microgrids Based on the Grid Voltage," *Smart Grid, IEEE Transactions on*, vol. 2, no. 1, pp. 139–151, March 2011, use of Voltage-droop control.
- [17] A. Navarro-Rodriguez, P. Garcia, R. Georgious, and J. Garcia, "Adaptive active power sharing techniques for dc and ac voltage control in a hybrid dc/ac microgrid," in *2017 IEEE Energy Conversion Congress and Exposition (ECCE)*, Oct 2017, pp. 30–36.
- [18] D. Chen, Y. Xu, and A. Q. Huang, "Integration of dc microgrids as virtual synchronous machines into the ac grid," *IEEE Transactions on Industrial Electronics*, vol. 64, no. 9, pp. 7455–7466, Sept 2017.